

FIFTH FRAMEWORK PROGRAMME COMPETITIVE AND SUSTAINABLE GROWTH

DIRECTORATE GENERAL RESEARCH

CONTRACT NO. G3RD-CT-2000-00450



- The transfer times currently required for road to rail interchanges make it uneconomic to use for stage distances of under 500 kms.
- There are hundreds of thousands of standard non liftable semitrailers in Europe.
- There is strong resistance from the Road haulage industry to invest in the costly specialist trailers required by existing piggyback Lift On - Lift Off solutions.

## CargoSpeed

CargoSpeed is a rail/road intermodal system based on the Roll on-Roll off (RO-RO) concept used by the road/short sea RO-RO ferry services instead of the current Lift on-Lift off (LO-LO) practice, and is able to accommodate forecast traffic growth. It provides random-access at interchanges, with a planned capacity of a minimum of thirty simultaneously arriving and departing semitrailers, instead of the current one-by-one LO-LO system.

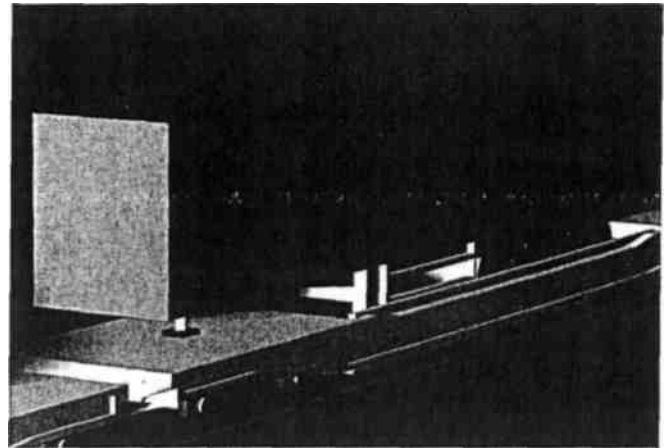
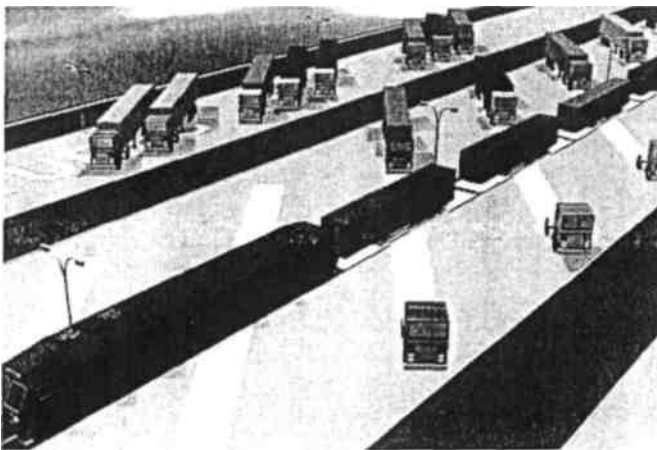

This also enables the accommodation of standard non-liftable semi-trailers, including high cube and aerodynamic semi-trailers. In this scenario, both the time intermodal trains spend in terminals and the idle time for the local transport, i.e., lorries, is reduced and minimised, optimising the operations.

All of these, together with the avoidance of unnecessary change from electric to diesel traction upon entering the terminal, and the fact that CargoSpeed will be operational within piggyback gauge, will reduce the economic break-even distance for intermodal freight movements by 50% from the current 500-600 kilometres to approximate 300 kilometres.



# The system

CargoSpeed is an innovative solution to the transfer of semi-trailers that will permit functioning rail freight to operate within a truly balanced and sustainable intermodal transport system. CargoSpeed is at the forefront of freight interchange technology and will demonstrate the enormous potential of intermodalism in the supply chain. The system is formed by terminal Pop-Up mechanisms and wagons equipped with a detachable Wellfloors.

The Pop-Up mechanism is the lifting and turning equipment of the CargoSpeed system. Its mechanical arrangements ensure fail-safe operation and fast repairs if necessary. The mechanism will be arranged for repair-by-replacement in minutes, with the aid of a small forklift truck.

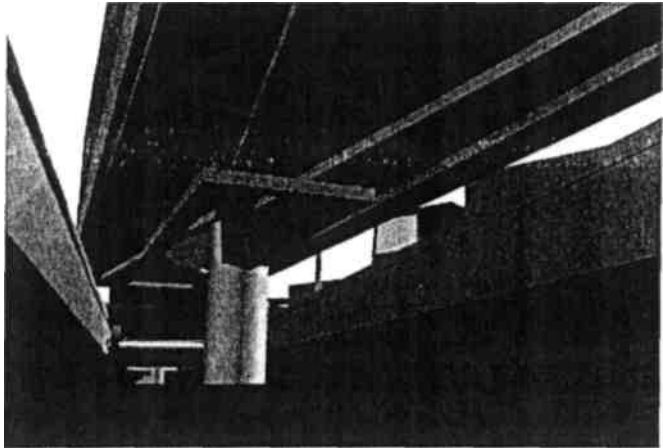
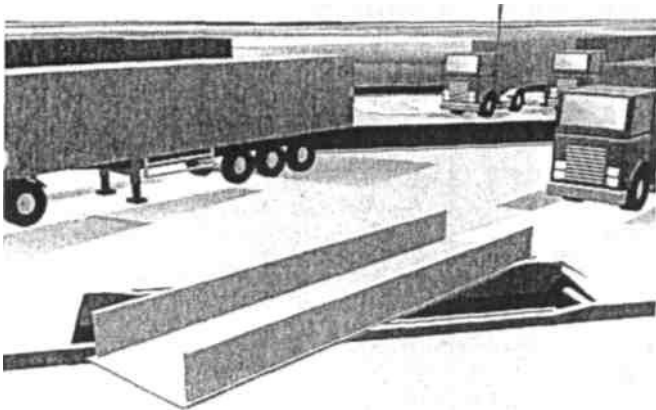

The purpose-designed wagon has, as a main feature, a detachable Wellfloor. The CargoSpeed roll on-roll off (Ro-Ro) wagon is equipped with a moveable Wellfloor on which the semi-trailer rests close to rail level. The moveable Wellfloor is a new concept and without precedent in railway engineering. The wagons are of comparatively simple construction and will be equipped with standard bogies with large diameter wheels.

The wagon design accommodates non-liftable standard semi-trailers having fixed, under-run, rear crashbars of up to 13.6m in length, and weighting up to 38.5 t.

The CargoSpeed system, as a road/rail interchange Ro-Ro system, has the capability to exchange standardised and non-standardised semi-trailers in a space-saving dedicated terminal. The exchange is achieved by the small Pop-Up mechanisms located centrally between the rails on the track at mid-lengths of the railway wagons. The arriving train, consisting of about thirty wagons, locates them over the Pop-Up mechanisms, whereupon the mechanisms rise to engage the Wellfloors by twistlocks. This is followed by elevation of the Wellfloor to pop-up the semi-trailer out of the wagon. Rotation about the vertical centre of the mechanism, aligns the arriving semi-trailer with the waiting tractor unit. The transfer can be carried out by the lorry drivers with dedicated equipment. One tractor unit reverses and hitches up and the arriving semi-trailer then proceeds directly out of the terminal. At the same time another truck drives across the Wellfloor and positions the departing semi-trailer prior to unhitching and exiting the terminal. For these operations, a specific traffic control system will be used.

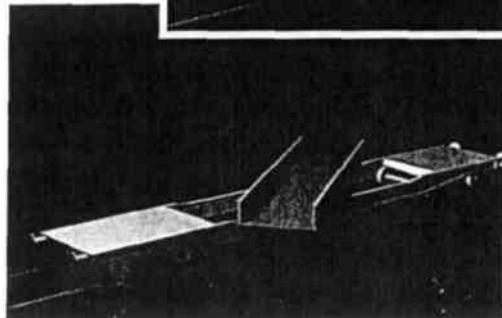
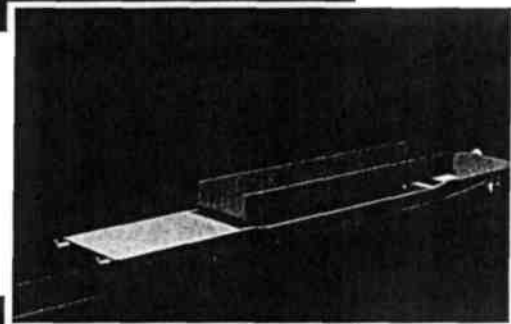
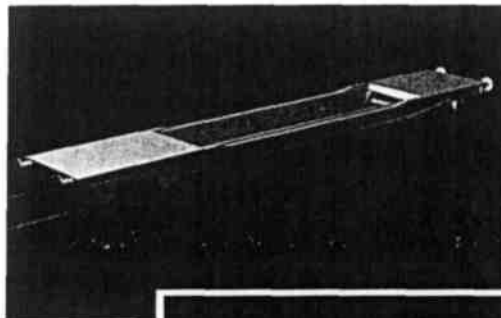

For more information on CargoSpeed, please visit our website [www.cargospeed.net](http://www.cargospeed.net)  
or contact the CargoSpeed coordinator,

Dr. Lars Stemmler: [stemmler.blg-consult@t-online.de](mailto:stemmler.blg-consult@t-online.de) Tel.: +49 421 398 3694 Fax: +49 421 398 3698



**BLG CONSULT GmbH**

RO.Box 286153,  
28361 Bremen  
Germany

Tel: +49 421 398 3694 Fax: +49 421 398 3698  
Homepage: <http://www.consult.blg.de>



**Advanced Railway Research Centre (ARRC)**

The Innovation Centre 217  
Portobello SI 4DP Sheffield  
UK

Tel. +44 114 2220151 Fax +44 114 2220155  
Homepage: [www.rrc.shef.ac.uk](http://www.rrc.shef.ac.uk)

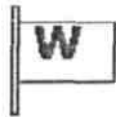

**Warbreck Engineering Ltd.**

12-16 Regent Rd.  
Liverpool L3 7DS  
UK

Tel. +44 151 236 5484 Fax  
+44 152 236 8585



**Costaferroviaria S.p.A.**

viale IV Novembre  
23845 Costamasnaga (Lecco)  
Italy

Tel. +39- 031.869411 Fax +39- 031.855330  
Homepage: [www.costaferroviaria.com](http://www.costaferroviaria.com)



CargoSpeed (Contract No: G3RD-CT-2000-00450) is partly funded by the European Commission in the 5th Framework Programme under the key action "Competitive and Sustainable Growth". CargoSpeed started in January 2001 and has a duration of two and a half years. **European Commission, DG Research, Mr. Joost De Bock**, Rue de Belliard 7, Brussels, Belgium, [Joost.De-Bock@cec.eu.int](mailto:Joost.De-Bock@cec.eu.int) Tel.: +32 2 2969089



## 4.2 System design

### 4.2.1 Overview

Main project output has been the design, construction and full-size testing of the CargoSpeed system which includes the terminal layout and operation, the design of a CargoSpeed wagon and transfer system. A testing site has been built and prototypes for the transfer system (pop-up mechanisms and a wellfloor) and the wagon constructed. The operation of the main part of the CargoSpeed system has been tested at a test site and on an animation platform. The marketability of the system has been proven. Reductions of at least to 30% of the total costs of the system in comparison to common techniques are expected.

CargoSpeed is an innovative solution to the transfer of semitrailers that will permit a functioning rail freight system to operate within a truly balanced and sustainable intermodal transport system. CargoSpeed is at the forefront of freight transfer technology and will demonstrate the enormous potential of freight intermodalism in the supply chain. The CargoSpeed road/rail interchange system is unique, applying technologies in an innovative way to improve the road/rail interchange. The CargoSpeed road/rail interchange RoRo system has an enormous potential to exchange standardised and non-standardised semitrailers in a space-saving dedicated terminal.

The exchange is achieved by small pop-up mechanisms located centrally between the rail lines at mid-lengths of the railway wagons. The arriving train of about 30 monowell wagons locates the wagons over the pop-up mechanisms (tolerance of plus/minus 35 centimetres), whereupon the mechanisms rise to engage the wellfloors by twistlocks (container handling type but opposite way up) followed by elevation of the wellfloor to pop-up the semitrailer out of the wagon.

Rotation about the vertical centre of the mechanism, either 36 degrees anticlockwise or 144 degrees clockwise dependent from which direction the train has entered the terminal, aligns the arriving semitrailer with the consignee's waiting truck. The transfer is carried out by the consignee's and consignor's truck drivers or extra equipment. The consignee's truck reverses and hitches up the arriving semitrailer and proceeds directly out of the terminal, whilst the consignor's truck drives across the wellfloor and positions the departing

semitrailer prior to unhitching and exiting the terminal. A specific traffic control system is necessary.

The figure below illustrates the CargoSpeed process of loading and unloading of a semitrailer.

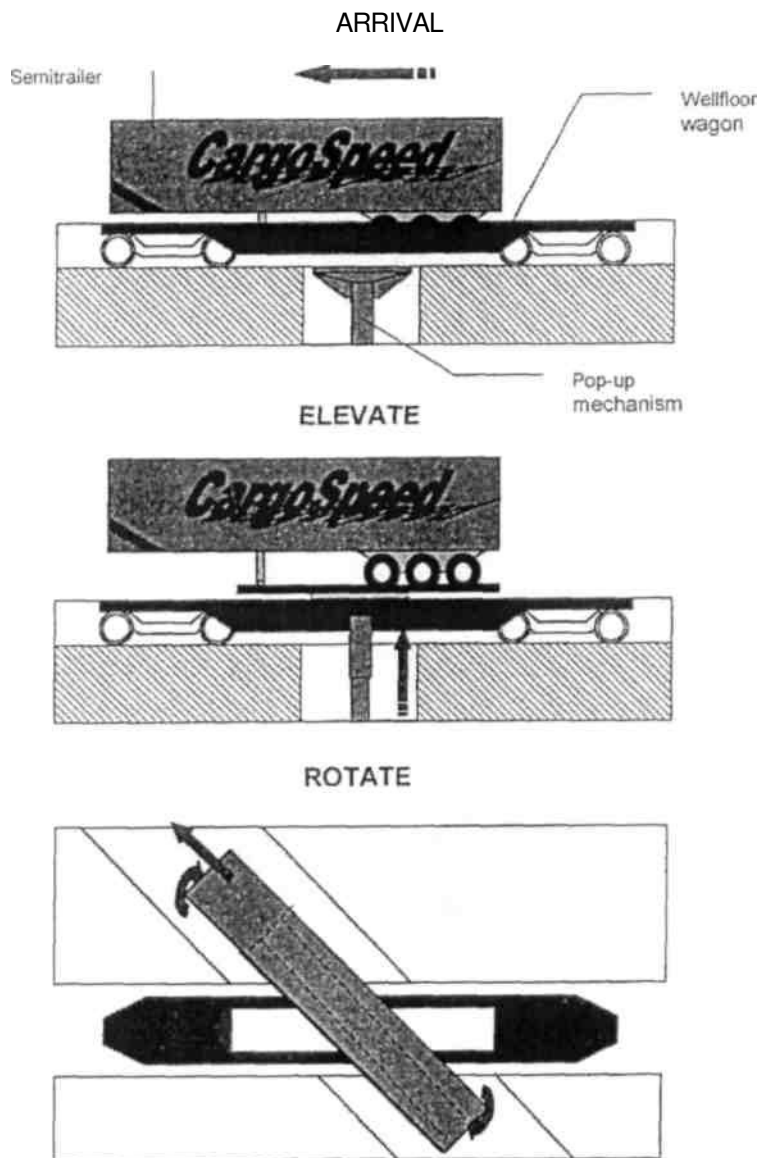

**Figure: 1: The CargoSpeed loading and unloading process**

The common technique today is the LoLo piggyback system whereby special nonstandard liftable road semitrailers are grapple lifted into "pocket" type rail wagons. Considering the LoLo of special non-standard liftable semitrailers onto piggyback "pocket" wagons has been operating on European rail routes for many years, the total movements

by UIRR companies amounted to 170,000 liftable non-standard semitrailers in 15 countries in 1998. This equates to just 470 LoLo trailer movements daily in West and Central Europe including Scandinavia - the sort of total that RoRo ferries in the same region achieve in matters of minutes.

#### **4.2.2 Pop-up units**

Each unit is rated for 45 tonnes at 1.75 metres off-centre, and the mechanical arrangements ensure fail-safe operation and fast repairs if necessary. The mechanisms are arranged for repair-by-replacement in minutes with the aid of a small forklift truck. The quick-change capability also allows preventive maintenance.

Of several concepts discussed, the most promising is a vertical tubular steel structure, comprised of a standing fixed section and a sliding/turning upper section. The upper tubular section is fitted with a rectangular top frame in the horizontal plane, equipped with upwards-pointing twistlocks (of container-handling type) positioned at the four corners.

The lifting action of the upper section is achieved by a centrally located heavy-duty threaded rod turned by a high-torque slow speed hydraulic motor mounted within the top frame. The threaded rod turns in a fixed nut /safety-nut assembly located centrally within the top of the standing lower tubular section, thereby giving elevating motion to the upper section. To prevent any tendency for the upper section to rotate during vertical motions, a small anti-rotation lock maintains alignment.

From below rail level, the top frame elevates to engage the twistlocks into elongated slots in the underside of the wagon wellfloor, which slots are aligned with the railtrack. The four twistlocks are turned from alignment with the railtrack to alignment across the railtrack, thereby securely attaching the transfer mechanism to the wellfloor.

Elevation of the wellfloor with semitrailer on top continues to maximum height, whereupon the anti-rotation lock is disengaged and simultaneously duplicate band brakes engage with a brake drum located on the lower end of the threaded rod below the nut / safety-nut assembly. With the threaded rod securely held, small rotation of the high-torque hydraulic motor rotates the wellfloor either 36 degrees anti-clockwise, or 144 degrees clockwise dependent from which direction the train has entered the terminal, to align the wellfloor with the consignee's waiting truck and consignor's truck/semitrailer. Release of the band brakes, re-engagement of the anti-rotation lock, and reverse rotation of the threaded rod lowers the wellfloor to rest on platforms (or ground if the railtrack is laid in a trench).

### 4.2.3 Wagon and well-floor

Similar to a LoLo 'pocket' wagon but rather longer, the CargoSpeed RoRo wagon is equipped with a moveable wellfloor on which the semitrailer rests close to rail level. The wagons are of comparatively simple construction and are equipped with standard bogies having large diameter wheels. Sufficiently narrow to move freely through European networks, the wagon design accommodates non-liftable standard semitrailers having fixed under-run rear crashbars of up to 13.6 metres in length, and weighing up to 38.5 tonnes.

The most important feature of the wellfloor is the central box-structure spine which transmits both self-weight and semitrailer loading to the crossframe bulkheads at either end of the wagon well during rail transits. Cantilevered from either side of the box-structure are the structures which support the semitrailer road and jockey wheels during rail transits, and provide the roadways over which the truck/semitrailers travel during terminal exchanges. These structures are preferably of double-skin construction for strength and weight saving, and require great care in design to avoid complications in manufacturing assembly.

Along approximately 40% of the lengths of the wellfloor outer edges are continuously hinged sideplates. The sideplates are level during semitrailer exchanges, and hinge upwards upon contact with the wagon sideframes as the wellfloor descends into the wagon - bearing hard against the semitrailer road wheels. The transverse location and transverse securing of the semitrailer will be achieved automatically during descent into the wagon. The continuous (piano-type) hinges will need much care in design since side loads from inaccurately positioned semitrailers could be severe.

The ends of the wellfloor are equipped with pairs of hinged road wheel bridging plates to smooth the truck/semitrailer transfers onto, and from, the wellfloor. These bridging plates hinge up automatically upon contact with the well end crossframe bulkheads, and stow near-vertical during rail transits. Centrally located on the underside of the box-structure are four slots each of approximately 85 centimetres length. These slots are aligned to allow freedom of entry of the upwards-pointing twistlocks of the pop-up transfer mechanism, allowing tolerance of wagon position.



The moveable wellfloor is a new concept and without precedent in railway engineering. It is the intention that the wellfloor should be standardised and completely interchangeable between CargoSpeed wagons, especially for gauge change situations between France/Spain and between Central/Eastern Europe. Similarly, the narrow gap between United Kingdom platforms requires a heavier wagon construction than is necessary for mainland Europe. In these situations it is envisaged that frontier terminals having "high-rise" pop-up transfer mechanisms would permit very rapid changes of complete CargoSpeed trainloads from narrow gauge to wide gauge, or from wide wagons to narrow wagons.

A detailed analysis of the CargoSpeed wagon design requirements has been carried out. During this process, the gauge, structural and braking requirements have been considered, leading to the following conclusions:

| <b>Feature</b>                   | <b>Tiphook wagon*</b> | <b>CargoSpeed wagon**</b>                        |
|----------------------------------|-----------------------|--|
| Total length                     | 16.2 m                | 18.2 m   |
| Distance between the bogie axles | 11 m                  | 13.5 m   |
| Tare                             | 28 tonnes             | < 24 tonnes<br>(including wellfloor)             |
| Pay load                         | 37 tonnes             | < 38.5 tonnes (max. total weight of semitrailer) |
| Type of bogies                   | Y27                   | Y27  |

\*) The design of this wagon-type is comparable to a CargoSpeed wagon, a wagon of this type to be re-worked to serve as a CargoSpeed prototype.

\*\*\*) Figures will apply to CargoSpeed-wagon design, not re-worked prototype.

## **Table 2: Wagon design comparison**

These requirements and specifications of the CargoSpeed wagon have been compared to the characteristics of an existing piggyback wagon, the Tiphook wagon. A Tiphook wagon was purchased to be re-worked within the scope of WP 4. In order to complete the CargoSpeed prototype and to demonstrate this technology the existing wagon was modified.

Several versions of the wellfloor design have been considered, using the wellfloor named Mark VIII as the basis for the analysis. After the evaluation of the structural and geometrical properties of the wellfloor Mark VIII design, it was considered (too) heavy for

application in continental Europe as it was designed for UK requirements. Therefore, an alternative design was developed by Costa to be built in WP 4. This proposed design is easier to adapt and integrate into the CargoSpeed wagon.

|  | <b>Costa Design</b>  | <b>Mark VIII*</b> | <b>Deviations</b>         |
|--|----------------------|-------------------|---------------------------|
| Area of Cross-section (mm <sup>2</sup> ) | 40600                | 72300             | Obtaining a 44% reduction |
| Weight (tonnes)                          | 4                    | 5.6               | Obtaining a 30% reduction |
| Moment of inertia (mm <sup>4</sup> )     | $J_x=3,5 \cdot 10^9$ | $0.7 \cdot 10^9$  | 420% increase             |
|  | $J_y=36 \cdot 10^9$  | $29 \cdot 10^9$   | 24% increase              |
| Length (m)                               | 9.850                |                   | 9.850                     |

\*) Design discarded.

**Table 3: Comparison of evaluated wellfloor designs**

The requirements and specifications for the wellfloor include the position of the slots underneath in order for the wellfloor being liftable by the Pop-Up Mechanism.

#### 4.2.4 Terminal

A CargoSpeed terminal is characterised by a single rail track way equipped with a series of pop-up mechanisms located between the rail tracks at spacing equal to the length of a wagon. Contrary to conventional combined transport - as no crane activities are necessary - hence, this track can be equipped with catenary so that there is no need to change from electric to diesel traction when drawing the train into the terminal. Alongside the track there are the marshalling and dispatch areas for incoming and outgoing trucks respectively. The terminal is designed based on a one-way traffic management system. Incoming trucks are received on the marshalling area for pre-stowage prior to train arrival. Outgoing semitrailers are to be taken over by the tractor units within the dispatch area. In figure 2 the position of the pop-up units is indicated by the circles.

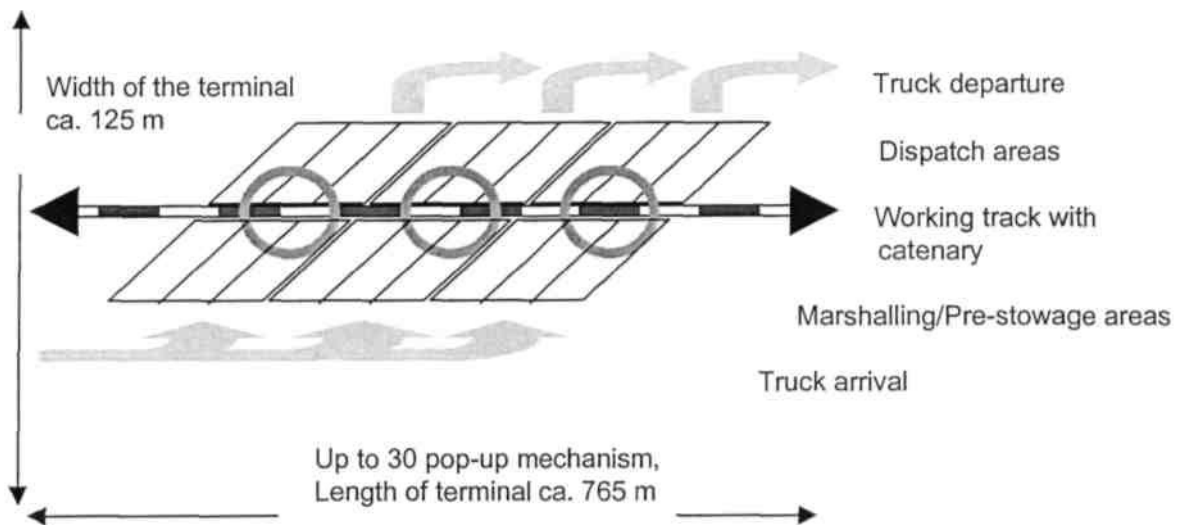

**Figure 2: Principal layout of CargoSpeed terminal**

Although the terminal features just a single working track, the terminal is designed for an annual capacity of 200,000 trailer handlings. This is achieved by train handling times as short as 30 minutes<sup>1</sup> compared to 2.5 hours employing a conventional lift-on/lift-off system (figure 3).

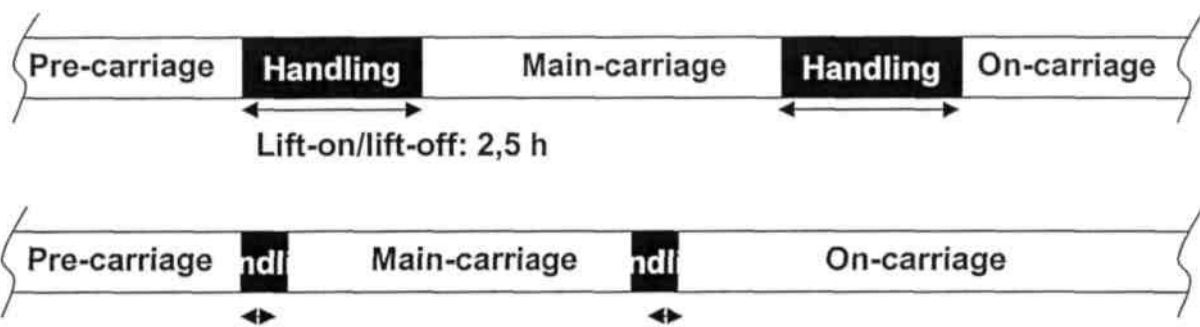

**CargoSpeed: 0,5 h**

**3: Comparison of handling times**

Valuable time is saved as electric locomotives can go right into the terminal, which avoid lengthy engine exchanges from electric to diesel traction and vice versa. Furthermore, coupling and decoupling of the semitrailers is just as a routine task for the drivers as

---

<sup>1</sup> Minimum train turn-around time for terminal handling only.

driving itself which further saves time on handling. The pop-up units can almost be operated at the same time making a parallel transfer of up to 30 semitrailers a realistic perspective.

The terminal is also designed to exploit the random-access capability of CargoSpeed. Any wagon can be accessed directly at any terminal. This is a major advantage compared to the Rolling Road and adds some flexibility to the system. With random-access capability bus-stop like operations can be considered in addition to pure point-to-point services (see below chapter 3: Operations concepts).

An arriving CargoSpeed train locates the wagons over the mechanisms within a specific tolerance which has to be calculated in the same manner that Japanese "Shinkansen" trains stop precisely in stations. Then, the already described processes of lifting and turning of the pop-up units follow.

Alignment of the arriving semitrailers with the consignees' waiting trucks is now complete and, after removal of the arriving semitrailers, the departing truck/semitrailers drive across the wellfloors upon which the departing semitrailers are accurately deposited by the consignors' trucks. Wagon suspension problems during semitrailer transfers are avoided by the wellfloors being completely out of the wagon. This will be a unique feature of CargoSpeed and contrasts with the elaborate rail wagon suspension levelling necessary for road-to-rail transfers on Eurotunnel's 'Le Shuttle' services, and on all other horizontal transfer systems.

### **4.3 Animation**

The animation constitutes a deliverable within work package 3 (for a list of deliverable see chapter 5). The animation is a virtual-reality video clip of c. 7 minutes in length that illustrates how the system components work together. The complete and geometrically accurate 3D representation of the system components enables the potential client to view any facet of the system at any point in time and space. It runs on almost every Windows-PC and is delivered on a CD-ROM (a copy of the animation is attached to this report). The animation has been given away together with the brochure (see below) on the various interview and presentation occasions.

#### 11.6.4 Press coverage (selection)

BLG

##### **Innovative KV-Umschlagtechnik**

Eine neue Umschlagtechnik für den Kombinierten Verkehr (KV) hat kürzlich die BLG Consult GmbH, Bremen, zusammen mit Newrail der Universität New-castle und Warbreck Engineering Services, Liverpool, vorgestellt. Das Forschungsprojekt CargoSpeed (Cargo Rail Road interchange at Speed) hat in dem Prototypen die Vorteile des Ro/Ro-Umschlags für die Schiene nutzbar gemacht. Das horizontale Umschlagsystem für Sattelanhänger im KV besteht aus fest installierten Hubstempeln und Waggons mit beweglichen Schalböden zur Aufnahme der Trailer. Die zwischen den Gleisen installierten Stempel heben die Schalböden an, drehen sie samt Ladung aus der Zuglängsrichtung und senken sie ab, so dass die

Trailer auf eigener Achse vom Waggon rollen können. Der Ladevorgang läuft umgekehrt. Während der Fahrt ruht der Schalboden in der Waggontasche. Die Sattelaufleger werden am Königsbolzen gesichert. Mit diesem System können bis zu 30 Waggons gleichzeitig be- oder entladen werden. Weitere Informationen unter [www.cargospeed.net](http://www.cargospeed.net)

## CargoSpeed demonstrated

A PROTOTYPE of the CargoSpeed **inter-modal** wagon loading system was unveiled near Chesterfield on July 29.

Being developed by BLG Consult, Warbreck Engineering and Newrail in collaboration with Cholerton Ltd, CargoSpeed is an attempt to use roll-on roll-off ferry concepts to reduce the time spent at rail terminals and lower the distance over which intermodal transport is viable.

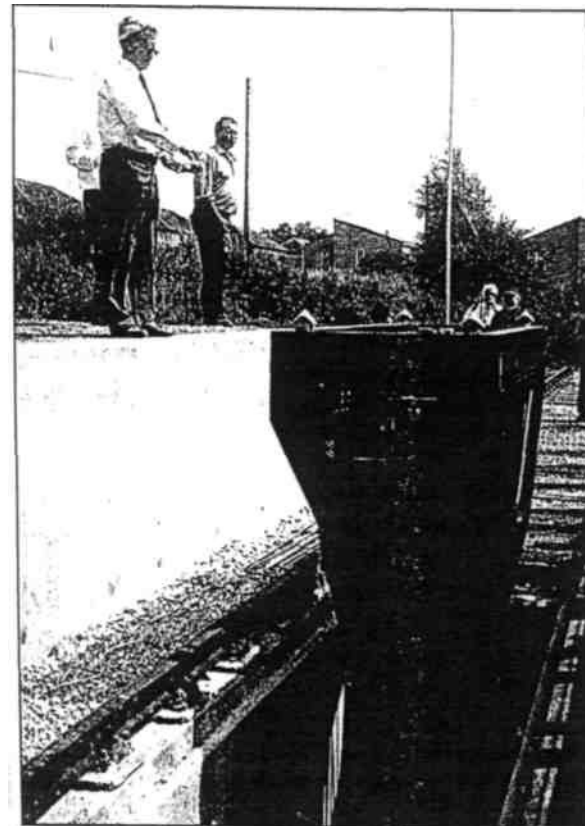

A train of well wagons with removable decks arrives at a terminal, and stops between two raised platforms. A hydraulic 'pop-up' column (below left) rises from a pit between the rails under each wagon, and twistlocks engage with the deck. The pop-up raises the floor above the wagon, and rotates it 36° clockwise to form a bridge between the platforms (below centre). A lorry is driven onto the bridge, the trailer unhooked, and the tractor driven off (right). The wagon deck swings back, and is lowered into place.

On arrival at the destination the deck is again raised, and the trailer hauled off one side of the wagon to be replaced by another waiting on the opposite platform. If the train arrives from the other direction, the deck can be rotated 144° anti-clockwise.

CargoSpeed can accommodate a standard 13.6 m long, 4 m corner-height semi-trailer

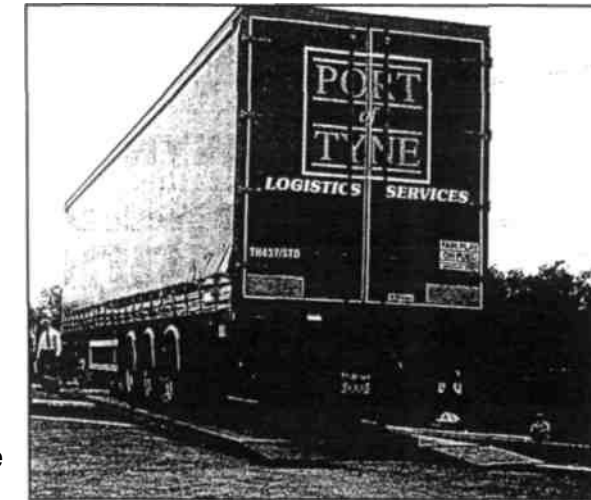
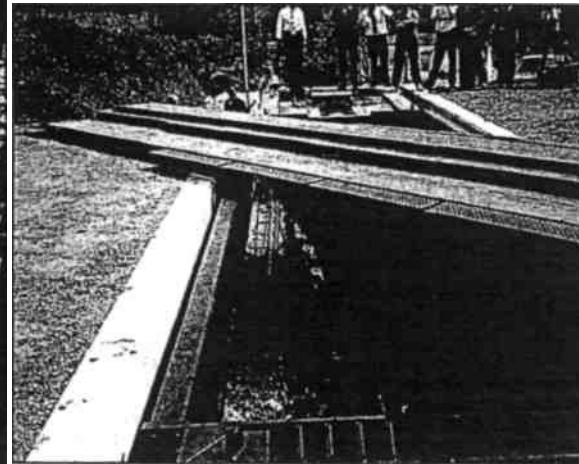

within the B+ loading gauge, and the ability to use non-liftable trailers offers a potential 200 kg increase in lorry payload. Each wagon can be loaded independently, offering the possibility of 'bus stop' services, with lorries being picked up and set down during 20 min stops at yards along a given route.

Inventor Jack Brown estimates that at around €35 000 each, pop-ups for a train of 30 wagons would cost around the same as a travelling gantry crane. The tolerances allow the wagon to be positioned up to 0.35 m either side of the pop-up mid-position.

The first phase of the project was funded by the European Commission, but further funding is now being sought to develop CargoSpeed in co-operation with the rail and logistics industries; once teething problems are solved, it is hoped to demonstrate a fully-working prototype in October.

BLG Consult, Germany  
Reader Enquiry Number: 200

## A step forward for Cargospeed?

A full-scale demonstration of the Cargospeed ro-ro,rail/road transfer technique for non-liftable, semi-trailers took place last month at the Barrow Hill rail test centre in Chesterfield, England. The centre is run by Newrail, part of Newcastle University. Newrail took over the role which the ARRC at Sheffield University previously had in this EU-backed project.

As is well-known, Cargospeed is based on the "shwople" concept first developed by Jack Brown of Cholerton Ltd in the early 1990s. Officially Cholerton is not part of the EU project because of the Isle of Man's status in the EU. However, Brown is the "father" of the system and holds various patents. He believes that Cargospeed will be able to compete with trucking on distances as short as 250-300 kms and is looking to license interested rail freight operators.

### Extended

The €1.8 mill project, co-financed by the European Commission (DG Research) and the industry

### Will Cargospeed blaze a trail for standard road trailers by rail?

partners, started in January 2001. Its original 30 month deadline was, as previously reported, extended after a number of setbacks, most notably the bankruptcy of the designated wagon builder, Costaferrroviaria.

The demonstration was made with an old Tiphook piggyback wagon fitted with a new Cargospeed well floor. This was lifted by the Cargospeed pop-up mechanism ("probably mark 18," remarked Brown) built by project member Warbreck Engineering.

A purpose-built Cargospeed wagon would be of relatively simple construction, with standard bogies and large diameter wheels. The well floor, says Brown, is really a kind of "pallet" which is raised, turned and lowered by the pop-up located in the ground. In essence, the wagon is "passive."

This is a big difference with the heavier, powered Modalohr

wagon. But by the same token, a Modalohr terminal needs only the raised platforms; nothing needs to be installed underneath the rail.

Another intended feature of a purpose-built Cargospeed well wagon is an automatic kingpin capture/release device which, as previously reported, would use a Russian, elastomer-based, shock absorption system. The automatic (de)coupling is an aid to fast turnaround as well as securement. The well floor prevents lateral sway and its low height allows for 4m high trailers on UIC B.

### Hit a hitch

The demonstration was not a complete success. The pop-up appeared to work well but there was a problem with the well floor midway through the cycle and it got stuck. But teething problems are to be expected when dealing with any pre-production prototype and in any case there was hardly any time for trouble-shooting.

The timing and the public nature of the test were mandated by European Commission (ECOM) rules. In the years leading up to the project, Brown received encouragement from Joost de Bock at DG Research. Without ECOM's backing, the idea would probably still only exist as a model.

The turn-out at Chesterfield was disappointing although SNCF Fret was represented, indicating perhaps that it has an "open mind" about alternatives to Modalohr.

Packet Company and local haulier Trade Partners, using chalk marks to represent the wagons.

An individual trailer (un)loading cycle is quicker with a terminal tractor than with a road tractor as there is no need to wind the jockey wheels up and down. However, there would normally be only 6-10 terminal tractors, but one would expect the full complement of consignors' and consignees' road tractors to be at their slots when the train pulls in.

### A million a year!

In any event, if the figures are realistic, they equate to 0.8-1 mill trailer arrivals and departures/year, based on 24/7 operation. This is just the sort of scale the Dutch are looking for, in what would be a massive coup for intermodal rail.

As previously reported a Dutch team is looking to transfer UK-Germany trailers shipped over Rotterdam from road to the Betuwe line (see *WorldCargo Nat's*, November 2003, pp25-26). The case is potentially perfect for Cargospeed. Mass flow is provided by the ro-ro ships and all the operators are already well-versed in unaccompanied transport.

As with ships ro-ro rail is much faster than lo-lo, says Brown. Ro-ro ships are 2.5 times more expensive than lo-lo ships of the same capacity, but they outcompete lo-lo in shortsea trades because of mass flow and fast turnaround. Ships, trains and trucks can only make money when they are on the move.

A Betuwe-scale terminal could apparently require as

for Modalohr, but the Cargospeed team was not able to obtain figures from Lohr to make comparisons. Certain other characteristics are shared by Cargospeed and Modalohr. A key one is random access, which allows for the possibility of "bus stop" services, on long distance trains or, more feasibly, on short train sets (viz: 5-slot FMUs) serving a region or a conurbation. For bus stop services to work, the timetables have to be reliable and IT is essential, as there has to be complete transparency about slot availability.

In addition, as Modalohr and Cargospeed are horizontal transfer systems, all work is carried out under the catenaries. There is no need to switch to diesel power in the terminal, saving money and time - at least 60 mins per train.

Both systems also cater for absolutely standard road trailers. The constituency for trailers is fairly weak in rail intermodal circles, because the extra tare is bad for train economics. But this misses the point that most goods are carried in trailers. If intermodal concentrates on containers, swap bodies and a few piggyback trailers, it is admitting defeat.

The Dutch, who need to find freight for the planned Betuwe line, have grasped this with the bold plan to transfer UK-Germany trailers to rail *en masse*.

Unlike Cargospeed, Modalohr can cater for accompanied as well as unaccompanied trailers but naturally is most efficient in latter mode. A unique feature of Cargospeed is that the well floor can be swung either way, so it does not matter which way the train comes in.

### Quo vadis?

So where to now? Many good! PI 1

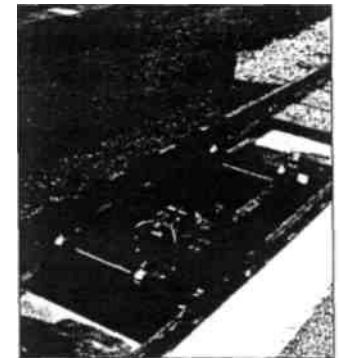

Pop-up in stored position

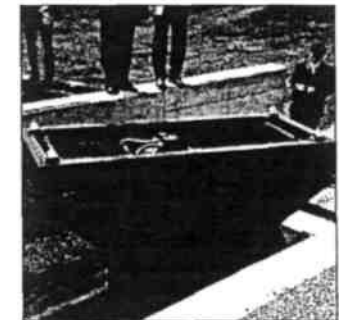

Pop-up being raised and turned. The twistlocks will connect with the underside of the wagon well floor with  $\pm 350$ mm tolerance of the train stop position. The pop-up is "failsafe" (screw jack elevation) and is fitted with a single, slow speed hydraulic motor. A force of 100 psi lifts the well floor with a 38 tonne trailer the required 120-130mm above the height of the platform alongside, and a force of up to 350 psi can rotate it in worst case conditions (crosswinds, ex-centric loading). A "down" pop-up can be lifted clear of the retaining pins at the bottom of the ground socket for repair

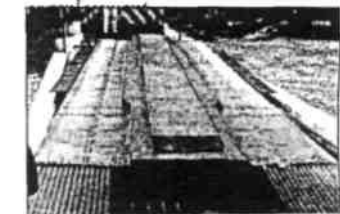

...ian. u INCWldll, says another demo is planned for October. By en, the bugs should have been ironed out and other interested parties are keen to attend.

## Turnaround speed

The *modus operandi* of Cargospeed has been reported before and does not need repetition here, but several key points perhaps need reiterating. First, speed of turnaround: a minimum of two and possibly three 30-trailer (700m long) trains per hour, according to Brown.

This calculation is based on semi-trailer hitch-up and drop time trials he carried out last December at the Douglas ferry terminal with the Isle of man Steam

uaiMj, puis .I ctiupic ui spares lu provide redundancy. But no-body yet know the econ .ics. Estimates for pop-ups in series production vary between €35,000 and €50,000. That could amount to €2 mill, about the same as a lo-lo terminal with an RMG which can cater for containers and swap bodies as well as liftable trailers.

The risk can be mitigated by installing a smaller number of pop-ups, say 10, which would also save on platform length. The train would then move up the track in intervals of 10. Of course, train turnaround time would be slower.

Fast turnaround is also claimed

iiiiisi liccausc no investor coulo IK\* found to take them forward. To some extent the onus must be on BLG Consult, as project leader, to leverage its connections as a part of the BLG Logistics group.

But there is a reluctance to invest m European internlodal,even as road congestion worsens and the case for modal shift gets stronger. A major concern today is the future for *RoLa* services. Okombi, for example, has again expressed concern that *RoLa* cannot compete with transit trucking in the long run. But market organisation is a key issue here. East European owner/operators are not going to switch to unaccompanied. A system such as Cargospeed requires forwarders or fleet operators with scale, commanding substantial cargo flows. Speaking at Chesterfield, EIA secretary general Klaus Ebeling said there is potential for systems such as Cargospeed in the TENs, but only if they are recognised *prima facie* as intermodal corridors and not just trucking routes. There is a particular problem of perception in Eastern Europe, where rail tends to be associated with the old, discredited command economy.

Connected with the intermodal TEN concept is the new EU freight integrators study, aimed at proposing new uniform intermodal liability rules and a single intermodal transport document, to provide seamlessness.

Unfortunately, the European intermodal industry is very disunited. The European Rail Freight Association (EFA), representing the "new breed" of private operators, is calling for the Betuwe project to be halted, on the ground that the signalling and power systems require very expensive locos which only Railion can afford! So, EFA is behaving just the same as the old "monopolists" are said to by the "newcomers" - we can't have it and nor will you! For crying out loud!!!

u



The wagon is in position. Tile pop-up has raised the well floor and is starting to rotate it 36 degrees clockwise



Inventor Jack Brown and the driver from Port of Tyne Logistics get ready...

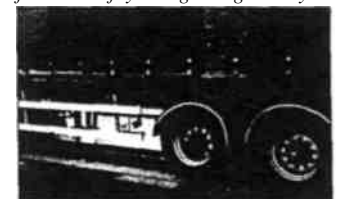

...on she goes

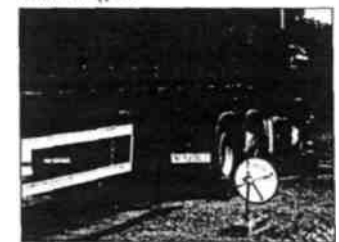

The driver uses the convex mirror to line up the jockey ufacets on the right spot

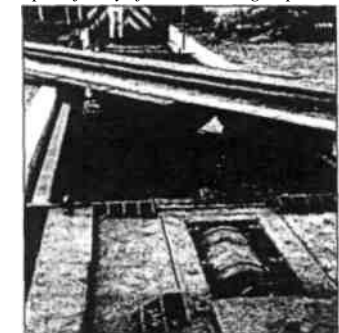

Uniquely, Cargospeed can he rotated 144 deg counter-clockwise, so the train can arrive from the opposite direction

if it has to do with containers  
you should probably talk to us

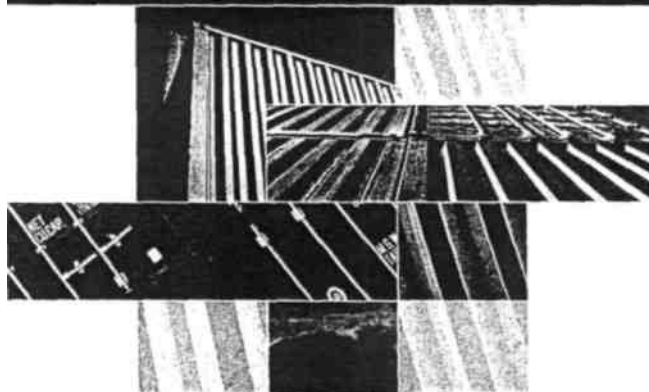

**CONTAINER ◀ ▶ LEASING A/S**  
 www.containerleasing.com  
 Denmark United Kingdom  
 Phone: +45 33 15 15 30 Phone: +44 1291 626388  
 Fax: +45 33 15 05 20 Fax: +44 1291 626886  
 cl@containerleasing.com containerleaseuk@easynet.co.uk



# Kombiumschlag mit CargoSpeed

Das neue Umschlagsystem CargoSpeed soll die wirtschaftliche Minimaldistanz im Unbegleiteten Kombinierten Verkehr auf 300 km senken.

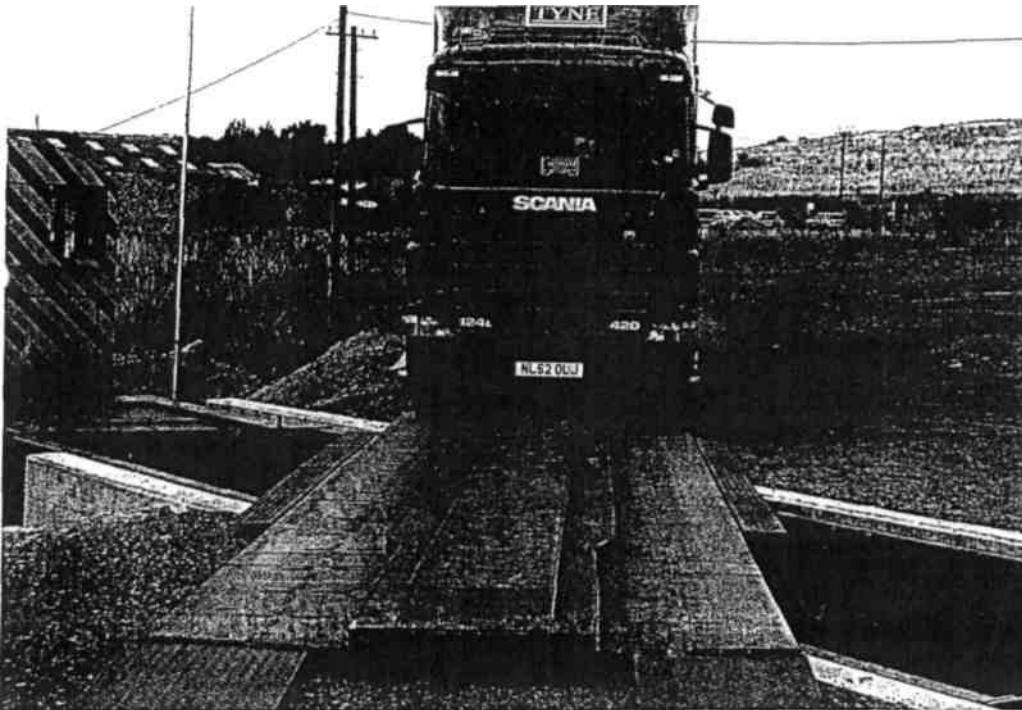

Eine Zugmaschine zieht einen Auflieger auf den Hubstempel. Danach wird dieser angehoben, in Zuglängsrichtung gedreht und abgesenkt, bis der Lkw auf dem Waggon ruht.

Foto: CargoSpeed/BLG

Ein Prototyp der neuen CargoSpeed-Umschlagtechnik wurde jüngst in England vorgestellt. CargoSpeed (Cargo Rail Road Interchange at Speed) ist eine innovative horizontale Umschlagtechnik für Sattelanhänger im Kombinierten Verkehr (KV). Da-

bei werden die Vorteile des RoRo-Umschlags für die Schiene nutzbar gemacht.

## Technisch und...

Die Präsentation zeigte die technische Machbarkeit des schnellen horizontalen Umschlags von Standard-Auflie-

gern. Die patentierte Technik besteht aus fest installierten Hebebühnen und Waggons mit beweglichen Schalböden zur Aufnahme der Trailer. Die zwischen den Gleisen installierten Stempel heben die Schalböden an und drehen sie samt Ladung aus der

Zuglängsrichtung und senken sie ab, so dass die Trailer auf eigener Achse vom Waggon rollen können. Der Ladevorgang verläuft entsprechend umgekehrt. Während der Fahrt ruht der Schalboden in der Waggontasche. Die Sattelaufleger werden am Kingpin gesichert. Es können bis zu 30 Waggons gleichzeitig und schnell be- oder entladen werden.

## ... wirtschaftlich möglich

In zahlreichen Studien wurde auch die Wirtschaftlichkeit des Systems nachgewiesen. Anlass für das Projekt waren die zunehmenden Staus von täglich bis zu 5000 km Länge auf Europas Autobahnen, die innovative Eisenbahntechnologien immer attraktiver werden lassen. Wirtschaftlich orientiert sich CargoSpeed am Vergleich zum durchgehen den Lkw-Verkehr. Ziel ist die Halbierung der Break-Even-Distanz im KV von derzeit etwa 600 km auf 300 km.

Geleitet wird das im Rahmen des 5. Forschungsprogramms der EU geförderte Projekt von der BLG Consult GmbH, Bremen (Deutschland). Partner sind unter anderen Newrail (Universität Newcastle) und Warbreck Engineering Services, Liverpool (beide Grossbritannien),

hol

[www.blg.de](http://www.blg.de)

[www.cargospeed.net](http://www.cargospeed.net)

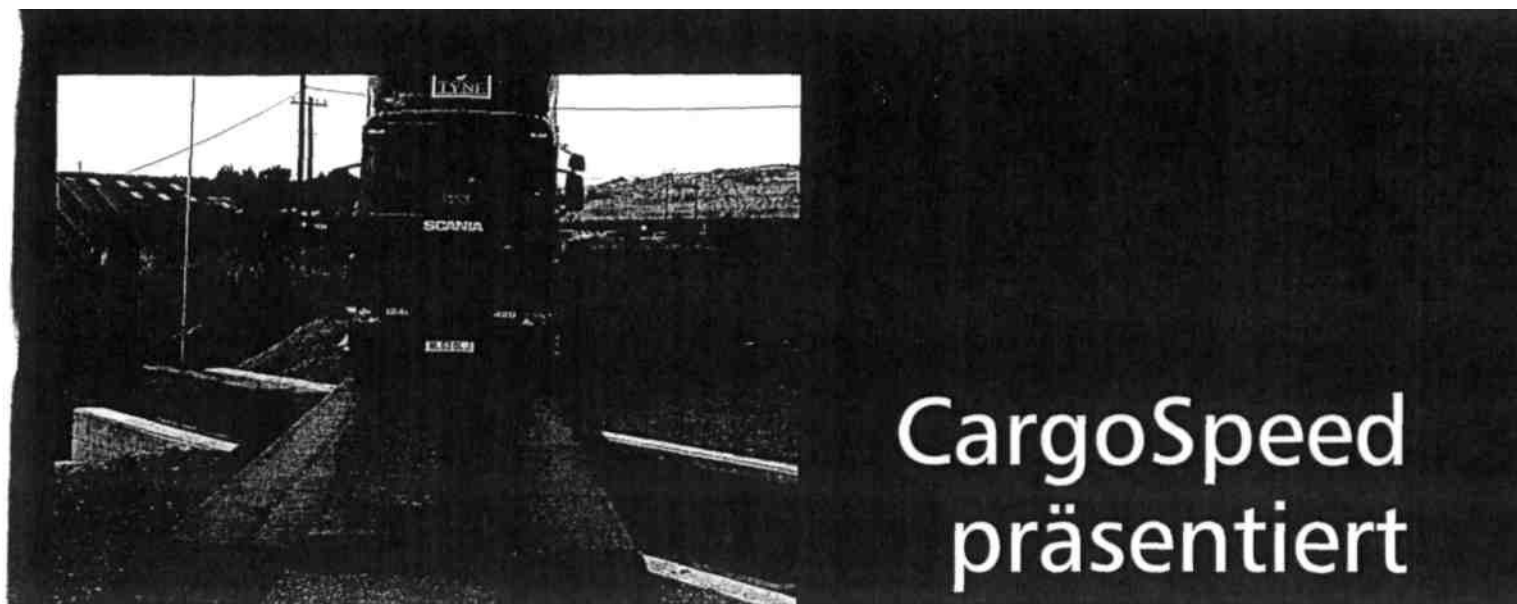

## CargoSpeed präsentiert

Prototyp

**D**er Prototyp CargoSpeed wurde im August in England vorgestellt. Der Name CargoSpeed steht für eine neue Umschlagtechnik im Kombinierten Ladungsverkehr (KLV). Dabei rollen die Fahrzeuge erstmals direkt auf Bahnwaggons und müssen nicht mehr mit Krananlagen verladen werden.

Das patentierte Verfahren ist schnell und preiswert. Das Prinzip: Waggons mit drehbaren Böden nehmen die Trailer auf, so dass diese auf eigener Achse be- und entladen werden können. Bis zu 30 Waggons lassen sich auf diese Weise gleichzeitig bearbeiten. Das von der EU geförderte Projekt wird von BLG CON-

SULT koordiniert. Projektpartner sind die Universität Newcastle und Warbreck Engineering Services, Liverpool.

[www.cargospeed.net](http://www.cargospeed.net)