



OMNI

IST- 1999 - 11250

*Open Model For Network-wide Heterogeneous
Intersection-based Transport Management*

FINAL REPORT

Covering period 01.03.2000 – 28.02.2003

Report Version: *v1.0*

Report Preparation Date: *30.04.2003*

Classification: *PUBLIC*

Contract Start Date: *01.03.2000*

Duration: *36 months*

Project Co-ordinator: *Antonio Marqués (ETRA Investigación y Desarrollo, S.A)*

Partners:

ETRA Investigación y Desarrollo,

S.A Project Automation, S.p.A

CITILOG

INRETS

Transport Research Group. University of Southampton

Polish Association Image Processing

Technical University of Crete

Mizar Automation S.p.A

Ayuntamiento de Alicante

Chania Municipality

Comune di Milano



**Project funded by the European Community
under the “Information Society Technology”
Programme (1998-2002)**

Financial/Administrative co-ordinator

Name: Antonio Marqués

Address: Tres Forques, 147

Phone Numbers: +34963134082

Fax Numbers: +34963503234

E-mail: amarques.etra-id@etra.es

Project websites & other access points: www.omniproject.net

Table of contents

1. SETTING THE SCENE	5
2. APPROACH	7
2.1 OMNI Objectives	7
2.2 Organization of the work	8
2.2.1 User Requirements and OMNI Specification	10
2.2.2 Development of OMNI prototype	12
2.2.3 OMNI System Evaluation	16
2.2.4 OMNI Workshops	17
2.2.5 OMNI Deliverables	20
3. RESULTS AND ACHIEVEMENTS	22
3.1 Architecture	22
4. OMNI PILOT SITES	27
4.1 Alicante	27
4.1.1 Site Objectives	27
4.1.2 Site Architecture	27
4.1.3 Alicante Site	30
4.1.4 Results	31
4.2 Chania	35
4.2.1 Site Objectives	35
4.2.2 Site Architecture	35
4.2.3 Chania Site	36
4.2.4 Results	37
4.3 Milano	39
4.3.1 Site Objectives	39
4.3.2 Site Architecture	39
4.3.3 Milano Site	40
4.3.4 Results	42
4.4 Paris	45
4.4.1 Site Objectives	45
4.4.2 Integrated traffic applications	46
4.4.3 Integration to OMNI	46

4.4.4	Paris virtual site	48
4.4.5	Results	49
4.4.6	Specific OMNI advantages demonstrated by this site	50
5.	CONCLUSIONS.	51
5.1	Innovation	51
5.2	Experience gained based on OMNI Pilots	52
5.2.1	Viability of a generic, open and flexible model of the road network.	52
5.2.2	Viability of the OMNI architecture customizable to site conditions and requirements.	53

1. SETTING THE SCENE

ITS infrastructure, whilst increasingly necessary to cope with the growing demand for mobility of EU citizens, is a high value asset requiring large investments from Traffic Authorities and Public Administrations in general. It is therefore more than justified that the owners and operators of ITS infrastructures want to protect their investments, which very frequently are the result of many years of budgetary efforts.

In this context, OMNI responds to these needs by means of one strategic mission: to facilitate the integrated deployment of advanced Intelligent Transportation Systems and Applications, overcoming the legacy constraints imposed by existing infrastructure. Emphasis has been put on flexibility, openness and vendor-independency.

OMNI (Open Model for Network-Wide Heterogeneous Intersection-Based Transport Management) has been a 36-month EU project, carried out by a Consortium formed by a complementary mix of experienced technology providers (both industries and research institutes), universities and traffic authorities.

OMNI has developed a network-wide intersection driven model, which is generic, open and flexible. This model acts as an intermediate layer that isolates the actual network infrastructure from the applications that are using it. In this way, the model, which is infrastructure and vendor independent, facilitates the integration of advanced ITS applications. OMNI models the components existing in the road network (sensors, lanes, local controllers, ...) considering both, their physical characteristics and their functionality. The building blocks of this model are individual heterogeneous intersections.

OMNI model relies on a layered structure, in order to isolate the specific technological characteristics of the road infrastructure from the ITS applications that are using it. The core layer, i.e. the so called OMNI MOUN, contains enough knowledge to properly represent the road infrastructure below.

The OMNI MOUN is the core of the model, providing a repository of information and the methods for exchanging it. The MOUN is composed by seven packages: Information Exchange, Physical Layout, Control Layout, Physical Status, Logical Status, Monitoring and Configuration. In short, all together accomplish the following functions:

1. To manage the exchange of information among all the components of the model.
2. To monitor the physical status of the different devices constituting the road infrastructure of the traffic network. These devices are typically local controllers, sensors (loops, cameras, etc) and subsystems.
3. To define a complete model of the network, instantiating the relevant objects of the network and monitoring their dynamic behaviour. These entities may correspond to physical devices as well as to virtual objects (e.g. either elements of working systems, such as video sensors and traffic light groups, or traffic control concepts such as plans, stages or movements).
4. To set a traffic control model, that defines the basic structures and concepts (in terms of traffic control) to be used by the objects of the urban network.
5. To update in real time the dynamic status of the entities present in the urban network.
6. To report in real time the events produced and detected by the applications.

The OMNI MOUN is complemented by the AIL (the Application Interfacing Layout, composed by the interfaces between the MOUN and each particular ITS application) and the PIL (the Physical Interfacing Layout, composed by the interfaces between the MOUN and each particular device or subsystem). Both the AIL and the PIL are 'light' interfaces that can be easily developed by the vendors supplying each specific device or application.

2. APPROACH



This section describes the approach and the methodology applied to develop the OMNI Project towards the achievement of the objectives initially stated.



2.1 OMNI OBJECTIVES

The objectives of OMNI were stated in the Annex 1 of the Contract in the context of the scene described at the beginning of Section 1.

*“The **Project objective** is to develop a network-wide intersection driven model, which is generic, open and flexible. This model will not be infrastructure dependent and it will enable the integration of ATT applications”.*

This main project objective was translated into a number of concrete, measurable project **operational goals**. The following table summarises them:

Objective	Reached
Developing a network-wide, intersection driven model: this will act as an intermediate layer, which isolates the actual network infrastructure from the applications that are using it. OMNI will model the components existing in the network (sensors, lanes, local controllers, ...) considering both their physical characteristics and their functionality. The building blocks of this model will be individual heterogeneous intersections	 OMNIMOUN
Demonstrating this model in two prototypes, which will be composed by a set of technical specifications and a software product for exploitation. The prototypes will enable: <ul style="list-style-type: none">• To have a consistent view of all the diverse intersections forming the network and their related traffic components;• The smart integration of different applications and devices in pre-existing network infrastructures	 OMNI Final Prototype installed and tested in 4 sites with different characteristics

Objective	Reached
<p>Testing the flexibility of the model by the integration within a number of traffic networks of:</p> <ul style="list-style-type: none"> • Advanced video based sensors addressed to surveillance and traffic control • A set of ATT applications, namely: <ul style="list-style-type: none"> • Surveillance: an automatic incident detection application using video sensors will perform surveillance tasks. • Advanced Traffic Control Systems: a number of different adaptive traffic control strategies and architectures will be assessed • End user transport information on the web. 	 OMNI Final Prototype enables the integration of: AID VBC UTC Web
<p>Testing the openness of the model with respect to diverse user requirements and traffic infrastructures in 4 representative test sites: Alicante, Milano, Chania and a virtual test site in Paris.</p>	
<p>Testing the flexibility of the model with respect to different traffic management architectures: distributed, centralised, etc.</p>	

2.2 ORGANIZATION OF THE WORK

In order to achieve the above objectives, the Consortium of OMNI followed a workplan structured in a set of eight workpackages that covers from the identification of the users requirements to the evaluation of the final result.

shows how the work in OSSA was structured in different workpackages and the flow of information and outputs among them. The vertical distribution shows also how the workpackages have been scheduled along project life cycle, from top to bottom.

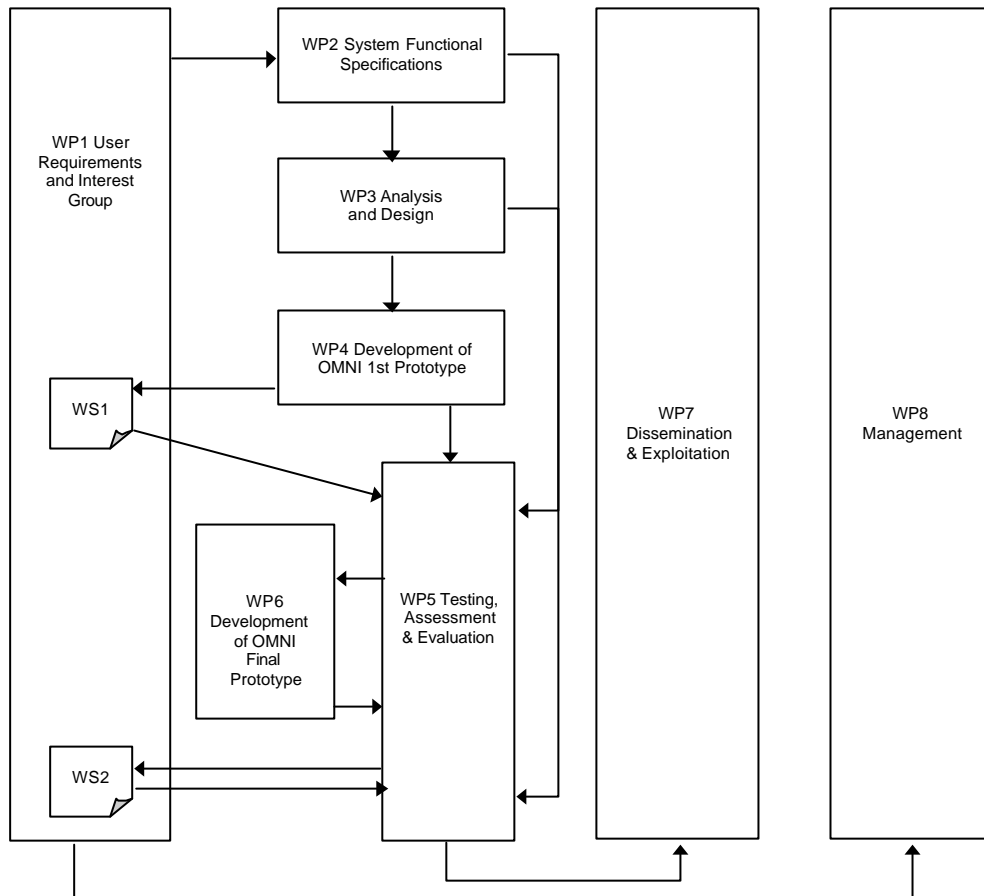

Figure 1. OMNI Workpackages flowchart

WP1, WP7 and WP8 have been horizontal to the project development, thus they started at the Project commencement and have finished with the Project, this approach has conducted the interaction to the rest of the WP.

The rest of this section is a description of the different tasks and technical solutions implemented in each one of the stages of the project development:

- User Requirements and OMNI Specification
- Development of OMNI prototype
- OMNI System Evaluation

2.2.1 USER REQUIREMENTS AND OMNI SPECIFICATION

The process of User Requirement identification and their formalization into technical specifications is the necessary preliminary work to prepare the development of the prototype. This process has been addressed in two workpackages in OMNI:

WP1. User Requirements and Interest Group

WP2. System Functional Specifications.

In WP1, the work began with the selection of the methodology to follow in order to implement WP1 User Requirements.

It was decided that the first action to implement was to produce a questionnaire in order to infer the user needs and requirements concerning urban traffic control and monitoring applications, devices and interconnectivity.

A draft of the questionnaire was produced, refined and validated by the users in the Consortium, then the validated questionnaire was distributed among a wide range of users. A total of 125 questionnaires were distributed to cities, research centres and universities, traffic control systems producers and consultants. These questionnaires were compiled and, as result of the study conducted, a set of user requirements were extracted from the answers given.

The group receiving OMNI questionnaires was selected to be representative of the leading town and city authorities in Europe, and the consultants, researchers and other experts who have a wide knowledge and overview of the current practice in traffic management. The secondary aim was to set up the core membership of the OMNI IG by recruiting those responding to the questionnaire.

Both the setting up of the OMNI IG, and ensuring early responses to the questionnaire were time critical requirements for OMNI project. Both requirements were successfully achieved, providing the key inputs to establishing User Requirements.

WP1 has also carried out the organisation of the three OMNI workshops:

- OMNI WS1 held in Chania the 14th of March of 2002
- OSSA WS3 held in Alicante the 25th of February of 2003.

where the Project results have been presented to the Interest Group and other relevant stakeholders and their feedback was achieved.

The main system requirements were extracted as conclusions from both User requirements and current systems capabilities and reported in deliverable D11.

As part of the effort of the OMNI project to develop a generic road network model that enables traffic devices, applications, systems and infrastructures to share and use the same information in an optimal way, the **system functional specifications** of OMNI were produced in **WP2**.

The specification work was split into three main tasks very strongly related: the first task was to specify the OMNI network model, the second to detail the applications requirements, and the third is to provide the devices specifications.

The workpackage was organised in five tasks each one dealing with one of the main areas OMNI is addressing:

- OMNI model specifications
- Advanced video based sensors
- Surveillance
- Advanced traffic control systems
- Customised web information to users

These tasks are reported inside three deliverables :

- D2.1 "OMNI Network Model functional specifications",
- D2.2 "ATT applications functional specifications" and
- D2.3 "ATT devices functional specifications".

The work began with the production of a planning for WP2, as well as a description of the contents expected for D2.1, D2.2 and D2.3 deliverables.

In order to specify the **OMNI model architecture**, the CONVERGE guidelines were followed. The overall architecture was defined considering the context, the functionality of the different modules (applications, devices and OMNI model), the control mechanisms, the

information flows, the physical implementation, the communication between modules and the management of the overall system.

Then the OMNI model itself was specified, describing its concept and functionality, its internal architecture and the enhancements needed to produce a network driven model from an intersection driven model, as well as the functional specifications of its GUI.

The **surveillance application** was specified following the next approach: general definition and description, components and information architecture.

The **traffic control applications** that will be used in the OMNI prototypes were specified. These advanced UTC systems are: UTOPIA in Milano, STU in Alicante, and CLAIRE/CRONOS in the virtual site of Paris. The specification followed the general pattern: general definition and description, components and information architecture.

It was studied the approach that should be followed for the production of the **web information applicative module**: the type of information required, the technology to be used, as well as the sources of information that the systems will use.

The specification of the web information system covered the following points: general definition and description, components of the system and information architecture.

The devices that will be used in the prototypes were described from the functional and operational points of view. These devices include **advanced video sensors** and **local controllers**.

In addition to this, the different site prototypes: Alicante, Milano, Chania and the virtual site of Paris, were specified by a detailed description of the site and the general architecture of the demonstrator.

2.2.2 DEVELOPMENT OF OMNI PROTOTYPE

The development of OMNI prototype was carried out in three workpackages:

WP3. System analysis and design

WP4. Building of the first prototype

WP6. Building of the final site prototypes

To carry out the design of OMNI prototype in WP3, it was followed an Object Oriented Approach where functional specifications generated in WP2 were formalised into UML specs.

The WP3 was divided into three tasks:

- OMNI Logical View,
- OMNI Application View and
- OMNI Physical View.

The OMNI Logical View dealt with the core of the OMNI model. The model was designed by the usage of UML specification and the Rational Rose tool. The core of the OMNI model, named MOUN, was divided into a set of packages in order to provide visibility of the elements of the network from different domains: Physical Layout, Control Layout, Logical Status, Physical Status and Information flows

The above listed topics formed the backbone of the OMNI Logical View, with information related to traffic observation and control.

Moreover two additional modules were defined into the OMNI Logical View, they are the Configuration and Monitoring modules which will enable the configuration of the model and the further monitoring of what is happening within the MOUN.

The OMNI Application View considered the analysis and design of the advanced video based sensors, the surveillance, new control systems and WWW information systems. It also provides an integration platform to supports all the standard mechanisms for information exchange among peripheral devices, applications and external systems.

The Application View detailed the aspects concerning the integration of the different applications with the OMNI model. Some subclasses were defined, in order to specify the functioning of the application interfaces for each of the applications mentioned.

The OMNI Physical View shows the real hardware and software components of the OMNI overall system. It allows different solutions for the applications and the platform implementation. Peripheral devices and external systems (owned by different organisations)

may present heterogeneous technologies and different building solutions, but they must respect platform constraints in information exchanging.

The Physical View detailed the aspects concerning the integration of the different devices with the OMNI model. Some subclasses have been defined, in order to specify the functioning of the device interfaces for each sensor, actuator and subsystem.

The analysis and design of the OMNI Logical View, the OMNI Application View and the OMNI Physical View was compiled in deliverables D3.1, D3.2 and D3.3 respectively.

The **development of the OMNI first prototype** was carried out in WP4. The first task was the definition and publication of the IDL's (DCOM interfaces) for the OMNI model packages. In this way the partners involved in the development of the applicative modules were able to implement the interfaces with the OMNI model in parallel with the development of the core OMNI model, the MOUN.

Then the OMNI MOUN packages were developed, this development included the basic information exchange mechanism, the functionalities of the different packages: Physical Layout, Logical Status, Physical Status, Control Layout and Information Exchange and the main entities and aggregation of entities of each package. Supporting documentation about how to use the MOUN and to implement the interfaces with the MOUN packages was also produced.

Additionally a basic graphical user interface of the OMNI MOUN which was later used to monitor the information exchange was also produced

The development of the OMNI MOUN packages was conducted in a parallel way, since it was implemented by different partners in the Consortium who worked in collaboration, a ftp site was available for exchanging code, executables, libraries and interfaces.

As part of the implementation process the partners tested the developed package, as a result of this testing process a set of bugs appeared which were corrected in new versions of the packages. The packages developed were: Physical Layout, Logical Status, Physical Status, Control Layout and Information Exchange and the main entities and aggregation of entities of each package, for each one it was also implemented the information exchange mechanism and a configuration data base.

Once the packages were developed and debugged they were integrated ones with the others in a modular system. Supporting documentation about the entities of each packages, how to use the MOUN and to implement the interfaces with the MOUN packages was also produced.

Additionally a basic graphical user interface of the OMNI MOUN which can be used to monitor the information exchange was also produced . This GUI has two layers, one textual where one can monitor and control all the entities of the MOUN and the other one graphical where one can monitor the status of the traffic network.

In WP6 the OMNI Prototype was installed and used within the different OMNI sites, each of these exhibiting strong specificities (different devices, applications, sizes, aims, etc.). The four sites were actually chosen as complementary as possible for this reason. We will show that OMNI was able to allow, on all sites, different traffic devices and traffic applications to communicate and work together.

The overall aim of Work Package 6 was the completion of the development, integration, installation and testing methodology of the final prototypes for all sites.

In effect, this implied :

- The development in each site of all specific communication software between field devices (controllers, traffic lights, loops, cameras, etc.) and the OMNI model.
- The development in each site of all specific communication software between the intelligent traffic applications (general user interface, urban traffic control, surveillance, congestion manager, web information to users) and the OMNI model.
- The definition on all sites of the overall architecture of the final prototype to be installed.
- The on-site integration of the specific applicative modules to be tested.
- The on-site configuration of the OMNI model and of the applicative modules.
- The definition of the test methodology to be used for each site, and the testing of the final prototype.

2.2.3 OMNI SYSTEM EVALUATION

The evaluation and assessment of OMNI results has been a very important work because it has enabled to obtain the necessary data and information, both quantitative and qualitative, to be able to provide consistent conclusions of OMNI results.

The evaluation process in OMNI has been organized in two phases: the first one addressed the development of a methodology for the actual evaluation. The second one focused on the data collection and analysis, that is on the Evaluation itself.

The Evaluation Plan was developed to provide the sites with the necessary guidelines to assess the objectives identified within OMNI. The validation methodology was based on the guidelines provided by the CONVERGE project, particularly Deliverable DVQ3.2 (Checklist for preparing a draft validation plan) and Deliverable DVQ5.1 (Guidebook for assessment of transport telematics applications).

Although the emphasis of the evaluation was on the technical testing of the OMNI model, the following general methods of measurement were used:

- The expert statement (technical evaluation, financial evaluation);
- Monitoring the prototype and demonstrator systems (technical evaluation);
- The questionnaire (user acceptance, impact analysis); and
- The focus group (impact analysis, financial evaluation).

As a means of evaluating the success of the overall OMNI system, an **evaluation model** was devised, with an input based on the associated evaluation objectives and indicators. A **success judgement vector** was then used to map the conditions and statistics of a particular measurement process to a **certainty value** (accuracy of result), **quality value** (whether the definition of success was met) and to generate a **score**. Finally, a judgement of the overall OMNI system can be obtained by expressing the average and minimum scores.

A comprehensive list of indicators was defined in D5.1. Table 1 shows the number of basic indicators measured at each test site. Wherever possible, common indicators were used, to enable a cross-site comparison of the results provided by the individual sites. For consistency, the indicators are again included within this deliverable, but are presented in a slightly different format to D5.1. This time, the Checklist Tables have been explicitly sub-

divided into basic indicators and aggregated indicators, and are contained in Appendices A and B, respectively. More details concerning the precise experimental design for specific indicators can be found in D5.1.

Group of basic indicators	Total no. of basic indicators	From Alicante	From Paris	From Milan	From Chania
Devices	25	10	3	13	2
Packages	48	26	29	11	9
Overall System	65	43	24	9	34
Total	138	79	56	33	45

Summary of Basic Indicators Measured at Each Site

Deliverable D52 provides detailed results of the evaluation of OMNI at each pilot.

2.2.4 OMNI WORKSHOPS

OMNI 1st Workshop

The 1st Workshop of OMNI took place in Chania (Crete) the 14th of March. The objective of the workshop was to present the interim results achieved after the implementation of OMNI first prototype to the community of experts and institutions interested and involved in the development of new European ITS Architectures. Although OMNI is not aiming at developing an architecture as such –instead the project addresses a model which would eventually support the deployment of specific architectures-, it was considered that the problem of ITS architectures was a neighbouring sector strategic to that addressed by OMNI.

As a result, more of 20 experts –including some of the key players in the area at an EU level-, met during a very fruitful day.

The workshop was structured around two sessions. During the first one, speakers from OMNI consortium presented to the audience a detailed introduction to the project, as well as

a snapshot of the results of the project so far. This first session also included an interesting presentation from Mr. James Boy, Strategy Manager from CEN, who gave useful hints on the process to follow in order to promote a wide adoption of OMNI project results at an international level. In particular, the new procedures to reach standardization consensus through CEN ISSS Workshops were discussed.

During the second session, eight papers on the topics addressed by the workshop but external to OMNI project were presented. These papers ranged from current EU initiatives in the area of ITS architectures to ITS applications requiring the support of advanced architectures.

Lively discussions took place during the two very interactive sessions.



OMNI 2nd Workshop

The second workshop

OMNI: Open Model and Architecture for Traffic Management'

held in Alicante the 25th of March.



The poster features logos for ETRA, IST, and OMNI at the top. The main text reads: "OMNI PROJECT 2nd WORKSHOP 'OMNI: Open Model and Architecture for Traffic Management' Alicante, 25th February 2003". Below the text is the OMNI logo and the website www.omniproject.net. The background shows a city street scene.

OMNI PROJECT

The OMNI project - Open Model for Network-Wide Heterogeneous Intersection-Based Transport Management - has developed a platform for the integration and use of new traffic management technologies and systems without the need of increment the investment on infrastructures. Due to the traffic & transport management information has been modeled in the OMNI Model, all the applications plugged-in to the system are able to exchange information in a common format. For example, in OMNI it is possible to use the same CCTV cameras that are used by traffic operators for supervising the traffic in a city, as the detector devices for an automatic incident detection system based on artificial vision. Likewise, it is possible to use the information the Urban Traffic Management System is using for traffic regulation, to be the source for a web application on traffic information.

The success of the system relies on the kernel of OMNI that is based on an open platform for communications and a generic datamodel that has a logical representation of all the infrastructures, devices and information necessary for the urban traffic management (topology of the road network, traffic devices, traffic management strategies, etc.) to which all applications and devices can access throughout simple interfaces.

The OMNI project is cofunded by the Information Society Technologies Programme in the V Framework Programme of the European Commission. The consortium that has carried out OMNI project is composed by eleven organizations (including technology providers, universities, consultants and users) from Spain, Britain, France, Italy, Greece and Poland.

PRELIMINARY PROGRAMME

25th February 2003

09:00 Welcome
09:15 Introduction
09:30 Presentation of OMNI System
10:00 Presentation of Milano Pilot
10:30 Coffee Break
10:45 Presentation of Chania Pilot
11:00 Presentation of Paris Virtual Site
11:15 Presentations from external experts
12:15 Discussion
12:30 Close of the workshop
13:00 Technical visit to the Traffic Control Room of Alicante Municipality to see OMNI.

Purpose

The purpose of the 2nd Workshop of OMNI is to present the results of the project, as well as the knowledge and experience gained from its piloting in the cities of Alicante, Milan, Chania and the Virtual Site of Paris (Metacor).

The reason for organising this workshop in Alicante is due to OMNI is currently installed at the Urban Traffic Control Centre of the city, being possible to show it running under real conditions and fully integrated with the SDCTU (Distributes Urban Traffic Control System).

This seminar is specially addressed to the authorities, traffic engineers, traffic operators and consultants on traffic & transport involved in traffic planning tasks.

The purpose of the seminar is to provide a discussion forum that, taking as starting point the solution implemented in OMNI, permits the attendants to analyse the advantages provided by OMNI, not only in terms of traffic management but also in the improvement of use of the existing infrastructures.



View of the workshop attendants



Introduction by Traffic Councilor of Alicante

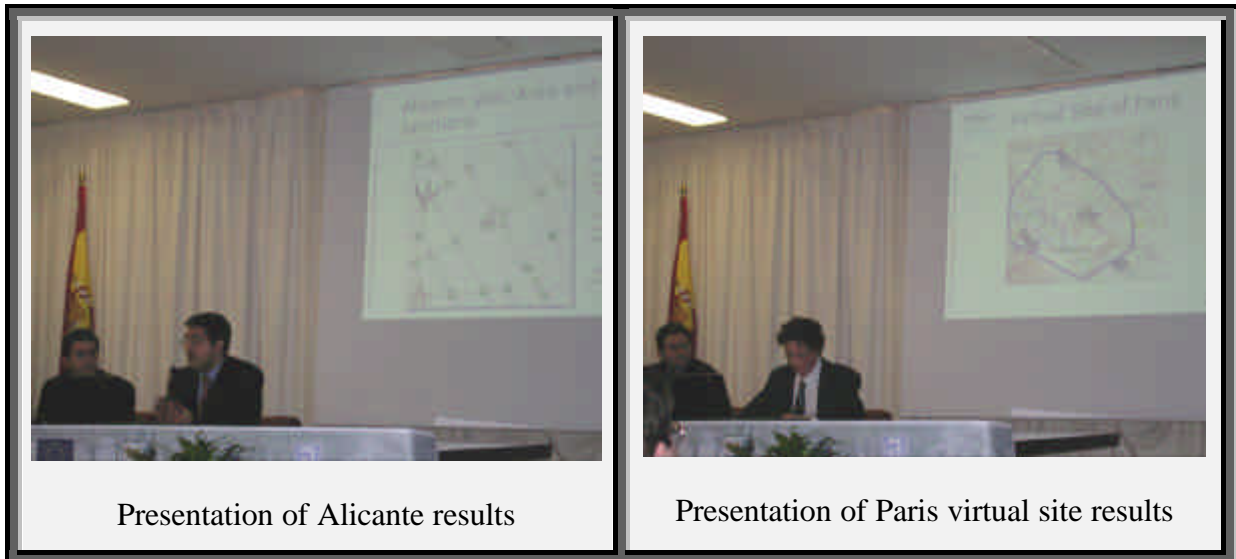

At the OMNI second conference the presentations were complemented with a Technical Visit to the Alicante Traffic Control Room where the OMNI System was presented to the attendants.

In order to provide more relevance to this event the OMNI 2nd WS was organised jointly with the 3rd WS of the OSSA project (of EC Growth Programme) in a 2 days conference on the “Application of the Information Technologies to the Urban Traffic Management”. Although each one of the workshops was organised to keep its own scope, a joint Press Conference was organised and the global event had an important impact on the local news papers and TV.

2.2.5 OMNI DELIVERABLES

During the three years of OMNI project, there have been produced 13 deliverables. Practically all of them are public and are available at

<http://www.omniproject.net/deliverables.htm>

The following table below summarises that list:

Del. no.	Del. name	WP no.	Lead participant	Delivery (proj. Month)
D1.1	User Needs and Requirements	1	ETRA	4
D2.1	OMNI Network Model Functional Specifications	2	INRETS	7
D2.2	ATT Applications functional specifications	2	INRETS	7
D2.3	ATT devices functional specifications	2	CITIOLOG	7
D3.1	OMNI Logical Analysis and Design	3	PASPA	10
D3.2	OMNI Application Analysis and Design	3	PASPA	10
D3.3	OMNI Physical Analysis and Design	3	PASPA	10
D4.1	OMNI First Prototype	4	ETRA	18
D5.1	Draft Evaluation Plan	5	TRG	23
D5.2	Evaluation Results	7	TRG	36
D6.1	OMNI Final Site Prototypes	6	CITIOLOG	30
D7.1	Dissemination and Use Plan	8	TUC	6
D7.2	Technology Implementation Plan	9	ETRA	18 36

3. RESULTS AND ACHIEVEMENTS

3.1 ARCHITECTURE

OMNI model is organized in three layers. The central one is the MOUN Model of Urban Network, which is the core of OMNI model and provides a general, device- and application-independent model of the network. MOUN provides methods for monitoring and control at both levels: physical and application. The bottom layer is the PIL, which implements device-dependent mechanisms aimed at mapping information coming from the devices into the general MOUN model, and vice versa. The top layer is the AIL, which implements application-dependent mechanisms aimed at mapping information from the applications into the general MOUN model, and vice versa. Subsystems need both AIL and PIL levels, since they are exchanging information at application and physical level.

Both PIL and AIL rely on MOUN, in the sense that they exploit the general abstract interfaces provided by MOUN. They have specific implementations depending on specific demonstrators and sites. On the contrary, MOUN is a general purpose and highly re-usable package which is expected to be exploited without changes in each demonstrator.

Therefore MOUN is both device- and application-independent (i.e., it is a fully re-usable component), whereas both AIL and PIL have specific implementations for specific devices, applications or subsystems.

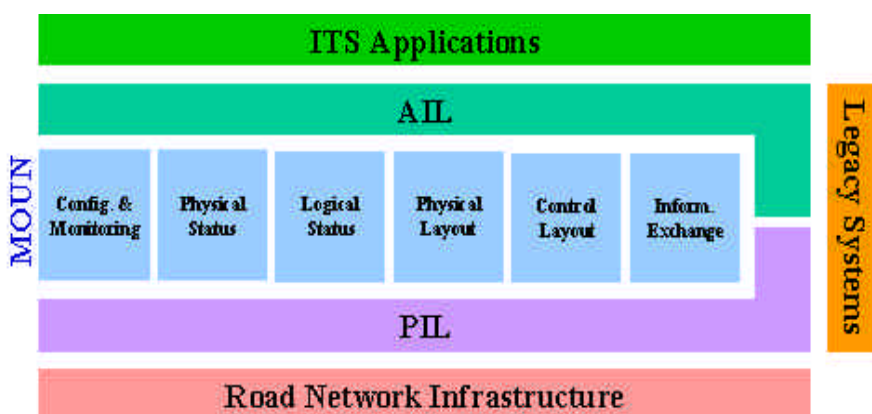

Figure 2: OMNI Architecture

In addition to the functionalities for configuration and monitoring of OMNI System performance, the MOUN has five packages with specific purposes:

- **Information Exchange Package.** This is a process manager to monitor the control and information flows in the OMNI architecture. It does not deal with application domain entities, but defines classes which control the dynamic behaviour of the system and the mechanism for information exchanging among entities. The dynamic behaviour can be defined without changing the OMNI code. This is a basic requirement because each installation must meet specific constraints due either to the applications or to the devices.
- **Physical Layout.** This package includes classes which model the static layout of the urban network. Entities in Physical Layout (Zone, Gate, Lane, Area, Junction, link, etc.) are associated to logical entities (Observers and Sensors). This provides the bridge between the static structure of the traffic system (the topology of the network) and the observation/control strategies.
- **Logical Status package.** This package includes classes modelling the dynamics of the traffic system. These classes don't depend on technological and implementation issues. They provide an abstract view of the dynamics of the traffic system by modelling concepts strictly related to the application domain (i.e., traffic control), and do not model concepts related to system administration, which are dealt with by classes in the Physical Status package. Devices use the classes inside the Logical Package in order to communicate the applications their logical status and to get the control commands from the applications
- **Traffic Control.** This package includes classes and associations modelling basic concepts of traffic control, e.g. plans, time sequences of colours for traffic light groups, time schedules, strategies. These classes do not depend on technological and implementation issues. Objects and links that instantiate classes and associations of Traffic Control package provide an abstract representation of the intersection control layout. They provide the traffic control concepts that will be further used by traffic control applications (AID, VBC, CM) and road devices (controllers and subsystems).

The model has been designed in order to cover different traffic control strategies (plan formation, plan selection, and so on).

- **Physical Status package.** This package includes classes related to system administration (configuration, monitoring, failure management, switch between operating modes, and so on) of components of the field infrastructure. In principle, objects in the Physical Status package should NOT be visible to individual traffic control applications (VBC, AID, CM, etc.); instead, they should be used by system administration applications only. For this reason, any field device will be described by the OMNI model according to two complementary views: Physical Status describes its administrative aspects (e.g. a FieldLight is burnt, a FieldController is working in centralised mode, a FieldVMS is connected, etc.) while the Logical Status describes its logical behaviour (e.g. a TrafficLightGroup has red colour, a LogicalLC is starting the third stage, a LogicalVMS is showing the “HelloWorld” message, etc.).

AIL and PIL layers provide applications and devices with the necessary interfaces for interacting through OMNI MOUN:

- **AIL:** The application interfacing layer (AIL) is composed by the interfaces between the MOUN and each particular application. Since the MOUN is generic and application independent, in order to interconnect applications which are *not-OMNI compliant* the application vendors have developed these AIL interfaces (a different one for each application) which use the DCOM interfaces exposed by the MOUN entities for communicating with the applications.
- **PIL:** The physical interfacing layer (PIL) is composed by the interfaces between the MOUN and each particular device or subsystem. Since the MOUN is generic and infrastructure independent, in order to interconnect physical devices which are not-OMNI compliant the vendors have developed these PIL interfaces (a different one for each device) which use the DCOM interfaces exposed by the MOUN entities for communicating with the network infrastructure.
- **Applications:** seven applications will be used in the final prototypes of OMNI at the different sites:

- AID: the Automatic Incident Detection system, which will be demonstrated in Alicante and in the virtual site of Paris.
 - CM Claire: The Congestion Manager Claire, which will be demonstrated in the virtual site of Paris.
 - STU UTC
 - Surf2000 UTC: The Urban Traffic Control system Surf2000, which will be demonstrated in the virtual site of Paris.
 - VBC Cronos: The Video Based Control system Cronos, which will be demonstrated in the virtual site of Paris.
 - Web Alicante: a web showing the congestion status and the incidents in the main roads of the city.
 - Web Chania: a web showing the congestion status of the main roads of the city.
- Devices:
 - INDIA4 Sensor: video based sensor to be used in the Alicante site.
 - Alicante Local Controller: local controllers to be used in the Alicante site.
 - AIP Video Sensor: this video sensor, developed by AIP will be integrated and tested just in lab.
 - Subsystem UTOPIA: one of the subsystems which will be integrated in the Milano site.
 - Subsystem SIGMA: one of the subsystems which will be integrated in the Milano site
 - LC MIGRA: the local controller of the Chania site, which measurements from the electromagnetic loops are used to calculate the congestion status of the roads.

The figure shows this layered architecture:

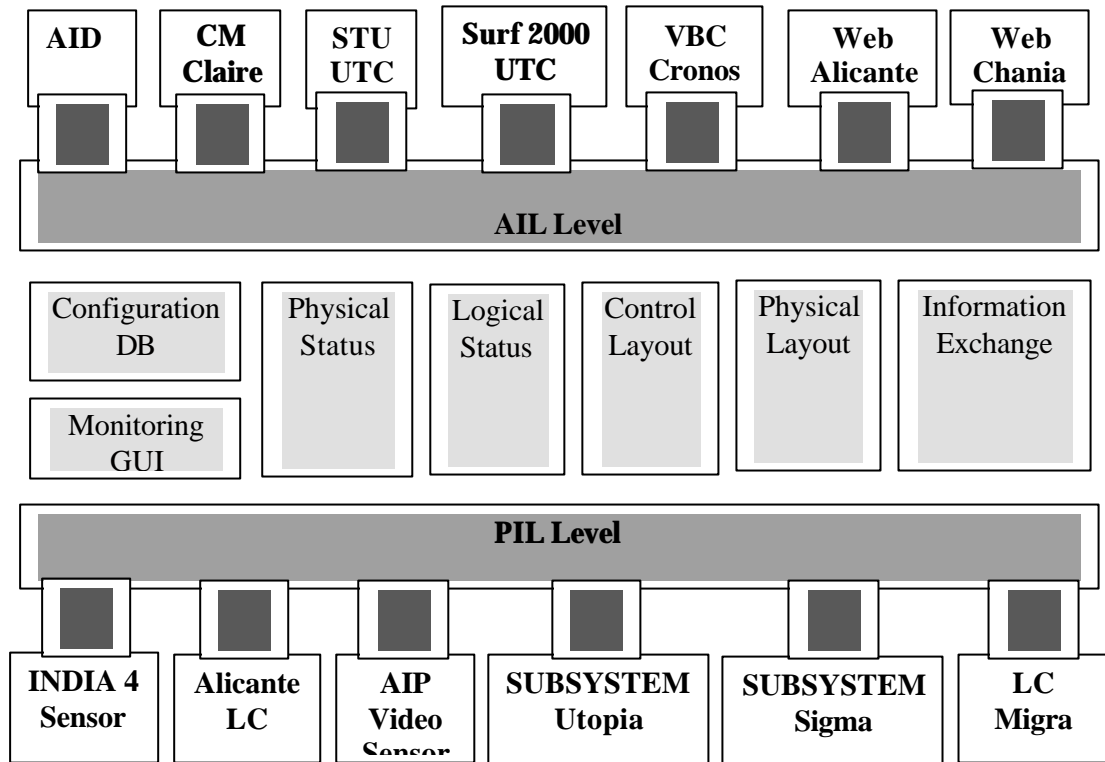

Figure 3 Layered Architecture

4. OMNI PILOT SITES

OMNI Prototype has been installed, tested and validated by the users of the four Pilot Sites. Each one of the OMNI Pilots has its own characteristics and has integrated existing infrastructures with other OMNI compliant systems and applications according their evaluation plans.

This section describes each one of the OMNI Pilots and the impact of its application in each site.

4.1 ALICANTE

4.1.1 SITE OBJECTIVES

The Alicante site had 3 main objectives:

- integration of an Automatic Incident Detection System (INDIA Citilog) with Alicante traffic controllers (ETRA CD), for advanced detection considering the state of traffic lights;
- integration of loop sensor data, plus incident detection and video measuring provided by AID (INDIA Citilog) with the functionalities for traffic state evaluation of a Urban Traffic Control Sytem (ETRA SDCTU); and
- providing the evaluation of the traffic status to a WWW application for public use.

4.1.2 SITE ARCHITECHTURE

An overview of the architecture of the Alicante demonstrator is shown in Figure 6.

Integrated applications

Four applications have been integrated to OMNI in Alicante.

Two of them already existed, and have been integrated without effort thanks to the development of a suitable interface:

- SDCTU, ETRA urban traffic control system
- INDIA, Citilog automatic incident detection system

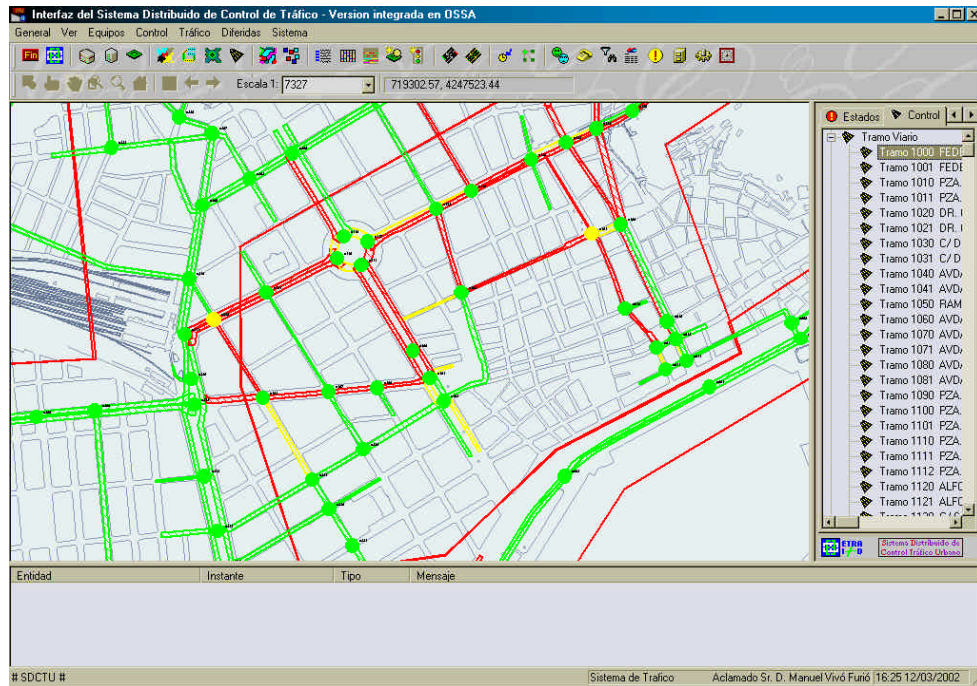

Figure 4: ETRA SDCTU GUI

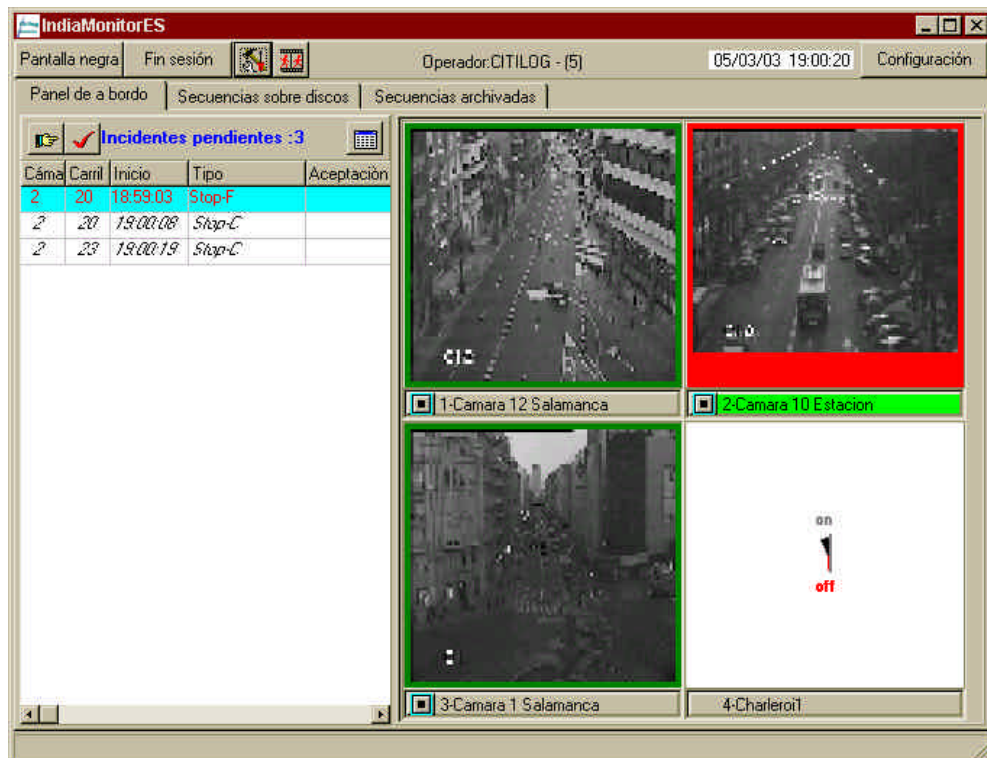

Figure 5: Citilog INDIA GUI

The other two did not exist before the project, and have been useful for demonstrating the ease for integration of new tools:

- A Web Service for traffic information
- OMNI GUI, the tool for configuring/monitoring OMNI

The following diagram illustrates the whole prototype architecture:

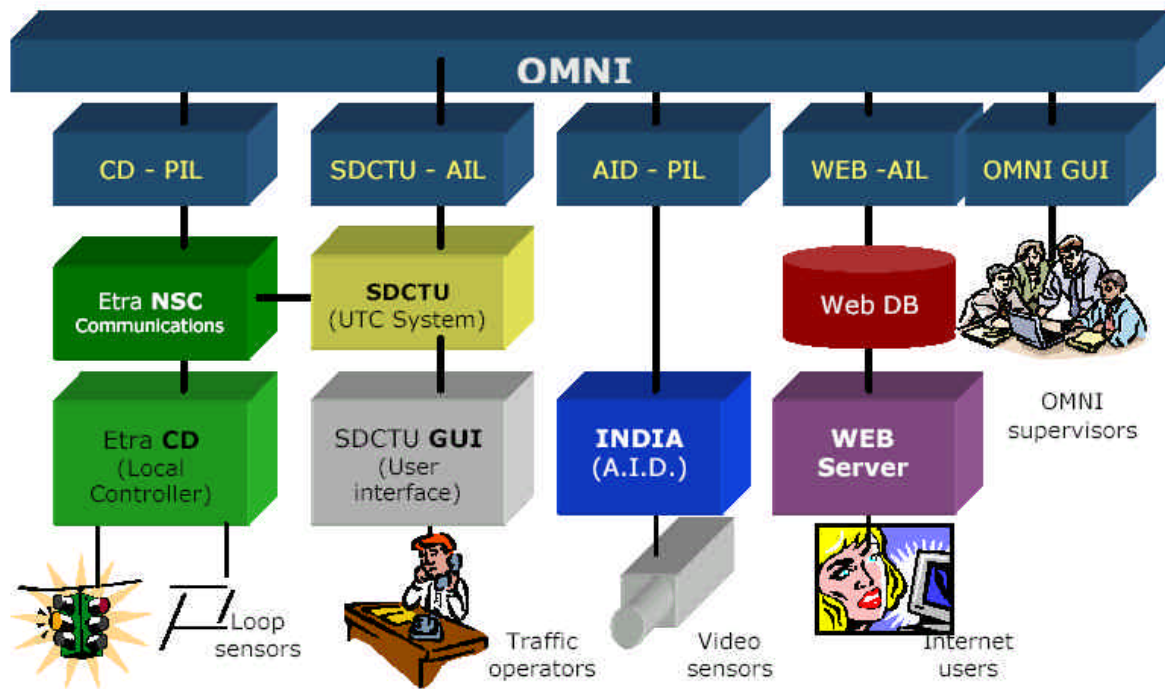

Figure 6: Architecture of the Alicante OMNI Demonstrator

Integrated devices

- ETRA CD traffic controller
- ETRA Loop Sensors
- Alicante video surveillance system cameras

It has to be pointed that all these devices were already installed in Alicante, but video cameras had not been previously integrated with any other application or device: they had been only observed visually by operators. With OMNI, these devices have been reused without any additional cost.



Figure 7: Two sample devices: traffic light and video camera

4.1.3 ALICANTE SITE

OMNI was demonstrated in the central area of Alicante. The central area was chosen for the following reasons:

- it is the area with the most traffic problems;
- it is the origin and destination of most vehicle movements, and therefore of most interest for a public information system;
- the different junctions in the area have a high dependency between them. For instance, congestion or traffic control decisions at one junction rapidly affect traffic at adjacent junctions;
- many public transportation lines start in the central area; and
- appropriate infrastructure (such as cameras and loop detectors) already existed at many of the important junctions of the area.

A site description of the Alicante test site is shown in Figure 8.



Figure 8: Description of the Alicante Test Site

4.1.4 RESULTS

Technical testing

From the results of the structured technical evaluation process, both in laboratory and in site, the following conclusions were obtained.

- the procedure of connecting / disconnecting the Local Controller (i.e. the corresponding device manager) with the OMNI system was always successful;
- measurements of the loop and video sensors were fully received and stored in the OMNI model;
- the OMNI model did not affect the operation of the loop and video sensor;
- all appropriate notifications between Local Traffic Controller and OMNI model were properly received and stored;
- there were no substantial delays in traffic plan update (in the Traffic Controller) caused by the OMNI model integration;

- the number of alarms detected in the LC was not affected by integration with OMNI: an increase would mean that integration is generating additional failures and a decrease that alarm detection is failing;
- the rate of incident (proper and false) detections was not affected by integration with OMNI;
- resistance to all weather conditions and traffic congestion was observed;
- all data regarding the traffic status and detected incidents from AID system was collected and transferred to the system operator without substantial delays;
- OMNI has proven its ability to generate meta-alarms defined as logical combinations of single-camera alarms;
- integration with the UTC package was also successful, all data has been received, stored and/or transferred in real-time conditions without delays;
- the traffic monitoring system integrated with OMNI was able to monitor the network as a whole or divided into surveillance sections and to provide the current traffic conditions;
- the web site was robust, working with proper refresh rate and provided information consistent with the UTC system;
- the representation of the OMNI model entities in the GUI package was correct;
- GUI provoked no functional failures interrogating or changing the state of applications / devices;
- the different views provided by the GUI application were consistent; and
- commands provided in the GUI were correctly updated in the model entities.

User acceptance

All measured indicators were of high quality, meaning that users reported overall satisfaction, usefulness and ease of use, especially based on:

- incident detection abilities;

- comparison of change in congestion;
- comparison of change in travel times on different routes;
- comparison of changes in number of stops and time spent at stops; and
- web site properties including:
 - ease of reading and understanding the information;
 - accuracy and relevance of information;
 - speed of receiving the information;
 - usefulness of incidents / roadwork's information; and
 - usefulness of congestion information.

Impact analysis

Globally, the OMNI site prototype in Alicante has demonstrated that it is capable of offering the following benefits to users:

- The cost of making sources of information available to different applications is significantly reduced.
- The functionalities obtained from the systems can be extended without replacement of infrastructure.
- New needs regarding traffic management and information processing can be satisfied with much less cost than without a common platform and model like OMNI.
- The scalability and flexibility of the platform facilitates the addition of new systems and devices to the traffic infrastructure.
- Traffic managers and operators can make better use of information, that is provided to them integrated and transparently, without having to worry about the source of information.
- Data previously existing in proprietary formats is now available in standard formats for its reuse through OMNI platform.

- Additional tools have been produced for traffic management and public information.
- Traffic data, previously cloistered inside traffic systems can be accessible for the public through the use of IT technologies (Web, WAP, SMS, etc.)

4.2 CHANIA

4.2.1 SITE OBJECTIVES

Chania suffers daily from major congestion during the morning and evening peaks, especially during the summer months. Therefore, the main focus of the Chania site was to install a WWW-customised traffic information system that, via the OMNI network model, collected and disseminated real-time traffic information to the network users. The traffic information displayed on the web was collected from detector loops installed at strategic network locations, and other sources such as traffic police reports, etc.

Users can access the website and see the traffic conditions on those roads for which traffic information is available. This is accomplished by connecting the web site to the MIGRA traffic system that provides traffic data from 17 loop detectors every 90 seconds. The demonstrator also provides information concerning addresses, shortest paths, points of interest etc.

4.2.2 SITE ARCHITECTURE

An overview of the general architecture within the Chania site is shown in Figure 10.

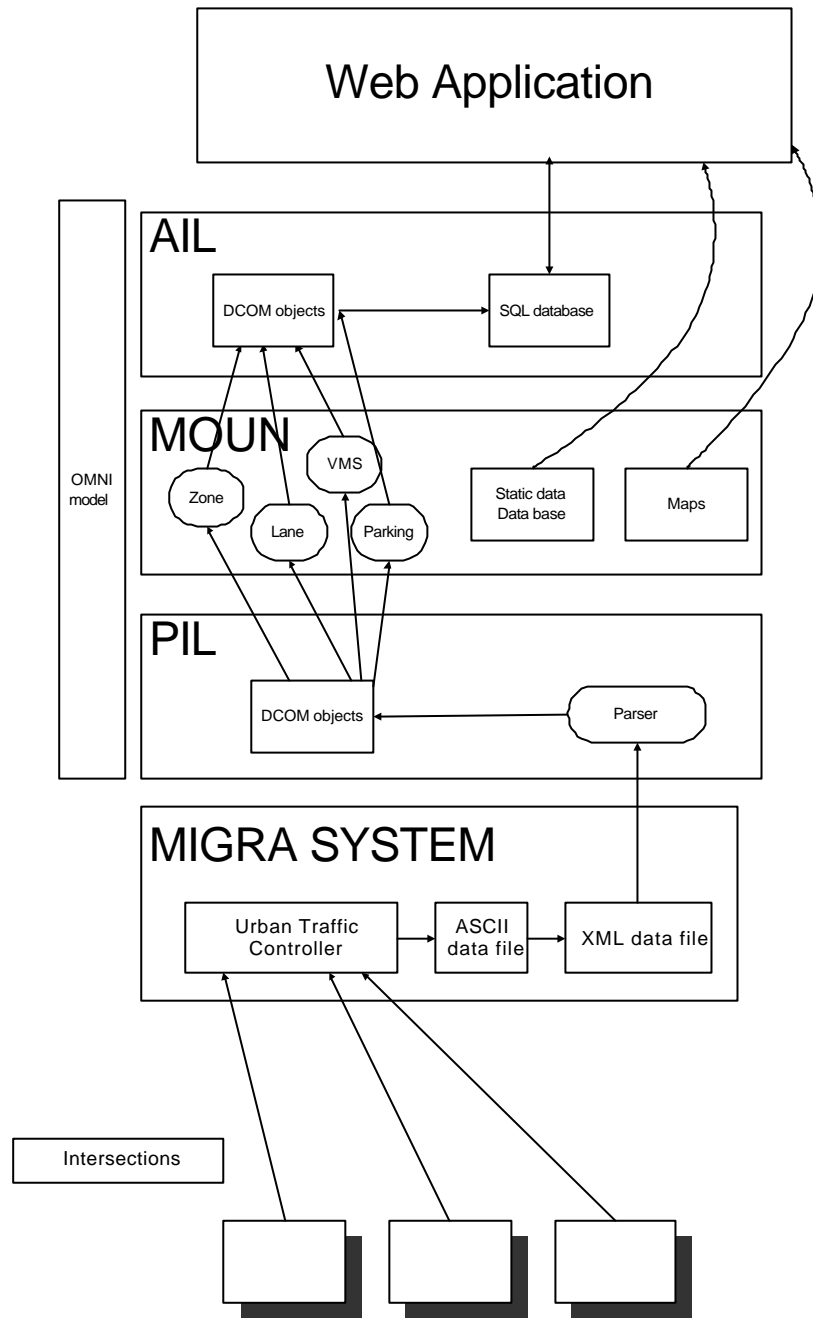

Figure 9: General Architecture for the Overall System within Chania

4.2.3 CHANIA SITE

The website application is focused on the city center of Chania, consisting of some 26 signalised junctions (see Figure 10). 22 of these junctions are controlled in co-ordination, while the remaining 4 are controlled in isolation. The traffic conditions of the network are

monitored on a 24-hour basis via some 45 induction loops that are connected to the local controllers for the micro-regulation of the signal control plans in real-time and to the SIEMENS - MIGRA CENTRAL computer for network co-ordination and monitoring purposes.



Figure 10: Chania site area

4.2.4 RESULTS

In the Chania site, the installation of the OMNI software facilitated the successful deployment of a web site providing real-time traffic information for internet users, along with information about the urban network itself. OMNI has provided a transparent and clear software background, which does not degrade the operation of the critical traffic monitoring and control system (MIGRA). Based on this software infrastructure, future extensions of the hardware infrastructure, in terms, e.g., of additional sensors of the same or different kind, can be handled more efficiently through reliable information reception and transmission among the various installed systems via the OMNI model. Thus, the site is able to consider the

future installation of additional advanced IT systems and technologies with more confidence and reduced effort. OMNI has reduced the effort required for the integration of the different systems, and has engineered an easy way of coordinating and managing the tasks associated with their co-operation. The benefits from the installation of OMNI, will continuously become more visible as more ITS applications are launched in the Chania site.

4.3 MILANO

4.3.1 SITE OBJECTIVES

The emphasis of the OMNI demonstration in Milan was to integrate two different UTC systems with the OMNI platform and to assess their co-existence and co-ordinated operation. This would consequently lead to standardisation and independence of the technology in the Milan Urban Traffic Centre, easing the use of different systems and applications, and freeing the installation of future and added-value ITS applications from tight technological constraints. The demonstration also involved the definition of suitable strategies to execute improved co-ordinated overall control of the test site.

The two UTC systems involved in the Milan OMNI demonstration differed from each other because:

- they concerned two contiguous urban areas, with a different layout and a different number of intersections; and
- they were based on alternative control criteria, i.e. plan-selection vs. adaptive control, which are traditionally incompatible with each other.

In addition, both systems were characterised by the following features:

- they were ‘closed’ systems, i.e. they were not originally designed to exchange information and to share data/commands with other systems;
- their functionality was based on a distributed architecture, i.e. algorithms and control mechanisms stayed in part on a central workstation (the UTC server hosted at the Urban Traffic Centre) and in part on peripheral devices (traffic controllers, processors and devices installed near the controlled intersections).

4.3.2 SITE ARCHITECTURE

An overview of the architecture of the overall system is shown in Figure 11.

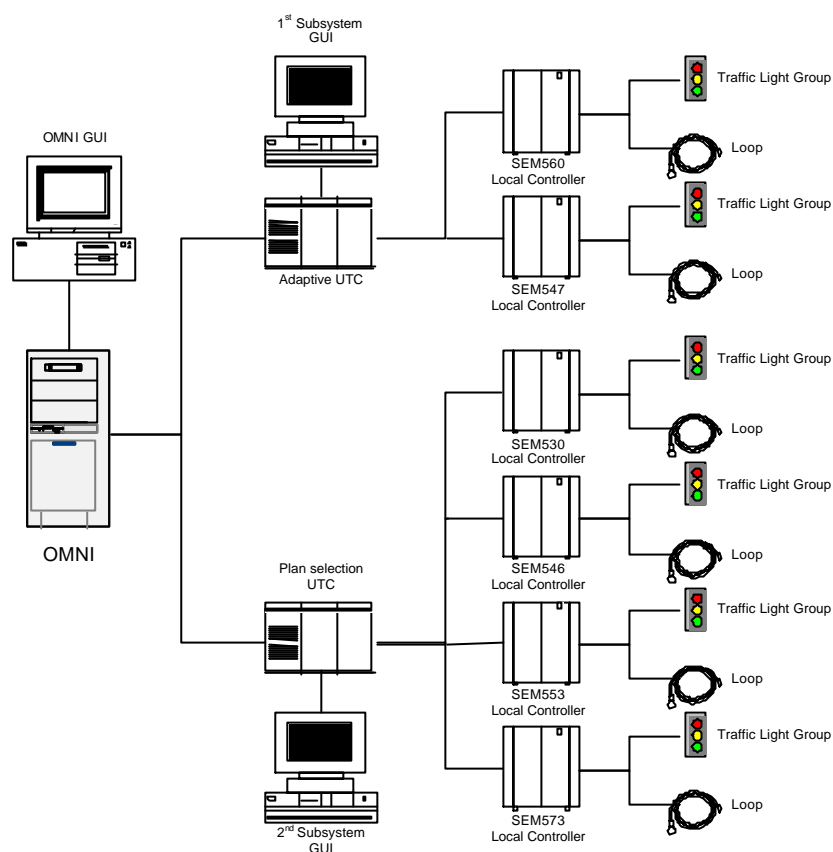

Figure 11: System architecture in Milan

4.3.3 MILANO SITE

The Municipality of Milan selected the specific OMNI demonstration site according to strategic and practical reasons. Although traffic managers wanted to apply the OMNI concepts to a significant urban area, featuring two different UTC systems (based on plan-selection and adaptive control), it was important that the experimentation did not greatly affect the regular congested traffic conditions in Milan.

The search for the optimal compromise between impact and effectiveness of the demonstration led to the choice of an area near the Milan Fair (*Fiera di Milano*), that now represents one of the European largest exhibition areas, and is subject to substantial traffic flows (both daily and in correspondence to special trade events). Since these situations concern a large urban area, co-ordination between contiguous UTC systems could have

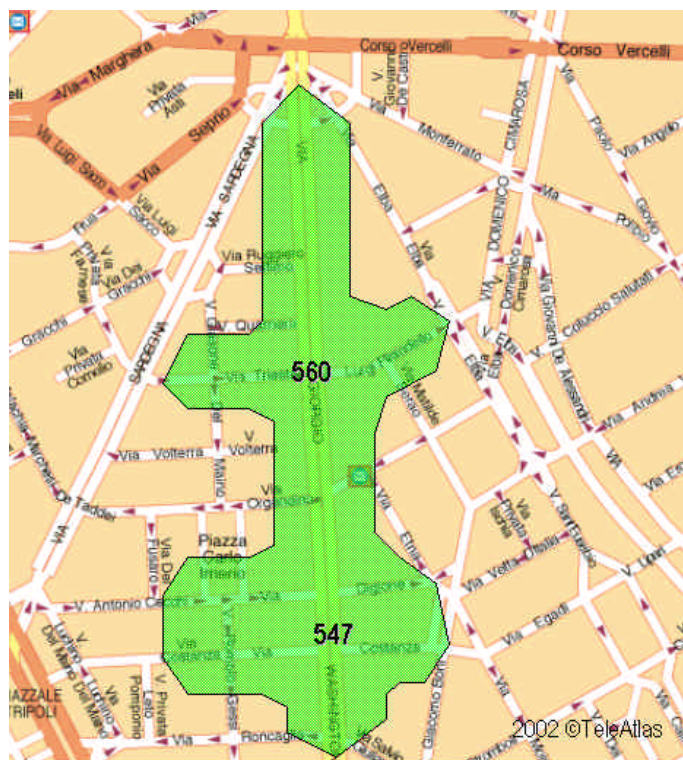

Figure 13: 2nd Micro-Area of the Milan Test Site

4.3.4 RESULTS

Impact analysis

During the demonstration activities in Milan, the OMNI platform fully assessed its potentialities and benefits. This added-value contribution can be schematically distinguished in **economical benefits** and **operational benefits**.

From an operational point of view, it's worth to consider that the introduction of the OMNI platform in the existing situation of Milan, i.e. multi-vendor and multi-infrastructure UTC subsystems, allowed the formulation of *network-wide traffic strategies*. In this way, it practically introduced extended application domain and control potentialities that didn't exist before. The availability of a network-wide application domain is even more important than the result of the traffic strategy itself, in terms of improved urban mobility. Traffic strategies more and more effective can be generated in future, according to acquired control experiences and more careful traffic engineering. The real innovation that OMNI introduced

in Milan is the availability of such control tools at the Traffic Control Room, enhancing the operation of UTC subsystems that otherwise couldn't support these inter-operative and trans-platform features.

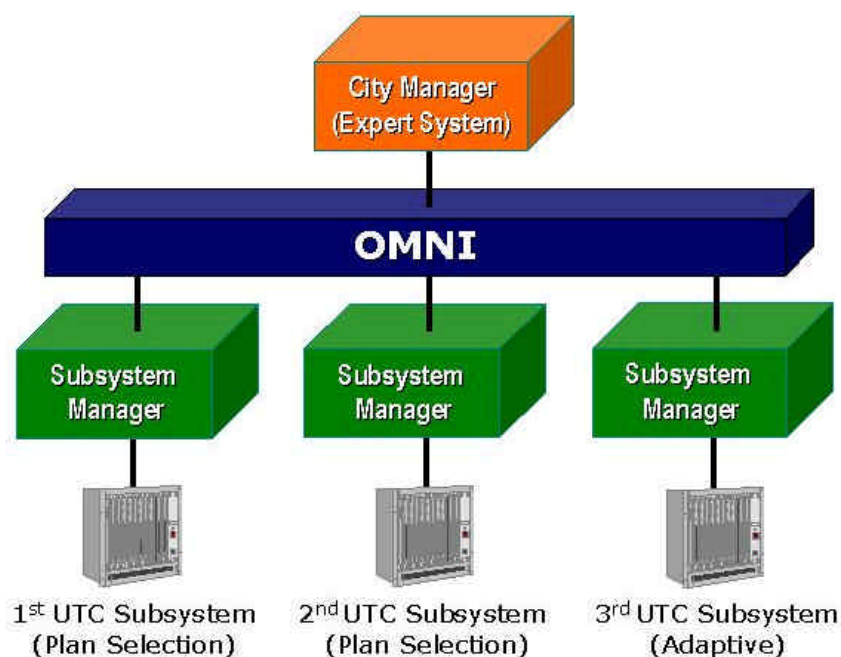

Figure 14: Evolution of traffic management through the OMNI platform

From this added-value base, the OMNI platform can effectively evolve in the future years, becoming more and more a complete suite, allowing the smooth integration of a large set of ITS applications (e.g. congestion manager, emergency managers, fleet managers, etc.). According to traffic managers operating at the Traffic Control Room, a very useful evolution of the OMNI platform in Milan should bring to a solution similar to the one reported by the previous picture. During the OMNI demonstration in Milan, traffic operators were in charge to select and to apply the more suitable traffic strategy, in accordance to the actual traffic conditions. The introduction of an “expert system” able to carry out this work in an automated way over a large urban area, will introduce a set of added-value features. This software module, developed according to concepts of Artificial Intelligent, should be smart enough to:

- To select, among a set of predefined strategies, the most appropriate one according to the actual traffic conditions, by monitoring the area under control and the relevant contiguous areas (i.e. pattern recognition features);
- To tune and to refine the existing traffic strategies, according to traffic conditions under evolution and periodic changes of the urban mobility (i.e. automated training features);
- To suggest new traffic strategies that seem more suitable to solve unforeseen and critical traffic conditions: these new tools should be certified by human operators before being applied to the urban network.

Financial assessment

From a financial point of view, the convenience of adopting the OMNI platform is straightforward: it comes directly from the results of the financial assessment of OMNI system. These results confirm that the OMNI platform is economically convenient for the innovation of the Traffic Control Room of a medium/big European city (such as Milan): for a medium installation of 150 traffic intersections, the economical benefits introduced by OMNI can be up to 40 % of cost savings.

4.4 PARIS

4.4.1 SITE OBJECTIVES

The specific aim of the Paris site was to connect a simulated site (called a “virtual” site) to OMNI. This site was real in the sense that it was a real part of a traffic network fed by real data but it was “virtual” in the sense that no actual installation was performed. Instead, the overall network was simulated in terms of static (e.g. geometry) and dynamic (e.g. traffic flow, signals) aspects.

The advantages of connecting a virtual site to OMNI were:

- to connect a large network to OMNI while maintaining a reasonable project cost;
- to prove the feasibility of integrating OMNI to a traffic flow simulation tool;
- to show the feasibility (in particular in terms of CPU time consumed) of integrating via OMNI a network of numerous intersections;
- to integrate several specific traffic applications;
- to offer demonstration facilities outside the OMNI Consortium.

The consequent requirements of having a virtual site were:

- a simulation traffic tool to simulate the site (the METACOR tool),
- simulated sensors and simulated traffic controllers inside the simulation tool,
- real data for feeding the simulation of real traffic flows.

The secondary objective is to integrate to OMNI a greatest number of traffic applications and to prove their easy connection.

These applications concern four domains : the surveillance, the control, the congestion domain and the simulation function.

4.4.2 INTEGRATED TRAFFIC APPLICATIONS

Six applications have been integrated to OMNI for the Paris prototype :

- An Automatic Incident Detection (AID) module which detects the queue length exceeding a threshold or never reducing queue. A reconstitution of the overall congestion is performed.
- A Urban Traffic Control (UTC) SURF2000 : this UTC manages all the intersections of the Ville de Paris. It is a library of traffic light plans managed by macro-control.
- A Video Based Control (VBC) CRONOS which is an adaptive control system. It controls zones of several intersections by optimising the delay over a time horizon. It provides traffic lights every second according to the traffic situation measured by video based sensors.
- A Congestion Manager (CM) CLAIRE : It detects congestion on the network, diagnosis the situation and provides recommendations of favouring or retaining the traffic on given links. It does not control directly the traffic by signals but it is an independent supervisory layer which provides recommended actions to the control system.
- METACOR the simulation tool which plays the role of the field.
- The GUI of OMNI

4.4.3 INTEGRATION TO OMNI

The architecture of the prototype for the virtual site is shown on the Figure 15:

METACOR simulates the devices (video and loop sensors, controller) and the traffic. It is connected to OMNI via the PIL interface.

The other applications (AID, SURF2000 UTC, CRONOS, CLAIRE, GUI) are connected to OMNI via the AIL interface

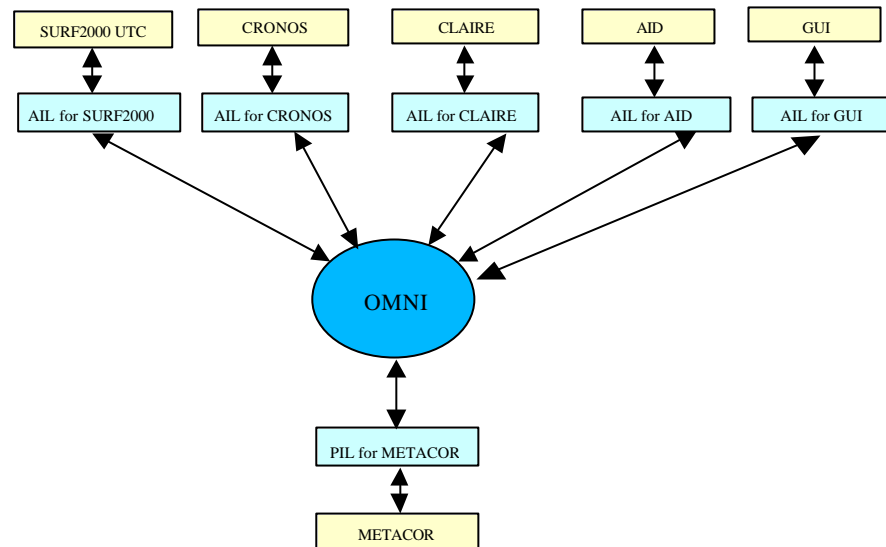

Figure 15 : General architecture of the virtual site integrated to OMNI

METACOR simulates the traffic every second. The traffic measurements and the traffic light colours are sent to OMNI via the PIL to be accessible to every applications. Each application has its own scheduling : one second for SURF2000, CLAIRE, the AID, the GUI. Three minutes for CLAIRE. They send their results to OMNI :

- the colours of signals for SURF2000 and CRONOS,
- the detected incident for the AID,
- the recommendations of favouring or retaining the traffic on given links for CLAIRE.

These results are used by METACOR for the next second or used by the other applications : for example the recommendations of CLAIRE are used by SURF2000 and CRONOS.

4.4.4 PARIS VIRTUAL SITE

Description

For testing the Paris prototype, a virtual site has been chosen. The site to be simulated is located in the south of Paris between the Bastille Place, the Lyon Station and Bercy. It is composed of nearly 30 adjacent intersections (representing an area of approximately 1.5 km x 1.5 km). This part of Paris is congested daily, particularly during the morning and evening peaks. The Lyon station belongs to this network. It is an important attractive centre in terms of vehicles, bus and pedestrians. The Place de la Bastille is also a main intersection. This network contains several of the roads along the Seine that are also strategic routes in Paris.

Initially, this network is managed by the UTC system SURF2000. A network of sensors (magnetic loops) provides traffic measurements (such as traffic flow and occupancy). A traffic light plan can be changed every 3 minutes.

CLAIRE is usually integrated to SURF2000 on seven intersections in order to manage the congestion situations (see Figure 16). For these intersections, CLAIRE analyses the traffic, detects the congestion and proposes recommendations to SURF2000 that chooses the appropriate traffic light plans.

Calibration

For the OMNI impact analysis, a first step has been to calibrate the test site : this stage has taken several months. The objective was to determine the turning movement rates for each intersection which minimize the distance between simulated and real sensor values. The optimisation tool BOX has been used during this step.

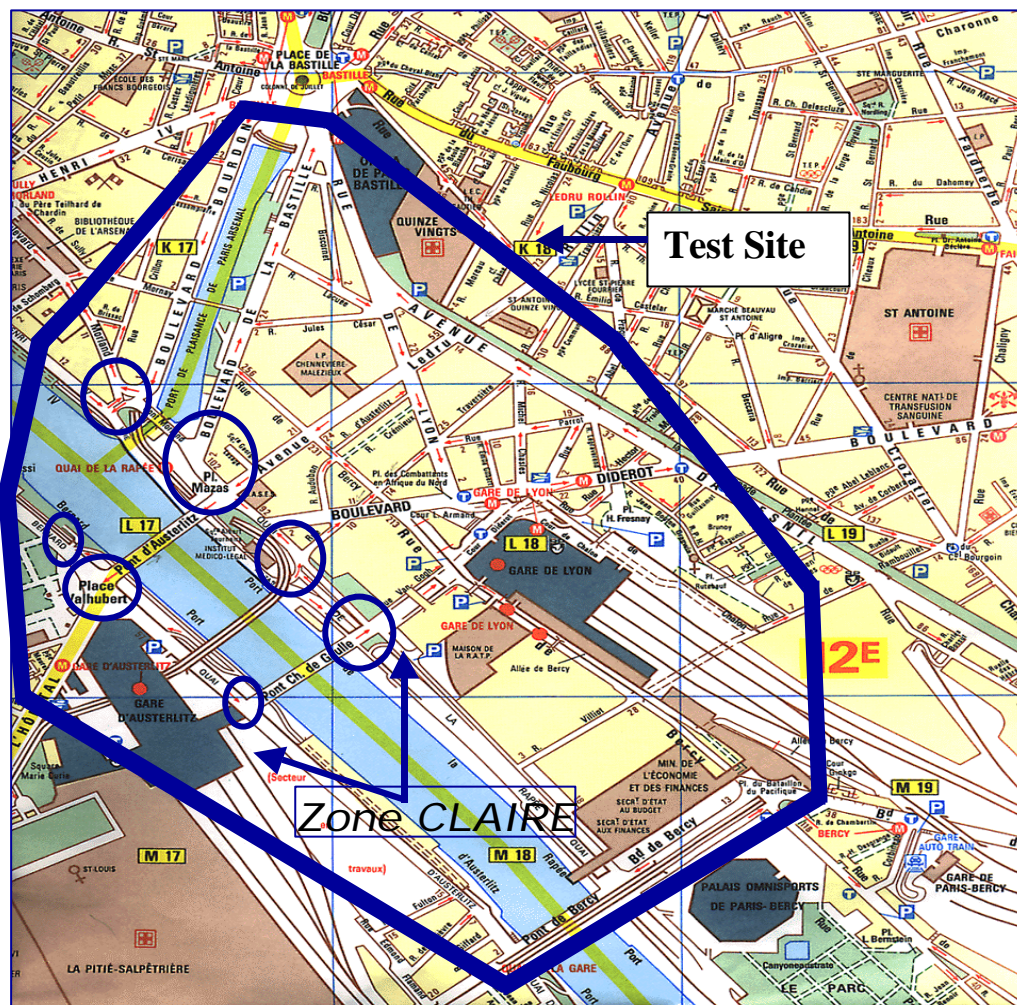

Figure 16: Virtual site of Paris

4.4.5 RESULTS

General testing

Each module and the overall system have been tested in laboratory.

The objectives were to assess the integration of CRONOS, CLAIRE, the AID, the SURF2000 UTC, the GUI applications and the simulated devices (METACOR) needed for their operation through the OMNI model, as well as assessing that this integration did not affect their functionality. It was also verified that the information exchanged was correct and that no modifications in the operation were observed by the integration (by comparing the results with the ‘without OMNI’ case where appropriate).

Impact analysis

The integration of several applications to OMNI have allowed to evaluate the benefits of using the integration of CRONOS to CLAIRE compared to SURF2000 UTC. Benefits, compared to SURF2000, have been realized by controlling a zone of the site by CRONOS (instead of SURF2000) and a little more benefits have been obtained when CRONOS uses the recommendations of CLAIRE before deciding the traffic light colours of the zone.

4.4.6 SPECIFIC OMNI ADVANTAGES DEMONSTRATED BY THIS SITE

The specific OMNI advantages demonstrated by the virtual site of Paris are :

- To have integrated to OMNI specific applications such as METACOR, CLAIRE, CRONOS which become OMNI configured.
- To easily allow cooperation between two or more applications : the results of one application can be used for the decision of another. This is what have been done on the Paris site for the VBC (CRONOS) and the CM (CLAIRE) or between SURF2000 UTC and the CM (CLAIRE).
- When using OMNI, installing cost per application and per intersection is divided by around a factor 20, because no specific interfaces are needed.

5. CONCLUSIONS.

At the end of the project, the main conclusion is that the OMNI MOUN is able to model the topology and traffic management infrastructures of any European city as demonstrated.

No changes on the current architectures, infrastructures and devices have been necessary to use OMNI in four different sites. In addition to the configuration of the logical representation of the physical infrastructures, the only one requirement to use OMNI is to implement the necessary interfaces for making the different components OMNI compliant. These interfaces are small pieces of software to be implemented by the component's providers. Guidelines to do this have been produced and successfully applied in each site.

5.1 INNOVATION

In spite of some undergoing activities, several activities are undergoing, none of the current initiatives is addressing the topics covered by OMNI. OMNI model will then complement the current initiatives in traffic systems integration and standardization. OMNI work does not just rely on the functionalities or the communications in the network, but also on the provision of the semantics of the network.

Nevertheless OMNI has taken profit of current standardization efforts in the framework of the EC, as ESCORT and KAREN, and is in contact with CEN in order to harmonize the OMNI model with the rest of European standardization actions.

The approach used by the OMNI model allows to connect and inter-operate existing devices and applications by mean of developing software interfaces towards the model. At the same time the model provides for a system independent interface to expose data and functionalities to new applications (i.e. advanced control systems, information systems). The demonstration pilots have demonstrated the feasibility and effectiveness of this approach.

Based on COM technologies , the technological approach followed for the implementation of the OMNI model facilitates the adoption of standard communication protocols; independence from operating systems; high level of scalability, and a distributed architecture.

5.2 EXPERIENCE GAINED BASED ON OMNI PILOTS

OMNI has been piloted in three different European sites –Alicante in Spain, Milano in Italy and Chania in Greece-. In addition, a fourth virtual site is being lab tested in Paris. A vast set of applications, ranging from different traffic control systems to video based incident detection, as well as the associated diverse roadside devices are being successfully integrated through OMNI in these sites.

5.2.1 VIABILITY OF A GENERIC, OPEN AND FLEXIBLE MODEL OF THE ROAD NETWORK.

As already mentioned the kernel of OMNI is the MOUN. It is structured in four main components:

- Registration / notification mechanism.
- Specialized entities for the different purposes, structured in 4 packages: Physical Layout, Physical Status, Traffic Control and Logical Status.
- MOUN Model database (implemented in MS Access).
- OMNI GUI

The OMNI GUI provides the necessary tools for configuring and monitoring the other three. The following figure shows the interface for the configuration of the OMNI MOUN database:

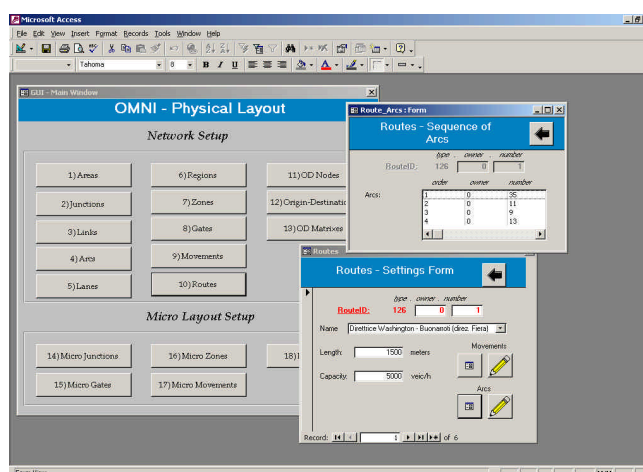

Figure 17 : OMNI MOUN Configuration Tools

At operation level the OMNI GUI, provides three types of windows (views):

- **Textual view:** shows the list of entities and textual description of the static and dynamic state of one of the entities or containers
- **Network level view:** shows the state of traffic in the network
- **Junction level view:** shows the state of the entities related to one of the junctions in the network

Thanks to this structure, the user can work with as many windows as desired, displaying and observing the concepts he or she needs and in the most suitable format (map or text). The different windows can be reshaped, tiled, cascaded in the way found most convenient.

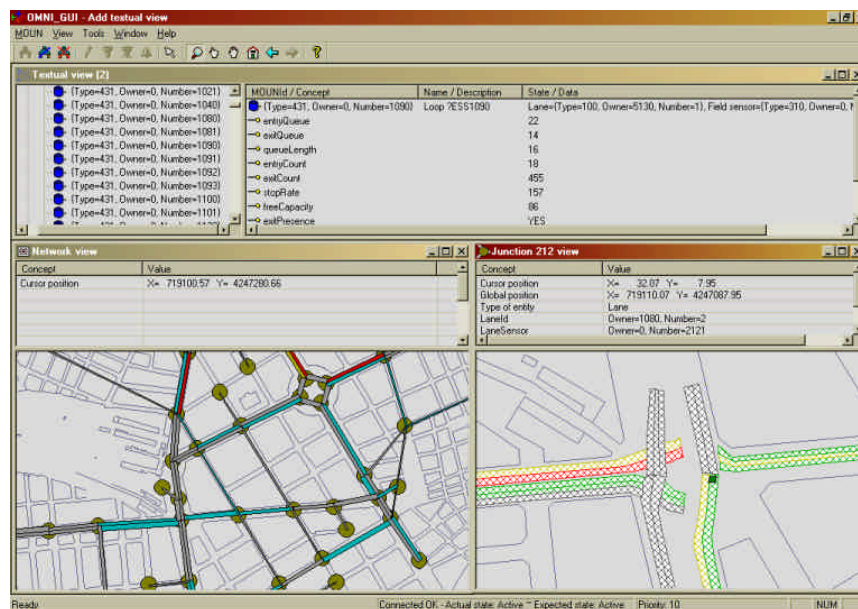

Figure 18 : OMNI GIU. Textual, network & Junction views of Alicante Road Network

5.2.2 VIABILITY OF THE OMNI ARCHITECTURE CUSTOMIZABLE TO SITE CONDITIONS AND REQUIREMENTS.

One of the main achievements of OMNI is the demonstration of the viability of the model developed under real conditions and for different sites with their own characteristics and needs. The work done for modelling and abstracting the concepts and devices for traffic

management has been successfully demonstrated in the four OMNI pilots. As OMNI platform relies on a layered structure, it has been possible to isolate the specific technological characteristics of the road infrastructure, from the advanced ITS applications that are using it. The central layer, i.e. the OMNI Network-wide Model MOUN, contains enough knowledge to properly represent the road infrastructure below. It has not to represent all the possible information about the infrastructure, but rather the significant one.

Then, for each pilot, different OMNI compliant components have been used according to the infrastructures available. A component of the OMNI system, both ITS application and field device, is considered OMNI-compliant when:

- It is able to connect correctly to the MOUN, and to disconnect too.
- It provides a suitable interface for the interaction with the MOUN, exchanging messages to co-ordinate its working with the evolution of the model.
- It is able to notify correctly any significant event to the MOUN.
- It is able to register itself to receive the updated status of an entity of the model, as well as a subset of entities.
- It is able to receive asynchronous notification about the changes occurred on an entity belonging to its list of registration.

In the case of Alicante, OMNI has been demonstrated by assessing heterogeneous intersections traffic control, plus AID and web based information service. The following functionalities have been implemented:

- Integration of an Automatic Incident Detection System (AID) with Alicante traffic controllers, for advanced detection considering the state of traffic lights
- Integration of loop sensor data, plus incident detection and video measuring provided by AID with the functionalities for traffic state evaluation of a Urban Traffic Control System (SDCTU)
- Providing the traffic state evaluation to a WWW application for public use.

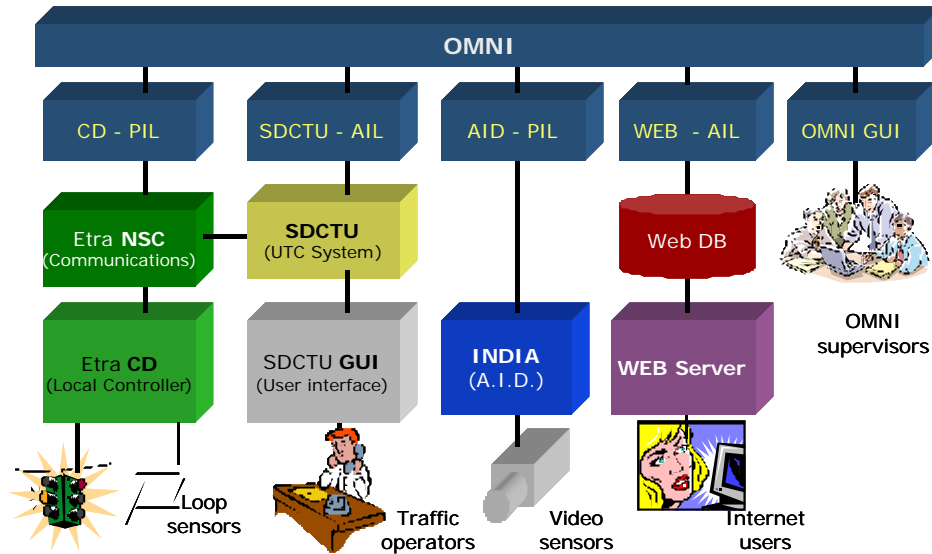

Figure 4: Alicante OMNI Pilot.

This architecture has been used for improving the traffic management in the city center by integrating the traffic control system with the video based incident detection application, complemented with a web application able to provide real time information on the traffic level in the principal streets.

In the case of Milano, the approach was different than in Alicante. The pilot focused in the management of a section of the road network with the intersection of two main avenues, each one is managed at present by different traffic control systems: UTOPIA and other plan selection STU.

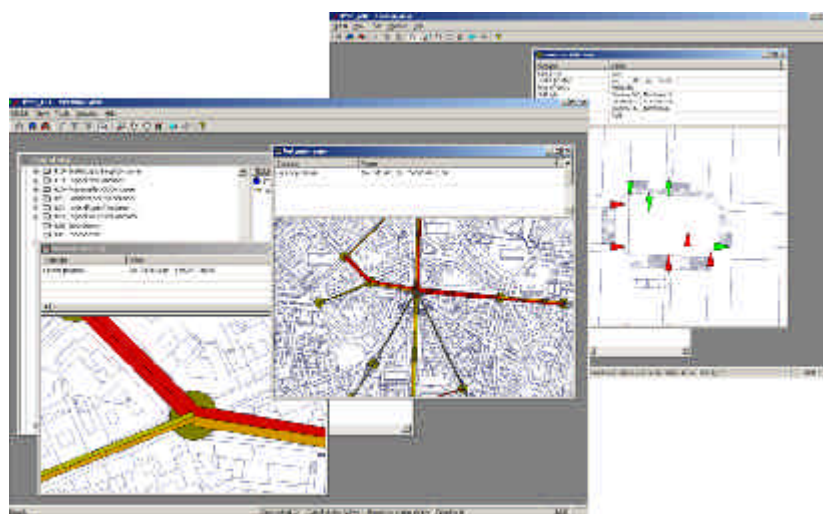

Figure 19 : Milano OMNI Pilot.

In the case of the Virtual Site of Paris, OMNI has been used to support traffic engineering and simulation tasks. In particular, it has been integrated with a simulation tool to evaluate the viability of the integration and operation of three traffic management applications (CRONOS, SURF2000 & CLAIRE) with the AID in the Metacor simulation infrastructure in a sample of 29 intersections of Paris:



Figure 20 : Paris Virtual Site.

In addition to the strictly direct application of OMNI to traffic management, it has also been demonstrated its usability to distribute the traffic information available on the system throughout other communication channels such as internet, to provide the drivers with information on the status of the traffic on their cities in real time. This feature has been demonstrated in the pilots of Alicante and Chania where, according to the OMNI approach the same model has been used but different designs have been prepared for the presentation of the information to the end-user. In the case of Chania, this information has been integrated in a portal with other information of the city, whilst the Alicante's application is able to provide pictures of the detected incidents.

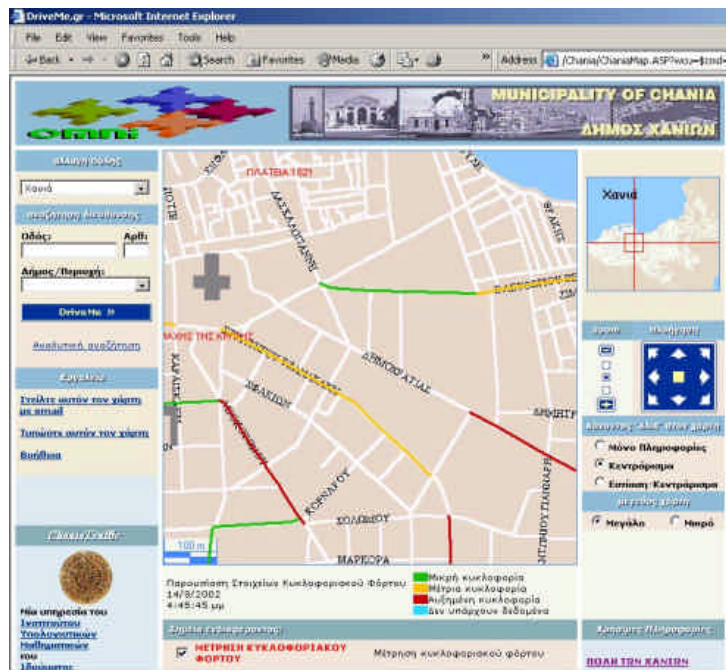

Figure 21 : Chania OMNI Web Application.

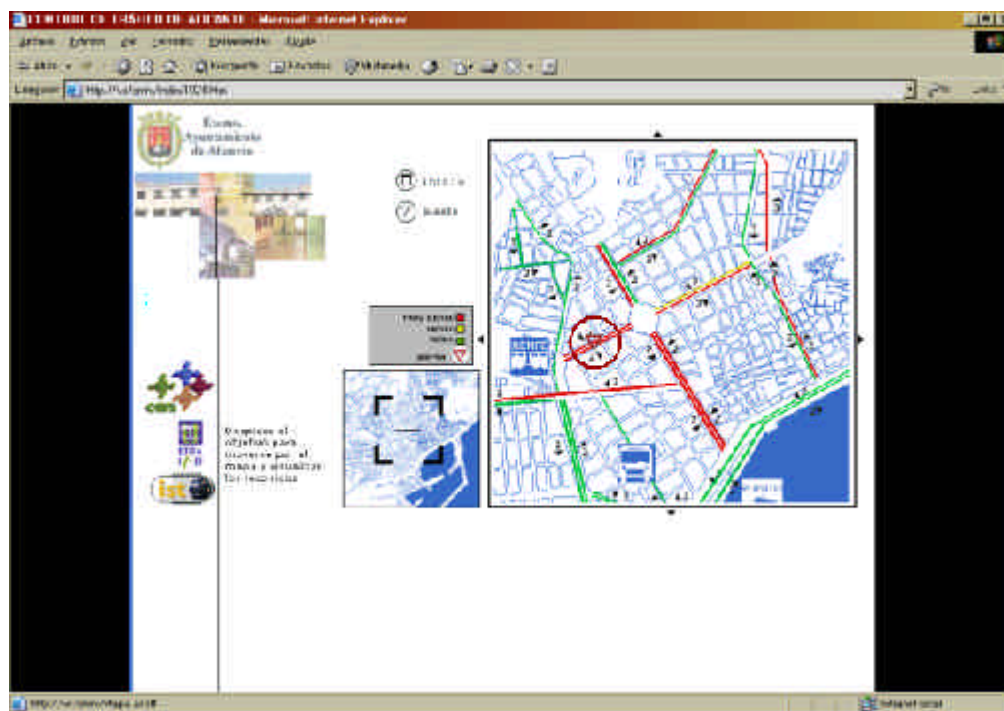

Figure 22 : Alicante OMNI Web Application.