

**GSA-227890 GRAMMAR****D1.4 Version 1.17*****Gap Analysis of GNSS Receivers and Technology*****Contractual Date of Delivery:** 02.06.2009**Actual Date of Delivery:** 09.06.2009**Editor:** Stephan Sand**Author(s):** *Armin Dammann, Ingmar Groh, Christian Mensing, Stephan Sand, Marco Detratti, Simona Lohan, Heikki Hurskainen, Helena Leppäkoski***Participant(s):** *DLR, ACO, TUT***Work package:** *WP1300 - Technology Gap Analysis***Security:** PU**Nature:** D**Version:** 1.17**Total number of pages:** 71**Abstract:**

The scope of D1.4 Gap Analysis of GNSS Receivers and Technology is to review the state-of-the-art for mass market receivers for the mobile terminal market, review the state-of-the-art for high-end Global Navigation Satellite System (GNSS) receivers and identify technology gaps that exist.

Given the investigations in D1.1 Market Definition and Core Technology Report on key core technological drivers and key core technologies as well as the review of state-of-the-art mass market receivers for the mobile terminal market in Chapter 1 and high-end GNSS receivers in Chapter 3 of this deliverable, the major technology gaps have been identified.

Disclaimer:

Executive Summary

The scope of D1.4 Gap Analysis of GNSS Receivers and Technology is to

- Review the state-of-the-art for mass market receivers for the target segment as defined in WP1100.
- Review the state-of-the-art for high-end Global Navigation Satellite System (GNSS) receivers.
- Identify technology gaps that exist.

Given the investigations in D1.1 Market Definition and Core Technology Report on key core technological drivers and key core technologies as well as the review of state-of-the-art mass market receivers for the mobile terminal market in Chapter 1 and high-end GNSS receivers in Chapter 3 of this deliverable, the following major technology gaps have been identified:

- Radio-Frequency (RF) front-end: to allow the implementation of an advanced receiver front end capable to match with the targeted requirements (cf. D1.2 Requirements and Receiver Specifications) the following technology gaps should be addressed in the implementation phase:
 - Find best compromise between performance and power consumption to match with the mass market requirements and select best architecture
 - Optimize the bandwidth
 - Really flexible multi frequency solution (to match with terminal requirements)
 - Linearity performances
 - Cope with Galileo signals (all solution are only Global Positioning System (GPS))
- Base band: for the baseband, we distinguish the following three topics:
 - Acquisition and tracking units:
 - Acquisition stage:
 - The optimal multi-dwell architecture, especially with respect to Multiplexed Binary Offset Carrier (MBOC)-modulated Galileo signals
 - Choice of acquisition structure, e.g., Fast Fourier Transform (FFT)-based acquisition structures, structures with partial or full code correlation, and structures that take into account or ignore the data bit transition for data channels, in terms of complexity and accuracy
 - The choice of the decision statistic in acquisition stage for Galileo signals, and, in particular, for MBOC-modulated signals
 - The best combination scheme between pilot and data channels from the acquisition point of view taking into account the trade-off between implementation complexity and performance
 - The optimal selection between the unambiguous and ambiguous acquisition methods for Galileo receivers
 - Alternative solutions to achieve high sensitivity besides increasing coherent and non-coherent integration lengths
 - Code tracking stage:
 - Significant lack of comparison studies between different proposed algorithms
 - Unified solutions, valid in a wide range of scenarios (e.g., various Carrier-to-Noise Ratios (CNRs), various multipath profiles)
 - Optimization of Multiple Gate Delay (MGD) structures in the context of MBOC modulation
 - Feasibility of Teager-Kaiser-based algorithms in the context of Galileo (and MBOC), including bandwidth limiting effects
 - Trade-off between robustness against the loss of lock and tracking accuracy for Early-Minus-Late (EML) code tracking
 - Complexity Reduced Multipath Mitigation (CRMM) algorithms for time variant channels including optimized decomposition of the observations
 - Low complexity adaptive code tracking by exploiting the new time variant CRMM algorithms
 - Carrier tracking stage:
 - The choice between Frequency Locked Loop (FLL)-only, Phase Locked Loop (PLL)-only and FLL-aided PLL loops

- The choice between single-link carrier trackers and multi-link carrier trackers (such as Kalman filters)
 - The parameters of the optimum discriminator and loop filter in carrier tracking when single-link carrier trackers are employed, i.e., individual PLL/FLL for each satellite to be tracked
 - Multi-frequency architectures
 - Code tracking in multi-frequency architectures is an open issue as the majority of the current multi-frequency receivers offer code tracking capabilities only on one frequency (L1) and for the other frequencies only carrier-phase tracking
 - The advantages of dual-frequency combinations in the context of code tracking
 - Interference mitigation
 - The performance deterioration with and without interference cancellation methods under various interference scenarios for Galileo signals, and especially, for MBOC-modulated signals
 - Differential correlation as promising approach for narrowband and wideband interference mitigation for mass-market GNSS receivers
 - Measurement of the level of narrowband interference from the received baseband signals, e.g., to use only the unaffected carrier frequency in a dual-frequency architecture
- Hybrid data fusion:
 - Hybrid data fusion with cellular communications systems
 - Tight data fusion of GNSS and communications systems
 - Joint Non-Line-Of-Sight (NLOS) detection and mitigation
 - Seamless outdoor-indoor positioning approach
 - Indoor localization systems
 - Navigation without GNSS signals – seamless outdoor-to-indoor transition
 - Pedestrian Dead Reckoning (PDR) with uncertain heading due to magnetic field distortions and gyro drift
 - Efficient detection of motion mode (static / walking / other)
 - Efficient creation of radio map
 - Efficient creation of indoor magnetic field map
 - Solving the trade-off between accuracy and computational load of position estimation algorithm
 - No filter / Extended Kalman Filter (EKF) / EKF with constraints / hidden Markov model / Particle filtering
- In addition, we identify the following other gaps, relevant for the considered mass-market segment and the work of the GRAMMAR project:
 - Wireless communications receiver positioning algorithms
 - Efficient multipath, NLOS, and interference mitigation algorithms
 - Efficient and accurate time synchronization for Orthogonal Frequency-Division Multiplexing (OFDM) receivers
 - GNSS receiver simulators
 - None of the SW receiver simulators includes the E5 Alternate BOC (AltBOC) -modulated signals
 - None of the available GNSS simulators incorporate the unambiguous acquisition or the multipath mitigation unit for tracking under multipath channels
 - None of the existing simulators is very friendly for algorithm-related developments (since sources are partially or fully encrypted) and many of them are not even available outside the units which develop them

Authors

| Partner | Name | Phone / Fax / e-mail |
|----------------|-------------------|--|
| DLR | | |
| | Armin Dammann | Phone: +49 8153 28 2871 Fax: +49 8153 28 1871 E-mail: armin.dammann@dlr.de |
| | Ingmar Groh | Phone: +49 8153 28 2805 Fax: +49 8153 28 1871 E-mail: ingmar.groh@dlr.de |
| | Christian Mensing | Phone: +49 8153 28 2878 Fax: +49 8153 28 1871 E-mail: christian.mensing@dlr.de |
| | Stephan Sand | Phone: +49 8153 28 1464 Fax: +49 8153 28 1871 E-mail: stephan.sand@dlr.de |
| TUT | | |
| | Simona Lohan | Phone: +358408490669 Fax: +35831153808 E-mail: elena-simona.lohan@tut.fi |
| | Heikki Hurskainen | Phone: +358331154562 Fax: +358331153095 E-mail: heikki.hurskainen@tut.fi |
| | Helena Leppäkoski | Phone: +358408490702 Fax: +358331154561 E-mail: helena.leppakoski@tut.fi |
| ACO | | |
| | Marco Detratti | Phone: +34942764400 Fax: + 34 942 76 44 03 E-mail: marco.detratti@acorde.com |

Table of Contents

| | |
|---|-----------|
| Executive Summary | 2 |
| Authors | 4 |
| Table of Contents | 5 |
| List of Acronyms and Abbreviations | 7 |
| 1. State-of-the-Art GNSS Receivers for Mobile Terminals Segment | 10 |
| 1.1 RF front end | 10 |
| 1.1.1 Radio architectures..... | 10 |
| 1.1.2 GNSS front ends: COTS solutions..... | 11 |
| 1.1.3 GNSS front ends: Literature review..... | 18 |
| 1.1.4 GNSS front ends: Multi band solutions | 20 |
| 1.2 Base band..... | 24 |
| 1.2.1 Acquisition and tracking units..... | 24 |
| 1.2.1.1 Acquisition structures (ambiguous/unambiguous) | 25 |
| 1.2.1.2 Code tracking structures..... | 30 |
| 1.2.1.3 Carrier tracking structures..... | 32 |
| 1.2.1.4 Different approaches for implementation of acquisition and tracking | 33 |
| 1.2.2 Interference mitigation..... | 34 |
| 1.2.2.1 Narrowband interference..... | 34 |
| 1.2.2.2 Wideband interference | 35 |
| 1.2.3 Receiver adaptation to signal conditions..... | 36 |
| 1.3 Hybrid data fusion | 36 |
| 1.3.1 Positioning with WLAN | 37 |
| 1.3.2 Positioning with cellular communications systems | 38 |
| 1.3.2.1 Positioning in 2G systems..... | 38 |
| 1.3.2.2 Positioning in 3G systems..... | 40 |
| 1.3.2.3 Positioning in beyond 3G systems..... | 41 |
| 1.3.2.4 Implementation status and integration with GNSS | 42 |
| 1.3.3 Positioning with other sensors..... | 42 |
| 1.3.4 Indoor map-matching..... | 43 |
| 1.3.5 Fingerprinting..... | 44 |
| 1.3.6 Tracking algorithms..... | 45 |
| 2. GNSS Receiver Simulators – State-of-the-Art | 47 |
| 2.1 Software GNSS receiver simulator prototypes | 47 |
| 2.2 Commercial software GNSS receiver simulators | 48 |
| 2.3 Academic software GNSS simulators..... | 49 |
| 2.3.1 A software-defined GPS and Galileo receiver | 50 |
| 2.3.2 C++ TUTGNSS | 50 |
| 3. State-of-the-Art High-End Professional GNSS Receivers | 51 |
| 3.1 Differential GNSS (DGNSS) | 51 |
| 3.2 Carrier phase tracking..... | 51 |
| 3.3 Real-time kinematic (RTK)..... | 53 |
| 3.4 Carrier smoothing..... | 53 |
| 3.5 Multi frequency receivers..... | 53 |
| 3.6 Assisted GNSS | 53 |
| 3.7 Satellite based augmentation systems | 53 |
| 3.8 RAIM..... | 54 |
| 3.9 Multipath mitigation high-end receivers..... | 54 |
| 3.9.1 Maximum likelihood based approaches: Multi-correlator based code tracking | 54 |

| | | |
|-----------|--|-----------|
| 3.9.2 | Deconvolution approaches..... | 54 |
| 3.9.3 | Sequential Bayesian estimation..... | 54 |
| 3.9.4 | Vision correlator..... | 55 |
| 3.10 | Interference mitigation..... | 56 |
| 3.11 | Dual/multi-frequency architectures..... | 57 |
| 3.12 | Professional receivers front-ends..... | 58 |
| 4. | Technology Gaps: Conclusions..... | 61 |
| 4.1 | RF front end..... | 61 |
| 4.2 | Base band..... | 61 |
| 4.2.1 | Baseband receiver architectures..... | 61 |
| 4.2.1.1 | Acquisition and tracking units..... | 61 |
| 4.2.1.2 | Multi-frequency architectures..... | 62 |
| 4.2.1.3 | Interference mitigation..... | 62 |
| 4.3 | Hybrid data fusion..... | 63 |
| 4.3.1 | Hybrid data fusion with cellular communications systems..... | 63 |
| 4.3.2 | Indoor localization systems..... | 63 |
| 4.4 | Other..... | 64 |
| 4.4.1 | Wireless communications receiver positioning algorithms..... | 64 |
| 4.4.2 | GNSS receiver simulators..... | 64 |
| 5. | References..... | 65 |

List of Acronyms and Abbreviations

| Term | Description |
|-------------|---|
| 3GPP | 3rd Generation Partnership Project |
| 3GPP2 | 3rd Generation Partnership Project 2 |
| AC | Alternating Current |
| ADC | Analog-To-Digital Converter |
| A-FLT | Advanced Forward Link Trilateration |
| AGC | Automatic Gain Control |
| A-GPS | Assisted GPS |
| AltBOC | Alternate BOC |
| ANSI | American National Standards Institute |
| AP | Access Points |
| API | Application Programming Interface |
| APME | A Posteriori Multipath Estimator |
| ASIC | Application-Specific Integrated Circuit |
| AWGN | Additive White Gaussian Noise |
| B&F | Betz and Fishman |
| BOC | Binary Offset Carrier |
| BPSK | Binary Phase-Shift Keying |
| BS | Base Station |
| BW | BandWidth |
| C/A | Coarse/Acquisition |
| CBOC | Composite Binary Offset Carrier |
| CDMA | Code Division Multiple Access |
| CMC | Code Matched Correlator |
| CMOS | Complementary Metal–Oxide–Semiconductor |
| CNR | Carrier-to-Noise Ratio |
| COTS | Commercial-Off-The-Shelf |
| CP | Calibration Point |
| CPU | Central Processing Unit |
| CRMM | Complexity Reduced Multipath Mitigation |
| DAB | Digital Audio Broadcasting |
| DC | Direct Current |
| DGPS | Differential GPS |
| DLB | Distance from LMU to BS |
| DLL | Delay Locked Loop |
| DMB | Distance from MS to BS |
| DR | Dead Reckoning |
| DVD | Digital Versatile Disc |
| DWT | Discrete Wavelet Transform |
| EGNOS | European Geostationary Navigation Overlay Service |
| EKF | Extended Kalman Filter |
| EML | Early-Minus-Late |
| E-OTD | Enhanced Observed Time Difference |
| FCC | Federal Communications Commission (FCC) |
| FD | Frequency Domain |
| FDD | Frequency-Division Duplex |
| FE | Front End |
| FFT | Fast Fourier Transform |
| FLL | Frequency Locked Loop |
| FPGA | Field-programmable Gate Array |
| GIOVE | Galileo In-Orbit Validation Element |
| GJU | Galileo Joint Undertaking |
| GLONASS | GLObal NAVigation Satellite System |
| GNSS | Global Navigation Satellite System |
| GPS | Global Positioning System |

| | |
|-------|--|
| GSM | Global System for Mobile communications |
| GTD | Geometric Time Difference |
| HRC | High Resolution Correlator |
| HSDPA | High-Speed Downlink Packet Access |
| I/Q | In-phase/Quadrature-phase |
| IC | Integrated Circuit |
| IEE | Interference Error Envelope |
| IF | Intermediate Frequency |
| IIPX | Xth-Order Intermodulation Intercept Point |
| IMU | Inertial Measurement Unit |
| INS | Inertial Navigation System |
| IPDL | Idle Period DownLink |
| IS-95 | Interim Standard 95 |
| KF | Kalman Filter |
| LMM | Leika Multipath Mitigation correlator |
| LMU | Location Measurement Unit |
| LNA | Low-Noise Amplifier |
| LO | Local Oscillator |
| LOS | Line-Of-Sight |
| LOT | Observed time from a BS to the LMU |
| LS | Least-Squares |
| LTE | Long Term Evolution |
| M&H | Martin and Heiries |
| MAC | Media Access Control |
| MBOC | Multiplexed Binary Offset Carrier |
| MCDD | Multi-Correlation Differential Detection |
| MEDLL | Multipath Estimating Delay-Lock-Loop |
| MEE | Multipath Error Envelope |
| MEMS | Micro-Electro-Mechanical System |
| MGD | Multiple Gate Delay |
| ML | Maximum Likelihood |
| MMIC | Monolithic Microwave Integrated Circuit |
| MMSE | Minimum Mean Square Error |
| MMT | Multipath Mitigation Technique |
| MOT | Observed time from a BS to the MS |
| MP | MultiPath |
| MS | Mobile Station |
| MSAS | Multi-functional Satellite Augmentation System |
| MSE | Mean Square Error |
| MT | Mobile Terminal |
| MTLL | Mean Time to Lose Lock |
| NCO | Numerically Controlled Oscillator |
| NEML | Narrow Early-Minus-Late |
| NF | Noise Figure |
| NLOS | Non-Line-Of-Sight |
| OEM | Original Equipment Manufacturer |
| OFDM | Orthogonal Frequency-Division Multiplexing |
| OTD | Observed Time Difference |
| OTDOA | Observed TDOA |
| PAC | Pulse Aperture Correlator |
| PCB | Printed Circuit Board |
| PDA | Personal Digital Assistant |
| PDF | Probability Density Function |
| PDR | Pedestrian Dead Reckoning |
| PF | Particle Filter |
| PGA | Programmable Gain Amplifier |
| PKF | Positioning Kalman Filter |
| PLL | Phase-Locked Loop |
| POCS | Projection Onto Convex Sets |

| | |
|-------|--|
| PRN | PseudoRandom Noise |
| R&D | Research and Development |
| RAIM | Receiver Autonomous Integrity Monitoring |
| RF | Radio Frequency |
| RSS | Received Signal Strengths |
| RTD | Real Time Difference |
| RTK | Real Time Kinematic |
| RTT | Round-Trip Time |
| RX | Receive |
| SAW | Surface Acoustic Wave |
| SBAS | Satellite Based Augmentation System |
| SCORR | Strobe Correlator |
| SFN | System Frame Number |
| SNR | Signal-to-Noise Ratio |
| SSC | Spectral Separation Coefficient |
| TD | Time Domain |
| TDD | Time-Division Duplex |
| TDOA | Time Difference Of Arrival |
| TK | Teager-Kaiser |
| TOA | Time of Arrival |
| TTF | Time To First Fix |
| UAL | Unsuppressed Adjacent Lobes |
| UMTS | Universal Mobile Telecommunications System |
| USB | Universal Serial Bus |
| UTC | Coordinated Universal Time |
| U-TOA | Uplink Time of Arrival |
| UTRAN | UMTS Terrestrial Radio Access Network |
| UWB | Ultra-Wide Band |
| VCO | Voltage-Controlled Oscillator |
| VEVL | Very Early-Very Late |
| VGA | Variable Gain Amplifier |
| VRS | Virtual Reference Station |
| WAAS | Wide Area Augmentation System |
| WCS | Wireless Communications System |
| WEML | Wide Early-Minus-Late |
| WLAN | Wireless Local Area Network |
| XD | Xth dimensional |
| XG | Xth Generation |

1. State-of-the-Art GNSS Receivers for Mobile Terminals Segment

In this chapter, we review start-of-the-art Global Navigation Satellite System (GNSS) receivers for the mobile terminal segment. This mass market segment was identified in D1.1 Market Definition and Core Technology Report as the major market opportunity.

1.1 RF front end

In this section we present a review of current state of the art for GNSS radio front-ends developed for its use in mass market products, to establish the starting point for the creation of our new and advanced solution. Both a Commercial-Off-The-Shelf (COTS) and literature review will be presented with the focus not only on overall performance but also on the aspects related with receiver miniaturisation, power consumption reduction/optimization, and integration with multiple platforms. Only solutions dealing with the sole front-end will be analysed (not the complete receiver). However, in the cases in which the radio information could be deduced, mention of the performance will be given for sake of completeness.

1.1.1 Radio architectures

The architectures used in nowadays wireless communications and GNSS receivers can be divided into two main categories: the direct conversion (or homodyne) architecture and the heterodyne (or Intermediate Frequency (IF) receiver or super heterodyne) architecture. All the GNSS Radio Front End (FE) considered in our analysis fall into these main categories. For this reason a brief review of the advantages and drawbacks of each of these structures are discussed in the following paragraphs based on a literature review.

The principle of a direct-conversion receiver is as follows: the incoming Radio Frequency (RF) signal is mixed with a local generated RF carrier directly to baseband, where channel selection is achieved by low pass filtering.

Alternatively, heterodyne or (multi) IF receiver can be used, where the incoming RF signal is down converted to baseband via one or several stages with band pass filters in between for the channel selection.

In what follows, a brief discussion about the advantages and disadvantages of the two architectures is given, together with solutions found in the literature to overcome the drawbacks.

Direct conversion (homodyne) architectures [WPU+08], [EWW2008]:

- Advantages
 - Easier to implement in single integrated circuit due to more simple structure (RF filtering requirements are relaxed and of course multiple IF stage are not needed) => higher integration in RF front-end
 - Only one synthesizer/Phase Locked Loop (PLL)
 - No image rejection filtering needed (no image problem)
 - Easier reconfigurability
- Disadvantages
 - Direct Current (DC) offset problem: the DC-offset can dominate the received signal and potentially saturate the receiver's Analog-To-Digital converter (ADC). If the desired signal is in the order of micro volts, but the DC-offset in the order of volts, the ADC requires a very high dynamic range. The traditional solutions to overcome the DC offsets are: the use of Alternating Current (AC) coupling and the use of idle period transmission [WPU+08]. The later solution is not suitable in the context of GNSS. The AC coupling typically works for signals with low energy component at DC (e.g., signals which are Binary Offset Carrier (BOC) or Multiplexed Binary Offset Carrier (MBOC) modulated).
 - Sensitivity to flicker noise (flicker noise or $1/f$ noise or 'pink noise' is a critical issue in GNSS receivers, because of the low received signal levels; obviously, at low frequencies, as those for homodyne architecture, this noise is more prevalent than at higher frequencies). AC coupling is also a solution to deal with flicker noise, but again, it is mostly valid for signals with little spectral density at DC.
 - In-phase/Quadrature-phase (I/Q) mismatch (i.e., imbalance in the orthogonality of the in-phase and quadrature components): they can be partly overcome by a good quality of RF circuit design.

- Even order distortion (i.e., when the second harmonic of the local oscillator mixes with the second harmonic of the desired signal translating it to baseband): they can be partly overcome by a good quality of RF circuit design.
- Oscillator leakage: this is usually not a big issue in GNSS, since it refers to the interference effects on other close-by receivers and it can be also overcome by a good quality of RF front-end.
- Additional notes
 - Analysis and simulations of homodyne architecture (in fact a very low IF architecture was used, at IF -80 kHz) in the context of GNSS L1 signals (sine BOC-modulated) in [WPU+08] showed that homodyne architecture is a promising architecture for Galileo signals.

IF down-conversion (heterodyne) architecture:

- Advantages
 - Insensitivity to flicker noise
 - Insensitivity to DC offsets
 - Lower ADC dynamic range required
- Disadvantages
 - Image rejection filtering needed
- Additional notes
 - Most used architecture in GNSS nowadays: today's RF front-end architectures for integrated Global Positioning System (GPS) receivers are designed in low-IF architecture with an intermediate frequency between 1 MHz and 4 MHz according to [EWW2008].

Traditionally, most of the wireless receivers nowadays were based on heterodyne architecture, because this kind of architecture offers a high sensitivity and provides good channel selection due to several band pass filters. However, the need for a higher degree of integration, has converted the homodyne architecture (or some of its variants) as the main choice in modern communication systems including GNSS. Tradeoffs between the two architectures above are given by the so called '**Low IF**' and '**Very Low IF**' architectures [RHS+03], where the RF signal is converted by means of a single down-conversion to an IF signal of only few MHz instead of DC. With this solution we can avoid the main disadvantages of the direct-conversion architecture. The classification into low and very low IF architectures is usually done with respect to the half of the double-sided signal bandwidth. If the signal bandwidth is denoted by B_w and the IF by f_{IF} , then

$$\begin{aligned} \text{if } \frac{B_w}{2} \leq f_{IF} < 2B_w \Rightarrow \text{low IF} \\ \text{if } f_{IF} < \frac{B_w}{2} \Rightarrow \text{very low IF} \end{aligned} \quad (1.1)$$

Low IF/Very Low IF architecture [RHS+03]:

- Advantages
 - Insensitivity to flicker noise
 - Insensitivity to DC offsets
 - No Local Oscillator (LO) leakages
- Disadvantages
 - Image rejection filtering needed. However, if IF frequency is chosen such, that the image frequency band is still "in-band" concerning the RF interference environment (e.g., L1/E1 +/- 10 MHz), the expected interference level is considerably low, and thus the requirements for the image rejection can be relaxed.
 - Highly symmetrical filters needed: this can be overcome by an on-chip differential design [RHS+03].

For these reasons the Low-IF/Very Low IF architecture is one of the most commonly used in GNSS receivers.

1.1.2 GNSS front ends: COTS solutions

Many semiconductor companies offer GNSS receiver chip or chipset solutions. However not all of them offer a separate Radio FE solution. In this section we will compare the solutions which best fits within a mass market GNSS product implementation. The attention will be focused mainly on reduced power consumption and footprint area, and simplicity of interfacing with multiple platforms. In principle, all the presented solution could be purchased in standard evaluation boards or mounted in custom developed

Printed Circuit Board (PCB) to adapt the interface with specific Baseband processing requirement (i.e., Universal Serial Bus (USB) interface for software defined receivers).

Although most devices described in scientific papers are designed with Complementary Metal–Oxide–Semiconductor (CMOS) (as will be detailed in the following section), the majority of commercial front ends use Bipolar Technology. Not all the systems are fully integrated, since in some cases Low-Noise Amplifier (LNA) is external. In all the cases 1 or 2 bit ADC are used for digitalisation. The following are the GNSS radio FE chips which have been considered as the most relevant for the mass market.

1. **SiGE-** The SE4120L is a highly-integrated GNSS radio front end Integrated Circuit (IC) offering high performance and low power operation. It features an internal LNA and supports GPS L1 and Galileo E1 signals through a selectable IF filter bandwidth (Figure 1-1). The SE4120L features a conditioned interface for software implementations of GNSS baseband signal processing. This FE solution is at present used by TUT GNSS receiver platform. Other options are available from SiGe covering only GPS band (SE4100 and SE4110) with one or two bit outputs at 4.092MHz. A preliminary product featuring a selectable input LNA for active and passive antenna selection is also available (SE4150L); however no detailed information is still available on the website. One drawback of this kind of solutions is that in general they accept only a fixed reference frequency of 16.368MHz.

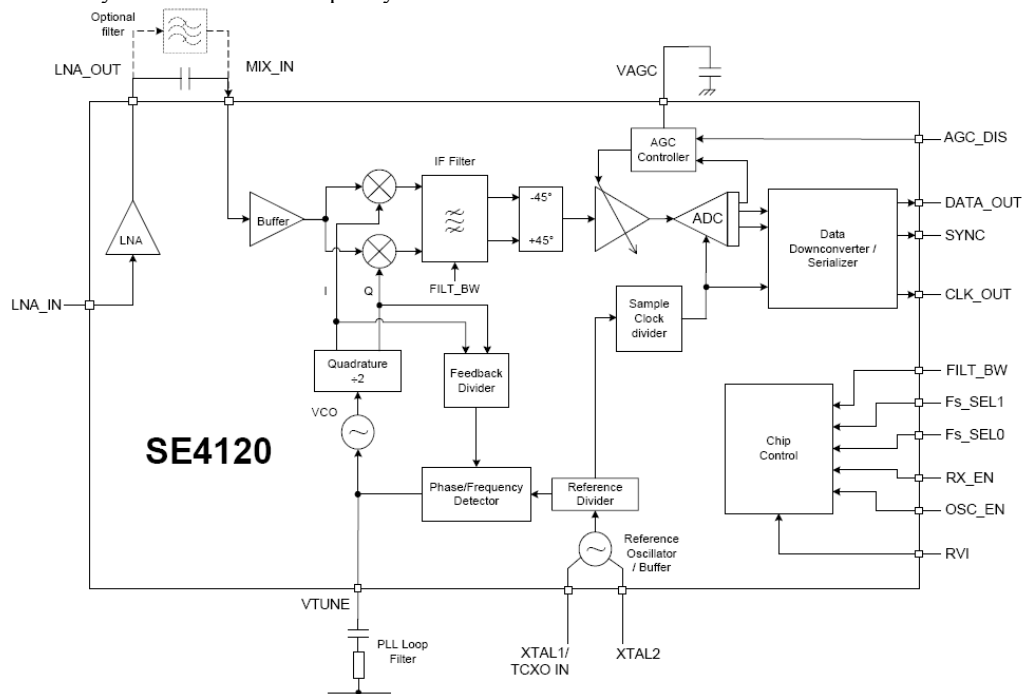

Figure 1-1: SE4120L functional block diagram (www.sige.com)

2. **NXP-** After the acquisition of Glonav in 2007, NXP started shipping the GNR1040 (Figure 1-2) as a highly-integrated, ultra- low-power, GPS RF IC operating in the L1 band. The GNR1040 was supported with flexible evaluation kits and reference designs, including a PC-based tool for controlling the device's parameters, simplifying the evaluation and integration of the device. The received signal can be quantized to one or two bits and delivered through a programmable streaming data interface to GPS baseband devices. The fractional-N frequency synthesizer architecture can use any clock reference frequency in the range of 10 to 50 MHz, enabling the support of all common reference frequencies used in mobile terminals. Now the product is offered by ST-Ericsson. It is based on a single-conversion-to-low-IF architecture, with fully integrated IF filtering.

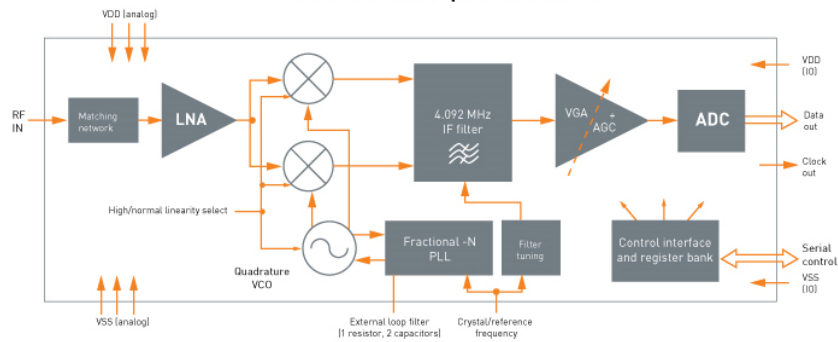

Figure 1-2: GNR1040 (www.stericsson.com)

3. **ST Microelectronics-** Latest ST GPS Front-end module is the STA5620. It has been partially developed in the frame of the FP6 project GR-POSTER and is a fully integrated RF front-end IC able to down-convert the GPS L1 signal from 1575.42 MHz to 4.092MHz. The STA5620 has a relatively broad bandwidth to cope also with GALILEO E1 signal and it is claimed to provide high-linearity to ensure excellent quality of reception in critical environments. It provides the baseband with sign, magnitude and a 16.368 MHz sampling clock, so it can work with both 1- and 2-bit GPS processors. The on-chip oscillator supports crystal frequencies from 10 MHz to 40MHz. The relatively high Noise Figure (NF), demands the use of an external LNA or active antenna in applications where high sensitivity is required.

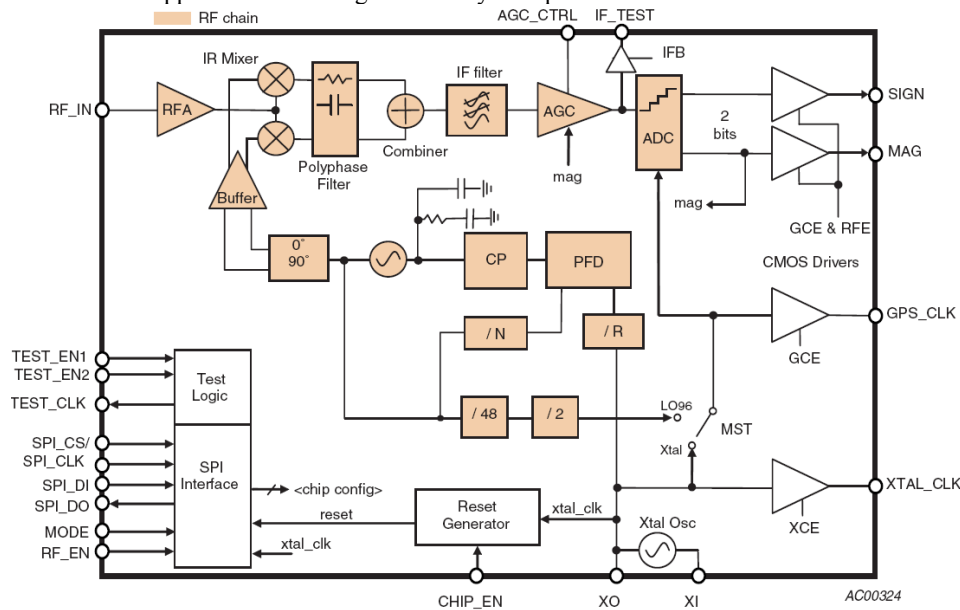

Figure 1-3: Block diagram of the ST5620 GPS/GALILEO L1/E1 front-end receiver IC (www.st.com)

4. **Atmel-** In addition to its integrated GPS solutions Atmel offers standard RF products for the implementation of custom GPS Front ends. Both ATR601 and ATR603 are single chip single IF, front-end IC designed to meet the stringent automotive requirements. The main difference is that the first solution provides 1.5 bit ADC output with internal Automatic Gain Control (AGC) while the second features 1 bit output without gain control loop (and slightly lower power consumption). In both cases an external LNA is required to enhance sensitivity (also featured by Atmel, the ATR0610). As can be noticed in Figure 1-4 the IF filter should be implemented using external SMD components.

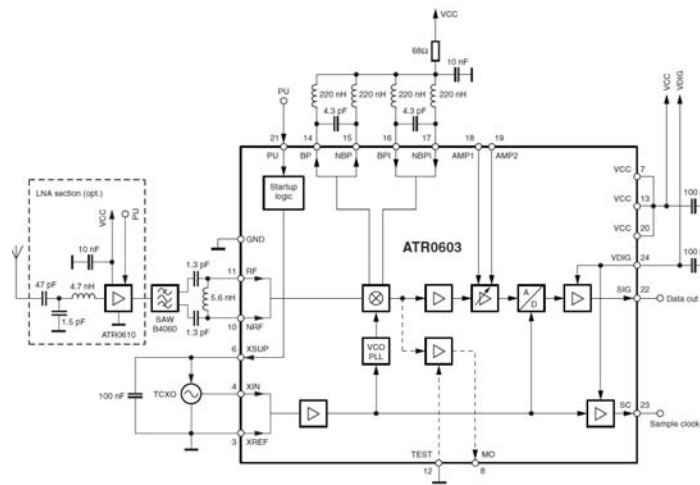

Figure 1-4: Atmel ATR0603 block diagram and suggested demo board components (www.atmel.com)

- Maxim Integrated Products**– Maxim provides multiple single-chip GPS front-end solutions (among which the MAX2741 / MAX2742 / MAX2745) which can be interfaced (via SPI) with GPS base-band ICs for in-vehicle navigation, telematics, automatic security, asset tracking, location based services and consumer electronics. Power consumptions are in the range of 30 to 50mW. An interesting product featured by maxim is the MAX2769 which is the industry's first GNSS receiver covering GPS, GLObal Navigation Satellite System (GLONASS), and Galileo navigation satellite systems on a single chip. This single-conversion, low-IF GNSS receiver is designed to provide high performance for a wide range of consumer applications, including mobile handsets. The MAX2769 incorporates on the chip the complete receiver chain, including a dual-input LNA and mixer, followed by the image-rejected filter, Programmable Gain Amplifier (PGA), Voltage-Controlled Oscillator (VCO), fractional-N frequency synthesizer, crystal oscillator, and a multibit ADC. The total cascaded noise figure of this receiver is as low as 1.4dB both the output IF and the Reference frequency can be selected according to the application. For this chip, the manufacturer provides the standard and the USB reference design as well as an evaluation board.

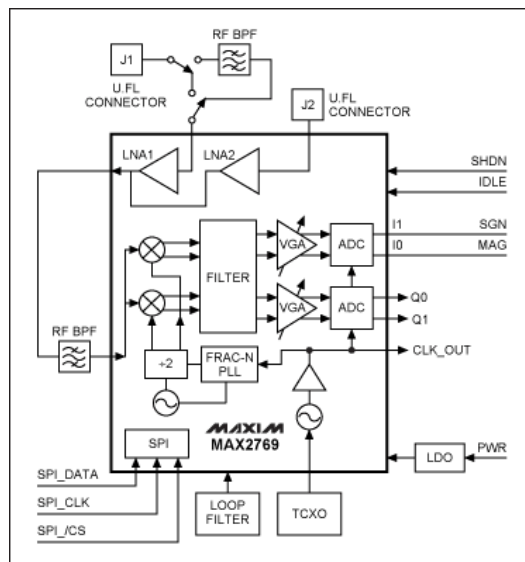

Figure 1-5: MAX2769 block diagram and external components required (www.maxim-ic.com)

6. **Sony**—Sony provides two alternative single chip radio front end solutions in an easy to use package. The CXA1951AQ is not well suited for portable GNSS devices due to the relatively high power consumption of 90mA@3V and high IF frequency of 20.46MHz, while the CXA3355AER with less than 20mW@1.8V and an IF frequency which is configurable between 1.023 and 4.092MHz, offers acceptable overall performances. The CXA3355AER IC developed as a GPS RF down converter realizes a reduction in the number of external parts by integrating an LNA, image rejection mixer, IF filter, PLL and VCO into a small package.

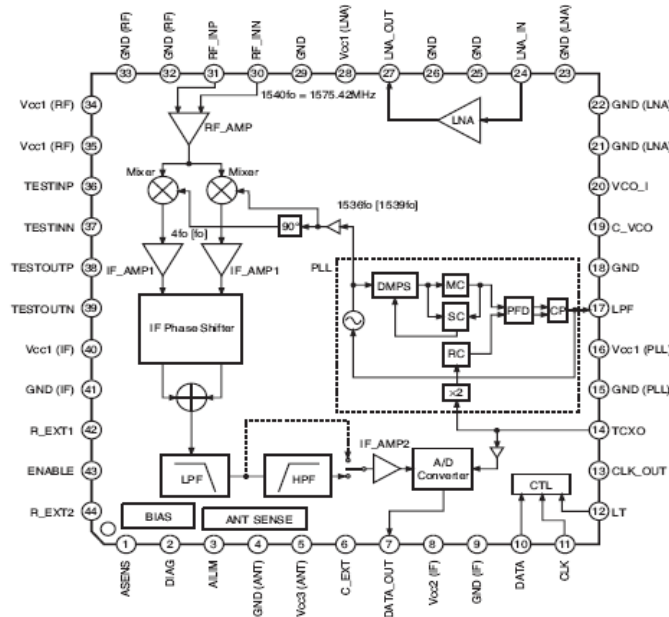

Figure 1-6: CXA3355AER functional block diagram and pin distribution (www.sony.net)

7. **NemeriX¹**- The NemeriX NJ1006A represented one of the first highly integrated, low noise RF front-end for GPS receivers targeted toward cost-sensitive portable and automotive applications. It represented one of the lowest current consumption implementation ever (6.9mA fully active). Main difference with all the previous solutions is that it implements a double-conversion super-heterodyne architecture requiring external RF and IF filters and several (22) external components. It provides 2 bit ADC output and can work with multiple reference frequencies.

¹ NemeriX no longer exists, however it has been included because their GNSS front end solutions achieved breakthrough performances.

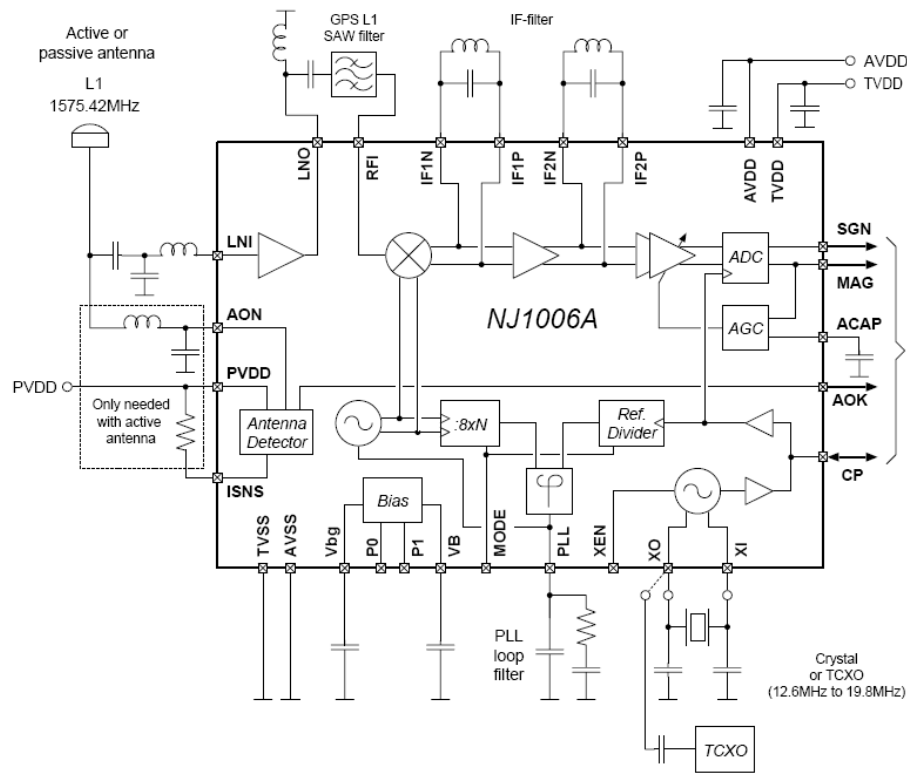

Figure 1-7: Nemerix GPS IC functional block diagram

Also Analog Devices is starting to provide GPS front end and receivers. The first GPS front-end developed by Analog will be presented during 2009 ION-GNSS (namely the SSTRF-02 chip). At the time of preparing this document no information is public, however it will be interesting to introduce its performance as an additional reference, once they will be made public.

A summary of the performance of the presented GNSS front end solutions is reported in Table 1.1. As can be noticed, for many products detailed information is not contained in the public documentation and is provided only to selected customers.

Table 1.1: State-of-the-art of commercial GNSS receiver IC

| Parameter | SiGe 4120L | NXP (Glonav) GNR1040 | ST5620 | ATMEL ATR0601 | Maxim MAX2769 | Sony CXA3355AER | Nemerix NJ1006A | Units |
|--|----------------|-------------------------|----------------|------------------|----------------------|--------------------|--------------------|--------|
| NF | 2.5 | N.A | <4.5 | 6.8 | 1.4-2.7 | ≈4 | <3 | dB |
| IF frequency | 4.092 | 4.092 | 4.092 | 96.764 | 4.092 | 1.023/4.092 | 0 | MHz |
| RX Bandwidth | 2.2-4.4 | N.A | 6 | 2 | Up to 8 | 2 | N.A. | MHz |
| P1dB (input) | -30 (only LNA) | N.A | -57 (min gain) | N.A. | -85 (mixer input) | -100 | -25(only LNA) | dBm |
| LO Phase Noise | -80@100kHz | N.A | -80@100kHz | N.A | N.A. | N.A. | -75@100kHz | dBc/Hz |
| Supported References | 16.368 | 10 to 50 | 10 to 40 | 23.104 | 8 to 44 | 13/16.368/18.414 | 13/16.368/19.2 | MHz |
| Max. Gain | N.A. | N.A | 105 | 90 | 96 | 100 | 90 | dB |
| VGA gain range | >40 | N.A. | 55 | 70 | 59 | no | 60 | dB |
| ADC/AGC | 2bit/yes | 1 or 2 bit/yes | 2bit/yes | 1.5bit/yes | 1 to 3 bit/yes | 1bit/no | 2bit/yes | --- |
| Image Rejection (typ) | 30 | N.A | 20 | N.A. | 25 | 40 | no | dB |
| IF filter | Internal | Internal | Internal | External | Internal | Int./ext. optional | External | |
| Supply Voltage | 2.7-3.6 | 1.8 | 2.56-3.3 | 2.7-3.3 | 2.7-3.3 | 1.6-2.0 | 2.2-3.6 | V |
| Power dissipation (active, typ. Supply) | 10/30 | 8.3/15 | 15/40.5 | 16.7/50 | 15-18/42.75- 51.3 | 11-13/19.8-23.4 | 6.9/21 | mA/mW |
| Power dissipation (power save) | <10u | N.A. | 1u | N.A. | 20u | 1u | 450u | A |
| Package | 4x4 24pin QFN | 4x4 24pin QFN | 5x5 32pin QFN | 4x4 24pin QFN | 5x5 28pin TQFN | 5x5 44pin VQFN | 5x5 28pin QFN | |

1.1.3 GNSS front ends: Literature review

The first integrated GPS front-end was mentioned in the scientific literature in 1992 [BEN92]. It was designed with different GaAs Monolithic Microwave Integrated Circuits (MMICs) and was capable of providing 54dB of gain, with a LNA featuring a 2.7db NF and a power consumption of “only” 1600mW. As usual, GaAs technology played an important role in the early development of this kind of devices, however as soon as Bipolar and CMOS technologies performance improved at RF frequencies, designs adopted these technologies. Thus, from 1997 on, all published GPS receiver designs have been Bipolar, CMOS or SiGe. Even if there is still a debate whether SiGe or CMOS is the most suitable for this kind of applications (SiGe performs better at pure RF but is less affordable, the apparent NF advantage of SiGe vs. CMOS is not so pronounced with the actual technology scaling, the integration advantages of pure CMOS against SiGe are evident...), we believe that the mass market need of lowering power consumption and integrating a higher number of functions within a single chip, makes the CMOS technology the most attractive solution.

A summary of the front-end solutions which have been reported in the literature in the last years (an exhaustive analysis is out of the scope of this document) which for some aspect can be considered pioneering in the state-of-the-art evolution (and which best fits with the mass market requirements targeted by the GRAMMAR project), are reported in Table 1.2. As some papers refer to the performance of the overall receiver (radio front-end plus baseband) rather than the sole front-end, the comparison between the performances has been generally extrapolated from measured and/or simulated results.

It is important to underline how all the presented solutions refer to single band L1 (in some cases E1) receivers. From the table it is clear that the most widely used architecture for GNSS radio is the low-IF with analog image rejection (even if alternative solutions demonstrate very good performance [KAD04] or are probably best suited when integrating GPS and other functionalities in the same chip [GUS07]). This consideration is valid if the IF frequency is chosen so that the image band lies within the GPS band, thus relaxing rejection requirements (the image signal is substantially white noise). In the choice of the IF frequency different trade-offs must be considered:

- IF should be high enough to easily eliminate DC offset and low frequency noise.
- Receiver IF bandwidths affects the selection of IF frequency (a wider bandwidth would probably allow some losses around DC without compromising the overall performance)
- A large IF is also beneficial to relax second-order intermodulation intercept point (IIP2) requirements. In fact, the Wireless Communications System (WCS) leakage produces second order inter-modulation products extending from DC to around 4 MHz, i.e., twice the signal bandwidth.
- To reduce power consumption in the IF section a lower frequency is preferable because the amplifiers can be designed with a lower gain–bandwidth product.

As far as the bandwidth performance, all the receivers offer quite narrow bandwidth (only [BER6] has a larger bandwidth) and this is mainly because the IF section (especially in case in which good linearity is required) contributes to a substantial amount of the overall DC power consumption.

The lack of uniformity in receiver gain has to be associated to the fact that in some cases the input LNA is included on chip ([SAHU05], [BER06], and [XU07]) while in other it is not (so additional power consumption and layout area has to be considered).

No clear common linearity requirement could be extrapolated from the different implementations, mainly because of the fact that some receivers are designed to operate as standalone circuits whereas others are optimized for the operation together with other WCSs. The GNSS system requirements become more difficult immediately when it needs to work in a mobile terminal environment. This is because GNSS system specification has internally no hard linearity and blocker requirements but looking at the operation environment of a mobile phone, the application poses a set of additional requirements to the receiver. In a mobile device, there may be many other radios operating simultaneously [GRE06].

Table 1.2: Published state-of-the-art GNSS receiver front-ends

| Parameter | [SAHU05] | [GUS07] | [VDT08] | [BER06] | [MON03] | [XU07] | [GRA06] | [KAD04] | Units |
|----------------------|------------------|-------------------|---------------------------------|---------------|------------------|---------------|------------------|-----------------------|-----------------|
| NF | 2.0 (RF+BB) | N.A | 5 ⁺ | 3.7 | 5.3 | 2 | 4.8 | 4 | dB |
| IF frequency | 4.092 | 0 | 4.092 | 20.42 | 9.45 | 0.150 | 4.092 | 1 | MHz |
| RX Bandwidth | <3 | <2.5 | 2 | 6 | 2 | 1 | 2 | <2 | MHz |
| LNA IIP3 out-of-band | 5 ⁺⁺ | -22 ^{**} | -8 ^{****} ⁺ | N.A | N.A | N.A | N.A. | N.A | dBm |
| RX IIP3 in-band | Low ² | -23 | -8 ^{****} | N.A | -28 [*] | +6 | -29 [*] | N.A | dBm |
| LO Phase Noise | -113dB@1MHz | -130@1.25MHz | -108@1MHz | -84@100kHz | -95@1MHz | -132@1MHz | -112@1MHz | -108@1MHz | dBc/Hz |
| Integrated RMS error | 2 | N.A | 1.3 | N.A | <7 | 1.62 | N.A. | N.A | deg |
| PLL Lock time | 100usec | N.A | N.A | N.A | <1msec | N.A | N.A | N.A | --- |
| Voltage Gain | >40 | 68.2 | 80 ^{****} | 103 | 81 | 80 | 92 | 110 | dB |
| ADC/AGC | 4bit/yes | ΣΔ1bit/no | 2bit/yes | 1bit/no | 2bit/yes | No/no | 1bit/no | 1bit/no | --- |
| Supply Voltage | 1.4 | 1.2 | 1.8 | 3.3 | 1.8 | 1.8 | 1.8 | 1.8 | V |
| Power dissipation | 60/84 (RF+BB) | 41/50 | 11.4/20.5 | 23/76 | 20/36 | 36.7/66 | 17/30 | 15/27 | mA/mW |
| Technology | 90nm CMOS | 130nm CMOS | 180nm SiGe | 350nm SiGe | 180nm CMOS | 180nm CMOS | 180nm CMOS | 180nm CMOS | ---- |
| Area | 12.8 (RF+BB) | <6.6 | 3.24 | 8.4 | 3.6 | N.A | 4.1 | 4.6 | mm ² |
| Architecture | Low-IF | Zero-IF | Low-IF | Low-IF | Low-IF | Low-IF | Low-IF | Double- Conversion | --- |
| Image Rejection | 18dB | No | >20dB | No | 30 | 20 | 30 | 40 | ---- |

* Input P1dB LNA+MIX

++ Complete Receiver at PCS

*** 1dB desensitization at 1.9GHz

**** extrapolated

+ Simulated

** 1dB NF desensitization at 725MHz offset

+++ offset input P1dB (VGA min gain)

² In-band jammers which are 14dB higher than GPS signal level are mentioned

From the point of view of the layout area, a target for the radio front end could be in the order of 4mm^2 , even if this requirement should not be considered as too strict, because most of the commercially available packages with sufficient pin number (a 24-32 pin solution could be the target) have a minimum internal area which is usually greater than 5mm^2 .

As far as frequency synthesizer specifications are concerned, no stringent requirements exist in terms of spurious levels and switch-on time for the applications when only one GNSS frequency is considered. Regarding the VCO phase noise, a value in the order of $-85\text{dBc}/\text{Hz}@100\text{KHz}$ offset and $-105\text{dBc}@1\text{MHz}$ offset, is generally sufficient to guarantee acceptable performances. In the two cited references in which phase noise performance are much better than these requirements ([GUS07] and [XU07]), VCO phase noise specifications are determined by the fact that the same VCO is used for both GNSS and cellular applications.

Finally a couple of interesting considerations about the ADC implementation and the technology used in the majority of the receivers should be done. It is clear that a high number of bits in the ADC are not required, because the excess in complexity and power consumption does not pay the increase of performance. Also from a technological point of view it appears clear that using a much scaled technology does not pay in terms of power consumption, layout area saving and linearity. In this sense, it can be deduced that probably the best compromise between RF performance, layout area optimization, power consumption and cost for the radio front end will be offered by a mature 180nm CMOS technology.

1.1.4 GNSS front ends: Multi band solutions

As discussed in [GRA01], it is likely that in the future, in order to obtain enhanced receiver performance in harsh environments like indoor and urban canyons, where strong multipath is present and acquisition and tracking could benefit from the use of a second frequency band (in addition to L1-E1), dual/multi frequency implementation will represent the solution to some problems of single band GNSS receivers. At present there is no commercial solution addressing a multi-band GNSS radio, and it is still difficult to predict if multi-frequency GNSS receivers will reach the consumer mass market or will be restricted to high-end applications (scientific projects, survey, timing, ...), however some results presented in literature show promising RF performances (comparable with present mass market implementations), which suggest that it would be possible to embed such advanced solutions also in mass market product like a cellular phone. In this section we will detail only published results not related with the dual-band Radio implementation which has been carried out in the frame of the FP6 GREAT project, because information on its performance will be used as the bases for further developments within GRAMMAR and its performance will be briefly summarized in Section 4.1.

Most multi-frequency front-ends (generally used in professional high precision receivers) are prototypes realized with discrete components. Multiple single-frequency front-ends replicate a single frequency front-end for each added frequency. Usually the design is based on a front-end which has been demonstrated in the past and it is thus a secure way to proceed. The first dual-band GPS receiver chip was introduced in literature in 2005 [KO05]. The paper describes the design and implementation of a single chip L1/L2 dual-band GPS receiver in a 0.18- μm CMOS process that can receive both L1 and L2-band signals because of the good tracking performances of the L2 C/S signal in multipath environments.

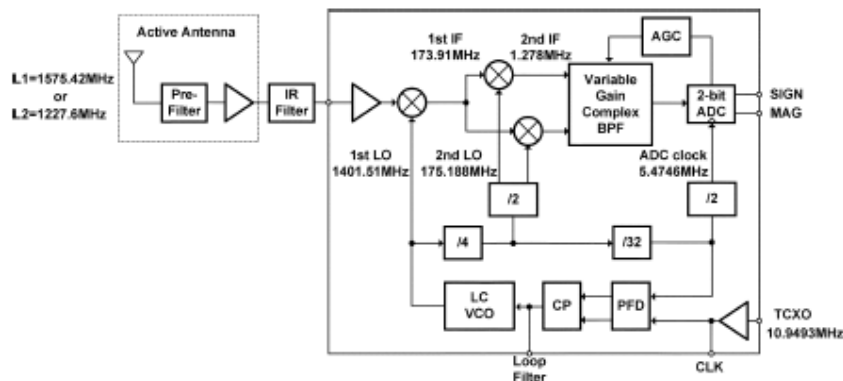

Figure 1-8: Dual band double conversion architecture [KO05]

A dual-conversion with a final low-IF architecture is presented (Figure 1-8) based on the following reasons:

- o Both L1 and L2 frequencies can be translated into the same first IF frequency with a LO centred between the two frequencies.
- o This choice of the first IF (173.91MHz) causes the first IF image signal to lie within the alternate GPS band. Thus, the required image rejection for first the IF is quite low (we need only to reject thermal noise).
- o With a low second IF (1.278MHz), the second IF image signal also lies within its own GPS band. Thus, the required image rejection for the second IF is also quite low.
- o All of the building blocks are identical for both band operations
- o All LO signals for L1 and L2 can be coherently generated from a single PLL

Fundamentally, with this solution and a single mixer and frequency synthesizer, the two signals can be down-converted to a common intermediate frequency as they are taken image one of each other.

The presented solution would require an external LNA to obtain acceptable sensitivity performance. The chip could be used to implement a switching architecture (with external LNA and filter), a single band L1 or L2 receiver or simultaneous reception using two different chips. No simultaneous acquisition would be possible with a single chip, because once down converted to the common IF, the information required to separate both signals is lost. The circuit show promising results like a very small layout area (2.6mm) and reduced power consumption (less than 20mW). Major drawbacks associated with this solution is that the receiving bandwidth is extremely narrow (<2MHz) and will not be sufficient for the reception of modernized GNSS signals and the in band ripple of 3dB seems a bit too high. Moreover it requires an external LNA (which imply additional power consumption to be taken into account) and the number of pins (44) would require quite a large package which makes not too relevant the reduced chip dimensions. The authors of this paper have been asked for the development status of this product (as they are with an IC design company). However the fact that no answer has been obtained, that in the company's web page no mention of this solution is made and that the only single band solution presents consume much more power (in the order of 50mW), let us think that some additional problem should be associated with this solution.

An alternative approach is presented in [CHA05]. In this solution the overlapping of L1 and L2 after the first simple (i.e. not quadrature) down conversion is solved considering that the GPS bands are dominated by thermal noise and don't contain any strong interferer. Also, the GPS civil bands only occupy 2MHz of the 20MHz allocated to the GPS military bands. Consequently, the first LO can be shifted from the midpoint between the two frequencies while keeping the images in the GPS bands (Figure 1-9).

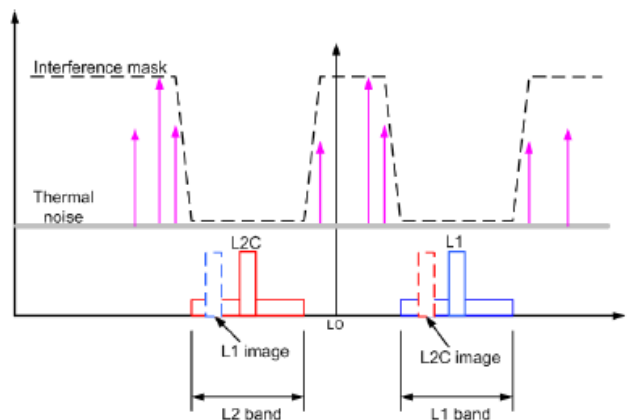

Figure 1-9: Image frequencies for L1 and L2CS if first LO is shifted from the centre between the two frequencies [CHA05]

Then, to down convert this signals to baseband, it is used a modified Weaver architecture. Since the two second IFs are different for L1 and L2CS, a supplementary set of additional digital mixers is required. The resulting architecture is presented in Figure 1-10. This solution has not been implemented and only simulated at a system level. No published results have been made public up to today (first half of 2009). It claims it will be possible to obtain the same power consumption as in [KO05], however the need for a

second ADC make this assumption not feasible. Moreover it is not clear how it could be implemented the gain control in the analog domain when the processing is carried out simultaneously on signals with different gains. Another problem is the lack of flexibility due to the multiple constraints on LO frequencies and the need for different frequencies for the last digital down conversion. It does not seem that this solution could be really feasible from an implementation point of view, and we believe that heterodyne-like architectures like the ones presented in these papers are not well suited for tight integration levels required for personal handset.

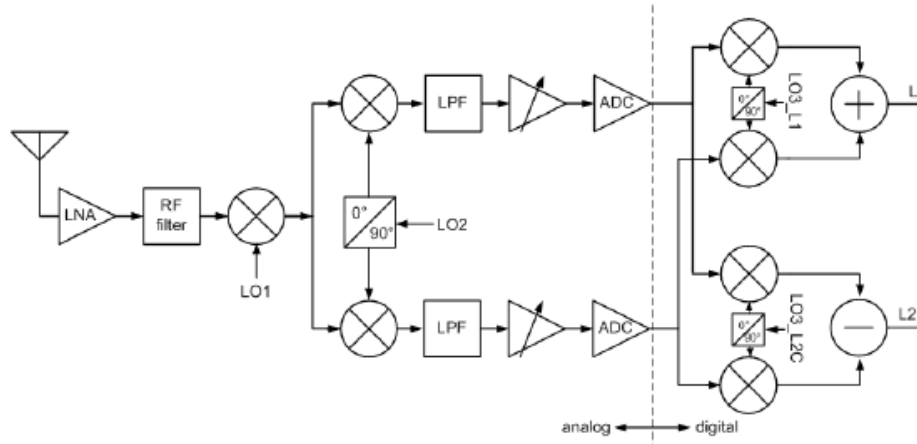

Figure 1-10: Modified Weaver-Heterodyne architecture presented in [CHA05]

A last publication relative to the integration of multi-band capabilities in a GPS receiver IC has been presented in [ABD07] and [ESE06]. Two separate chips (one for signal conditioning and one for frequency synthesis) are required and described separately (Figure 1-11). The complete analog signal path is integrated, including dual-band front-ends for L1 and L2 GPS signals, variable gain amplifier with a complex filter, limiting amplifiers, a 2-bit (ADC) and AGC loop. All local oscillator signals are generated by separate chips which include a programmable integer synthesizer, the carrier recovery and code tracking unit in reality is outside the chip and implemented in a Field-Programmable Gate Array (FPGA). The topology used is a low-IF (4.092MHz).

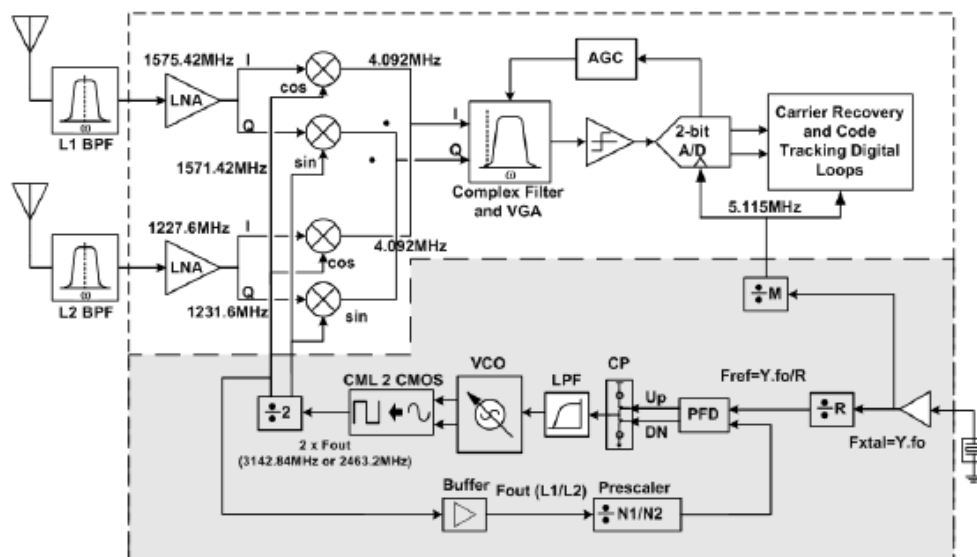

Figure 1-11: Dual band GPS receiver architecture as presented in [ABD07] and [ESE06]

This paper claims the lowest power consumption (12mW for the receiver and 4mW for the synthesizer) however several errors have been found in the paper and it is not clear at all how (and if) this circuits can

work. All the presented results are based only on high level simulations and no trace of implementation results have been found up to now. Regarding the Input LNA it is stated that it consumes 4mA, but it is not specified if it refers to one or to the two LNAs (more likely referred to only one). The same occurs with the mixer. It is stated that one consumes 5mA, so if both are working the power consumption would raise to 10mA. So it is supposed that this dual frequency architecture is a sort of switching architecture in which only one set of LNA-MIXER section can be active at the same time. If not so, it is not clear how to distinguish L1 and L2 signals when they are both down converted at the common IF of 4.092MHz. Additional doubt is regarding the IQ filtering and ADC conversion. Only one ADC is mentioned (and no mention to its DC power consumption), while in principle two ADC would be required to process complex I/Q signals. Also the synthesizer consumption is not explicitly detailed in [ESE06] and it seems more obtained from system level assumptions.

A separate mention requires the patent on multi frequency GNSS receiver issued in 2007 by Nemerix [NEM07]. The simplified Block diagram is presented in Figure 1-12.

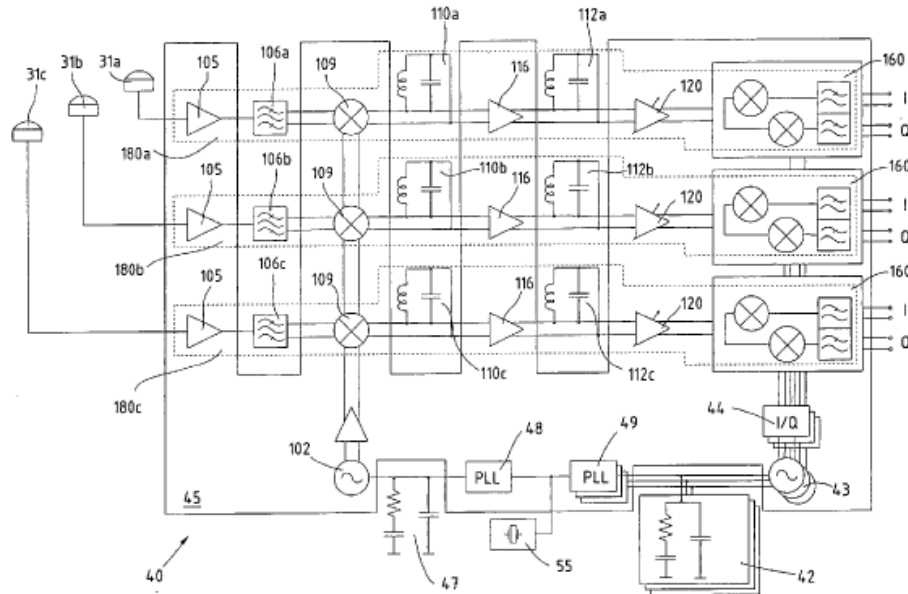

Figure 1-12: Multi-band GNSS receiver [NEM07]

This architecture is substantially based on the repetition of the architecture used by Nemerix in its single band front end. It is based on a Super-heterodyne architecture with multiple RF and IF external filters. This approach does not suggest any particular configuration nor novel solution, it is simply the repetition of a separate reception chain for each frequency band introduced in a single chip (only the concept is presented, no news about its implementation has been found, especially after Nemerix's bankrupt). Sincerely it does not seem a too promising architecture for achieving a high level of integration and low power consumption. No detailed information on the overall performance of a practical implementation of this solution can be found (and we think could not be expected) in the market.

On a similar principle is based the dual band GNSS receiver offered as an IP block from MIPS technologies offered through the Synopsis Service (CI10612tg, Figure 1-13). The CI10612tg is an integrated low-noise multi-band RF front-end for Galileo reception, with two down conversion chains. It allows simultaneous reception of L1 with E5a/b, E6 or GPS L2 bands. The architecture for L1 is sliding IF. The high resolution fractional N frequency synthesizer has a VCO running at 1.400 GHz which is directly used for the RF LO. The IF mixer LO is derived from the frequency synthesizer after the "by 8" divider. The input signal for L1 is centred on the L1 GPS frequency (1.57542 GHz). If using the embedded LNA, this signal is amplified by the single-ended LNA and then fed to an external Surface Acoustic Wave (SAW) filter with 50Ohm input impedance. The SAW filter has a 100Ohm differential output. The architecture for the second chain is conventional heterodyne. The RF mixer LO is provided by the same frequency synthesizer used for L1 band, whereas the IF LO is provided by an independent low frequency PLL (121MHz to 224MHz). The second chain input signal frequency range is 1.164-1.300 GHz. The only specified performance are related to the power consumptions at 1.8V supply voltage: L1

band; 22mA, L2 band: 17.5mA; two bands: 36mA. The power consumption does not seem too low, even considering that no information is provided on the receiver bandwidth.

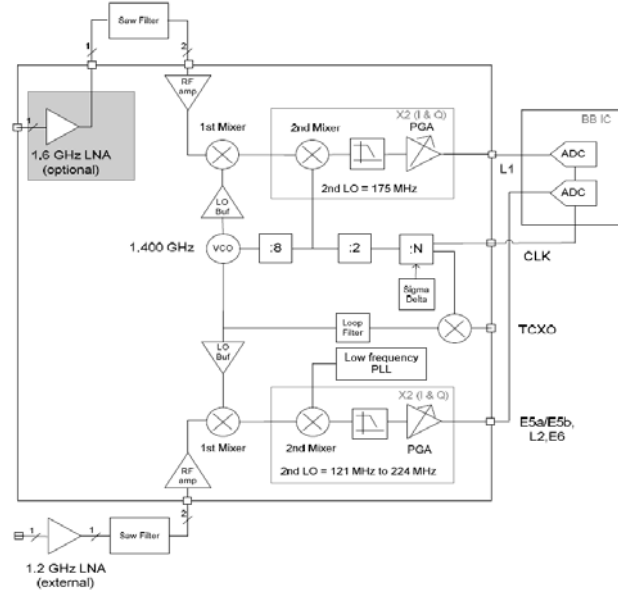

Figure 1-13: Functional diagram of the CI10612g

1.2 Base band

Regarding the passage from the front-end to baseband, according to [EWW08], an ADC resolution of 3-bits seems to be sufficient to decrease the sensitivity of the receiver not too much and on the other hand keep the complexity of the digital baseband low. With 1-bit ADC, there are about 1.8 dB losses (i.e., 1.8 dB higher noise figure) compared to 3-bit ADC. The analysis in [EWW08] was done based on homodyne Galileo/GPS L1-band architecture.

The number of ADC bits will be again addressed in Section 2.1, when discussing the different software receiver simulators existing in academic and commercial units.

1.2.1 Acquisition and tracking units

From the point of view of the acquisition unit, a fast acquisition with a low cost implementation is the target to be achieved. Accuracy of the order of 1 chip or slightly below 1 chip should be enough in the acquisition process. Also, a high sensitivity (i.e., acquiring the signal at low Carrier-to-Noise Ratios (CNRs)) is also desirable. The structures of choice available for the acquisition unit are enumerated below and discussed in more detail in Section 1.2.1.1:

- Single-dwell versus double (or multiple)-dwell architectures
- Time correlation versus Fast Fourier Transform (FFT) based correlation
- Choice of the decision variable in the acquisition unit
- Unambiguous versus ambiguous methods
- Type of combining the pilot and data channels for acquisition purposes

From the point of view of the tracking unit, the important criteria are: a large Mean Time to Lose Lock (MTLL), good behaviour (e.g., stability) in the presence of noise, ability to deal with multipaths, and, of course, low complexity. Operating with a low number of correlators in the tracking stage is important for mass-market applications, where cost issues are of utmost importance. Therefore, we will only consider the structures with low number of correlators as multipath mitigation structures likely to be useful in mass-market applications. They will be discussed in Section 1.2.1.2. We further discuss multipath mitigation delay trackers, where low complexity is not of utmost importance. Also, one issue to consider regarding the delay tracking unit architecture is whether the estimation is to be done in one-shot (i.e., the so-called open loop architecture), or in a feedback manner (i.e., closed-loop architecture).

1.2.1.1 Acquisition structures (ambiguous/unambiguous)

1.2.1.1.1 Single-dwell versus double-dwell architecture

The choice of the multiple-dwell strategy is not so well-documented in the literature. Generally, double-dwell or three-dwell structures are preferred [KL03], [KDH+06]. However, very little comparison studies with single-dwell structures, especially aiming at the same performance (i.e., same global detection and false alarm probabilities) can be found in the literature [LBR04]. To recall, the block diagram of a multiple-dwell architecture is shown in Figure 1-14. Here, only one dwell stage is shown among all the possible K dwell stages ($k=1, 2, \dots, K$) [LBR04]. In each stage, one or several time-frequency correlations are performed (depending on whether we have serial, hybrid or parallel search), then they are coherently and non-coherently integrated, and then a decision statistic is formed and compared with a threshold. If the decision statistic is higher than the threshold, we go to the next dwell stage and we repeat the procedure. The coherent and non-coherent integration intervals are different (increasing) from one dwell stage to another. The final decision regarding the acquisition is taken in the final (K -th) dwell stage.

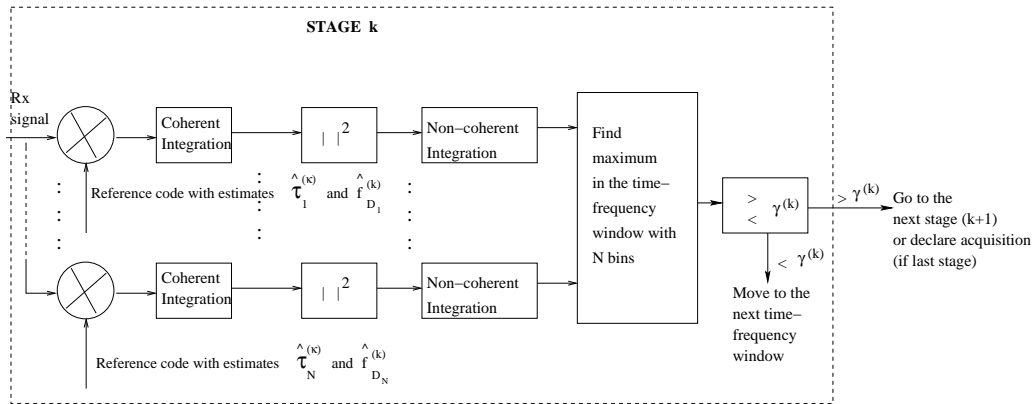

Figure 1-14: Multiple-dwell architecture for acquisition - block diagram [LBR04].

The main idea of a multiple-dwell architecture is to speed the decision in the first dwell stage (or stages) by allowing a higher false alarm probability (and high detection probability), and then going to subsequent dwells with lower false alarm probabilities. The overall false alarm and detection probabilities will be the product between each dwell-stages probability. Thus, by selecting properly the integration times at each dwell, we can achieve (in theory) faster acquisition.

However, as shown in [LBR04], double-dwell structures are not always better than single-dwell architectures; in fact, under the assumption of reasonably low penalty factors (i.e., those associated with a return from a false alarm state) and reasonably high time-bin steps, the single-dwell architectures are better.

We remark that, sometimes, the double-dwell architectures are referred to as detection-verification or 2-stage acquisition [KDH+06].

1.2.1.1.2 Time correlation versus FFT-based correlation

The correlation between the incoming signal and the reference code can be done either in Time Domain (TD) or in Frequency Domain (FD). In TD methods, a correlation value is computed for each code phase, usually in half-chip increments, until the full length of the PseudoRandom Noise (PRN) code is covered. The FD correlators employ FFT in order to search all the possible code phases in only one step. In both approaches, the procedure is repeated for all the possible Doppler shifts.

A comparison between time-domain and FFT-based correlations for Galileo SinBOC(1,1)-modulated signals can be found in [LLR04]. It was shown in [LLR04] that FFT-based correlations are the best choice in the acquisition stage in terms of complexity. Moreover, FFT-based correlators are more suited to be used with hybrid search acquisition (TD correlations require extra memory tables).

Regarding the FFT-based correlation structures, there are several acquisition methods proposed in the literature:

- Classical FFT-based acquisition, also called sometimes $N+N$ ms acquisition method [CME+07]: here, we select $2N$ ms of signal in a buffer (First In First Out) and N ms of local (reference) code $+N$ ms of zeros; N is equal to the code epoch length in ms (e.g., $N=1$ for GPS C/A, $N=4$ for Galileo

E1 OS, etc), then we perform the FFT correlation between the 2 blocks of $2N$ ms, and as the result we keep only the first N ms of the correlation. An illustration of this principle for $N=1$ is shown in Figure 1-14 [CME+07]. Alternatively, the zero-padding could be omitted. Comparisons between the traditional FFT structures (with and without zero padding) are hard to be found in the literature [LLR04].

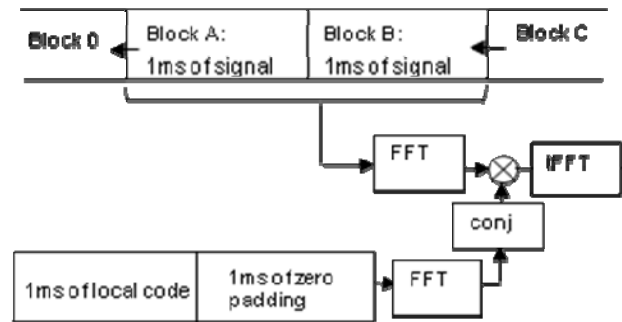

Figure 1-15: Classical FFT-based acquisition [CME+07]

- Half-bit acquisition method, originally proposed in [PSI01]: this method is based on two sets of $N_{\text{data}}/2$ ms of signal coherently integrated, where N_{data} is the data bit length in ms (e.g., $N_{\text{data}}=20$ in GPS and $N_{\text{data}}=4$ in Galileo E1 OS). The division in two sets is done in order to avoid data bit transitions: since the data bit length is N_{data} ms, there will be no bit transition in at least of the two segments of length $N_{\text{data}}/2$ ms. The decision will be taken based on the highest correlation output between the two segments. This technique allows long coherent integration without the knowledge of the data bit integration time, at the expense of a heavy computational cost.
- Double Block Zero Padding Method [CME+07]: this method uses correlation over less than N ms of signal, N being the code epoch length. This allows for a decreased complexity (faster acquisition time), at the expense of performance deterioration. A patent of an extension of this method, allowing longer integration of correlation has been applied [HGa08].

1.2.1.1.3 Decision variable choice

The most typical acquisition methods in GNSS receivers are those based on hybrid search. The serial search method is too time consuming, especially for Galileo long codes of 4092 chips or more, and the fully parallel approach requires a tremendous hardware complexity (triggered by the number of parallel correlators). The hybrid-search case is the most general case; it allows achieving a proper balance between the acquisition speed and hardware complexity and it covers the serial- and parallel-search situations as two extreme cases, as explained in [LLR05]. The acquisition process can be seen as a two-step process: in the first step, a decision variable or a test statistic is built (based on the correlation between the received signal and a locally generated reference code), and then, a decision threshold is chosen in such a way to attain a given detection or false alarm probability. The choice of the test statistic is not well-documented in the literature in the context of GNSS signals. A ratio-of-peak variable was proposed in [PLR05], as the best choice among 3 studied test statistics.

An adaptive choice of the decision variable in the context of GPS signals has been recently discussed in [CJ08].

1.2.1.1.4 Ambiguous versus unambiguous acquisition of MBOC signals

The typical acquisition unit correlates the incoming signal with the reference, modulated code (either sine BOC(1,1) or MBOC modulation can be used). This traditional correlation is ‘ambiguous’, in the sense that there are some secondary local peaks, besides the global correlation peak, which are less than ± 1 chip apart from the global peak. Additionally, there are some local minima within the ± 1 chip interval around the global peak, which make the acquisition process more time-consuming (or more complex). The ambiguous correlation is illustrated in Figure 1-16.

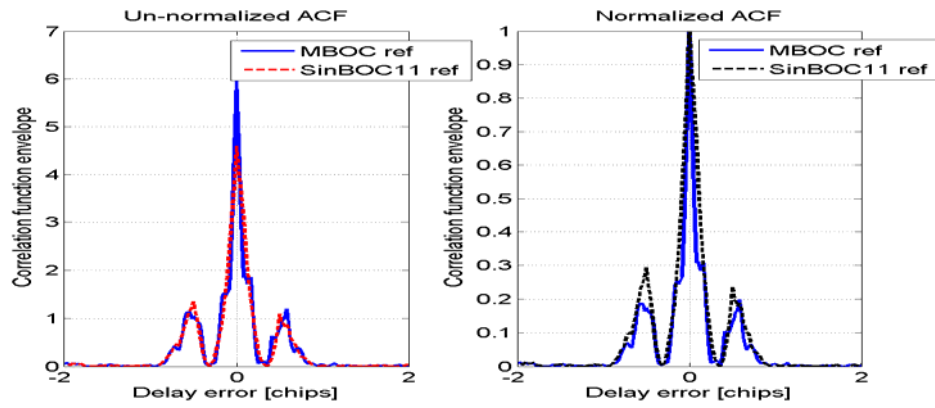

Figure 1-16: Examples of ambiguous correlation functions with MBOC and sine BOC(1,1) reference signals. Left: un-normalized values; right: normalized values. Single-path channel, CNR=40 dB-Hz.

In order to deal with the ambiguities of the traditional BOC correlation, several unambiguous methods have been proposed in the literature. Their underlying idea is to convert, through some filtering or other transforms, the ambiguous correlation-shape into a ‘Binary Phase-Shift Keying (BPSK)-like’ shape, without additional gaps and side peaks around the maximum peak. A study of the unambiguous acquisition methods for BOC-modulated Code Division Multiple Access (CDMA) signals can be found in [LBR08]. They can be divided into the following algorithms:

1. *Betz&Fishman (B&F)* algorithm or sideband correlation [BET99], [FB00], [MAT05]: in this method, the spectral sidebands of the signal (respectively of the code) are processed individually. The block diagram of the dual-sideband B&F method is shown in Figure 1-17. The single-sideband B&F method keeps only one of the bands (either upper or lower) when forming the decision statistic. Both the received signal and the reference code (assumed to be real) are filtered and their upper (or lower) bands are correlated, then added non-coherently. This is the most encountered unambiguous acquisition method.

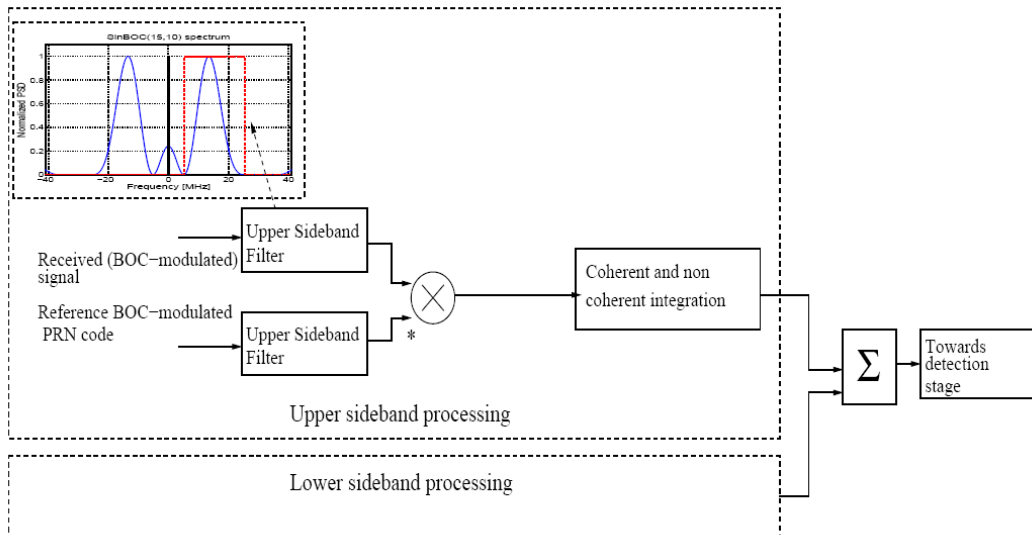

Figure 1-17: Block diagram of Betz and Fishman (B&F) unambiguous acquisition method (here, the frequency spectrum is shown for sine BOC(15,10) [LBR08]).

2. *Martin&Heiries (M&H)* approach or BPSK-like techniques [MLG+03], [HOR+04]: the block diagram is shown in Figure 1-18. Here both main side lobes of the received signal are filtered and correlated with a shifted version of the PRN reference code, up-sampled to the same rate as the incoming signal. The drawback for this method is that it is not working properly for odd

BOC modulation orders. We recall that N_B is the BOC modulation order is defined as twice the ratio between the subcarrier frequency f_{sc} and the chip rate f_c i.e.,

$$N_B = \frac{2f_{sc}}{f_c} \quad (1-2)$$

For example, for sine BOC(1,1), $N_B = 2$, and for MBOC variants $N_B = 12$ [LLR06], [LR07]. However, since for the signals of interest (i.e., Galileo signals), BOC modulation order is always even, the above-mentioned drawback can be discarded.

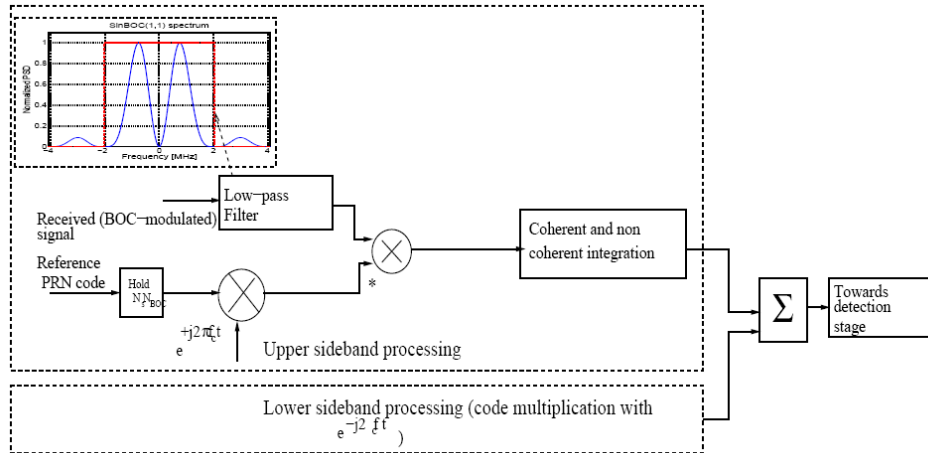

Figure 1-18: Block diagram of Martin&Heiries (M&H) unambiguous acquisition method (here, the frequency spectrum is shown for sine BOC(1,1) [LBR08]).

3. *Modified B&F method*: Its principle is shown in Figure 1-19, the upper signal spectrum (a). The received signal is shifted with $\pm a f_c$ in frequency domain, then the main lobe is selected (either upper or lower), and the resulting signal is correlated with the reference PRN code (brought at the signal rate). The shifting factor a depends on the BOC modulation order [LBR08]. For sine BOC(1,1) and MBOC signals, $a = 1$.
4. *Modified M&H method*: Its principle is shown in Figure 1-19, the middle signal spectrum (b). The difference with the modified B&F approach is that now we select both main lobes of the incoming signal (not only one of them). The performance of the modified M&H method is exactly the same as that of M&H method, but it has a lower complexity, as shown in [LBR08].
5. *Unsuppressed Adjacent Lobes (UAL) method*: its principle is shown in Figure 1-19, the middle signal spectrum (c). In here, the filtering part is removed completely, in order to decrease the implementation complexity. It has slightly worse performance than the modified B&F and modified M&H approaches, but it offers lower complexity [LBR08].

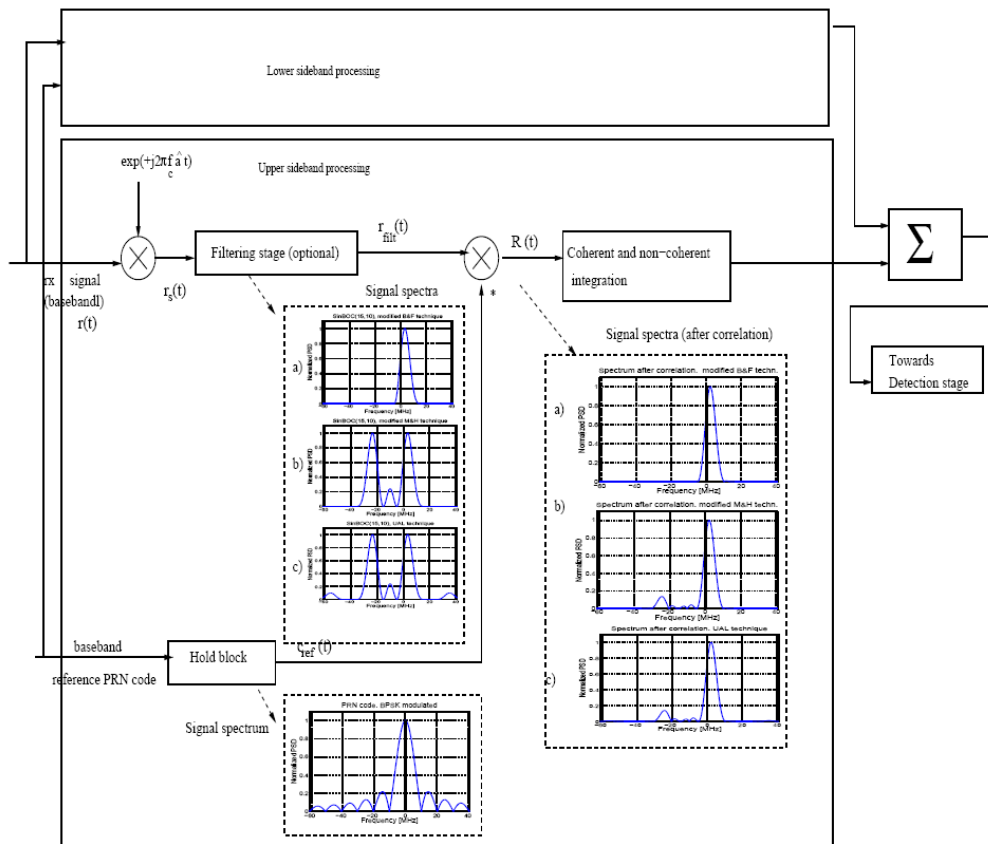

Figure 1-19: Block diagram of unambiguous acquisition methods of lower complexity than B&F method (here, the frequency spectrum is shown for sine BOC(15,10) [LBR08]). a) Modified B&F, b) Modified M&H, c) UAL.

Recent studies on unambiguous approaches on MBOC signals showed that unambiguous methods can offer up to 4 dB CNR enhancements in the acquisition process [SL09],[SAM09]. The best performance is achieved with B&F method, which has also the highest complexity, while the lowest complexity unambiguous method, namely UAL, offers up to about 2 dB CNR enhancements (in dual-sideband configuration, single path static channel and serial searches) [SAM09]. The behaviour of unambiguous acquisition approaches in the presence of multipaths and fading has been only studied for some limited scenarios in [SAM09]. According to the limited cases studied in [SAM09], the advantage of unambiguous methods over the ambiguous acquisition seems to hold also in fading multipath channels.

The main question is whether the extra complexity introduced by the additional processing in unambiguous acquisition approaches is justified by the few dB enhancements in performance. Among the above-mentioned unambiguous approaches, the UAL seems the most suitable for mass-market applications, due to its lowest complexity among the unambiguous methods.

1.2.1.1.5 Pilot and data channel combining

In Galileo, pilot and data channels coexist on E1, E6 and E5 bands. In E1, the pilot and data channels are code and power multiplexed (data channel uses Composite Binary Offset Carrier (CBOC) (+) modulation, while pilot channel uses CBOC(-) modulation and they are then subtracted); the power sharing is 50%-50% between data and pilots. In E5 band the pilots and data are quadrature-phase multiplexed (i.e., the data signal is sent on I channel and the pilot signal is sent on Q channel), and in E6 band we also have code and power multiplexing between data and pilots (i.e., different ranging codes are used to spread the data and pilot channels, respectively and then the two are subtracted) [SIS-ICD08].

Very few research papers addressed the issue of how to combine the data and pilot channels in forming the acquisition variable (or test statistic). The general understanding is that the correlation outputs from the two channels (data and pilot) can be squared, non-coherently integrated and then summed together in order to form the decision variable (this is the so-called non-coherent data-pilot combining) [BP08].

Coherent combining methods have been proposed in [BP08], [MAT05], and [YHT04] for both E1 and E5 signals. The main idea of coherent combining methods is to add, respectively subtract the pilot and data channels and form two decision variables Z_1 and Z_2 , and then to form a decision variable, based, for example, on the maximum between the two Z_i outputs. It was shown in [BP08], that the coherent combining scheme slightly outperforms the non-coherent combining, but only if CNR is high enough (e.g., higher than 35 dB-Hz). At low CNRs, the two methods give the same performance. However, detailed comparisons between coherent and non-coherent combining are hard to be found in the literature.

1.2.1.1.6 High-sensitivity receivers

The typical way to increase the operational range of GNSS receiver to lower CNRs is to increase the coherent and non-coherent integration times. For a coherent integration time of N_c ms and a non-coherent integration time of N_{nc} blocks, the CNR gain is [MAT05]

$$CNR_{gain} = 10 \log_{10} (N_c \sqrt{N_{nc}}) \quad (1-3)$$

That is, a coherent integration of 4 ms, followed by subsequent non-coherent integration of 8 results would enhance the CNR with about 10.5 dB (we remark that the non-coherent integration does not narrow the noise bandwidth, thus the non-coherent gain is only half of the coherent gain).

When increasing the coherent integration time, the dynamics of the receiver should also be taken into account, since long integration is vulnerable to Doppler shift. Also, the carrier tracking is limited by the navigation data symbol interval, which for many Galileo signals is only 4 ms.

1.2.1.2 Code tracking structures

1.2.1.2.1 Classical tracking structures

Traditionally, the multipath delay estimation block is implemented via a feedback loop. The most common feedback structures for the delay estimation are the so-called Delay Locked Loops (DLLs), and, more specifically, the Wide Early-Minus-Late (WEML) and the Narrow Early-Minus-Late (NEML) structures. In WEML [BBC+00], the spacing between the early and late correlator gates is 1 chip; in NEML [DFF92], [IE03], [MB99] also called narrow correlator, the spacing between the early and late correlator gates is less than 1 chip.

Another tracking structure which became quite popular in the context of GNSS receivers is the High Resolution Correlator (HRC) [MB99]; where one extra pair of correlator gates (very early-very late) is used to form the discriminator. HRC is known in literature under various names (there might be small structural or implementation differences between these structures, but their discriminator output is basically the same, and they have the same performance): Double-Delta correlator, Pulse Aperture Correlator (PAC), Very Early-Very Late Correlator (VEVL), Strobe Correlator (SCORR), and Leika Multipath Mitigation correlator (LMM).

Narrow correlator and HRC correlator classes are heavily covered by patents, as it was shown previously in GREAT project reports.

1.2.1.2.2 Multipath mitigation for mass-market receivers

While coping well with noise and with BOC modulation in single path channels, the traditional correlators have only limited performance in multipath scenarios, and, especially, in short multipath cases. Therefore, many structures have been investigated in the literature in order to cope with multipath mitigation. In this section, we'll present the multipath mitigation techniques that have low complexity and/or reduced number of correlators, therefore being more suitable for mass-market receivers. In Section 3.2, we will also present the more advanced (and more complex) structures that can be suitable for professional receivers.

1.2.1.2.2.1 Parameter Estimation

The narrow correlator has already been shown in GREAT to approximate the one-dimensional Maximum Likelihood (ML) parameter estimation very closely. This approximation has been verified both theoretically by means of a stochastic gradient search and simulations of Multipath Error Envelopes (MEEs). If we look at Early-Minus-Late (EML) structures with a larger spacing, the results turned out to

be rather different from the ML results. However, ML parameter estimation allows determining a bias-free solution which provides results that are better than the NEML performance.

1.2.1.2.2.2 Multiple Gate Delays (MGD)

The Multiple Gate Delay (MGD) structures generalize the NEML and HRC algorithms to an arbitrary number of correlator pairs, with arbitrary spacings and arbitrary weighting coefficients. The arbitrary parameters are optimized according to MEEs [HLH+08]. As shown in [HLH+08], the optimized MGD structures do not have much better performance than HRC in multipaths, but their main advantage come from offering an un-patented solution to multipath delay tracking problem. It was also shown in [HLH+08] that the optimum parameters are typically dependent on the early-late spacings and on the type of non-linearity used in the non-coherent outputs (e.g., squared absolute values or absolute values). The optimum MGD structures have not been analyzed in the context of MBOC modulation so far.

1.2.1.2.2.3 Teager-Kaiser-based structures

The Teager-Kaiser-based estimators are based on the principle of extracting the signal energy corresponding to various channel paths via the non-linear Teager-Kaiser (TK) operator. The output $\Psi(x(n))$ of TK operator applied to a discrete signal $x(n)$ is given by [HLR03]

$$\Psi(x(n)) = x(n-1)x^*(n-1) - \frac{1}{2} \left(x(n-1)x^*(n) + x(n)x^*(n-2) \right) \quad (1-4)$$

The input of TK operator can be the correlation function. According to TK equation, 3 correlation values may be needed to compute TK (in-prompt, early and very early). The output of TK operator will signal the presence of a multipath component more clearly than looking directly at the correlation function [HLR03]. One-shot delay estimates based on TK for sine BOC(1,1) Galileo signals have been studied in [LLR06]. It was shown in there that the performance of TK is very promising in the context of Galileo signals. More recently, TK has been studied also in closed-loop configuration for sine BOC(1,1)-modulated signals, and its performance was one of the best among the considered algorithms [BHL+09]. One limitation of TK-based algorithms is the fact that they are quite sensitive to the filtering stages (i.e., when we do not have infinite bandwidth available). The impact of the bandwidth limitation on TK performance is however poorly documented in the literature.

1.2.1.2.2.4 A Posteriori Multipath Estimator (APME)

A simple structure to mitigate the multipaths has been proposed (and patented) by Septentrio, under the name of A Posteriori Multipath Estimator (APME) [SSN+03], [SLE01]. The idea is that, once we estimate the Line-Of-Sight (LOS) delay, we make a MultiPath (MP) correction which takes into account an average multipath behaviour via:

$$MP = -0.42 \left(1 - \frac{I_VE}{I_P(1 - \Delta_{EL})} \right) \quad (1-5)$$

Here, I_VE is the very early in-phase correlator, I_P is the in-prompt in-phase correlator, and Δ_{EL} is the early-late spacing. The APME coefficient of 0.42 has been derived from a multiple gate delay structure

with $M+N+1$ correlators, $\sum_{i=-M}^N \alpha_i \left(\frac{I_i}{I_P(1 - |i| \frac{\Delta_{EL}}{2})} \right)$, by choosing N , M and α_i values in such a way

to minimize the ranging error under various multipath profiles. The analysis is tedious and has been applied for GPS signals alone, but later the optimum parameters given in MP equation have been used in some Galileo applications as well. It is however still an open issue how well the APME fits the MBOC-modulated Galileo signals.

1.2.1.2.3 Open-loop versus close-loop architectures

The Complexity Reduced Multipath Mitigation (CRMM) proposed in GREAT has been investigated both with and without the loop filtering effects, i.e. we provided in GREAT an algorithm both open-loop as well as close-loop incorporating multipath mitigation. We compared the results to the tracking accuracy of the closed-loop NEML structure. The bandwidth of the loop filter enabled a further important degree of freedom to suppress the noise effects. The Mean Square Error (MSE) of the position estimation turned out

to be proportional to the loop bandwidth, which is why the incorporation of the loop filtering is crucial for the efficient and accurate parameter estimation using the CRMM methods.

1.2.1.3 Carrier tracking structures

By carrier tracking we understand the PLLs or carrier phase tracking and the Frequency Locked Loops (FLLs) or carrier frequency tracking.

Carrier phase tracking in most GNSS receivers is achieved with a Costas PLL loop. By driving the energy in quadrature phase to, zero the in-phase carrier is aligned with the incoming signal. The phase error between in-phase and the incoming carrier is given by the arctangent discriminator, $\arctan(Q/I)$. The punctual in-phase and quadrature phase measurements, I_p and Q_p , are often used because this is the code lag at which the CNR is maximum when the code is being accurately tracked. The carrier tracking loop therefore performs a form of null tracking such that Q_p is zero mean [BD97]. Traditional Costas loops work just fine for the normal CNR levels (e.g., outdoor) and for the signal dynamics within the tracking loop bandwidth. However, when a sudden acceleration occurs, the carrier tracking loop is most likely to lose lock if the resulting frequency error goes beyond the pull-in range. Furthermore, the nonlinearity of the carrier phase or frequency error discriminator, evaluated around the estimated frequency, also limits the region in which the carrier-tracking loop can operate.

Several architectures for **carrier phase tracking** exist [PDL08]:

- *Standard carrier tracking*, i.e., individual PLL tracking loop, based on Costas loop, for each satellite being tracked [PDL08]
- *Kalman filter-based carrier tracking (or joint code/carrier tracking)*, where the traditional discriminators and loop filters are replaced by a Kalman filter [PSI01b], [PDL08]. One Kalman filter is needed for each satellite being tracked. The benefit of the Kalman filter for error estimation is that it allows for weighting of the measurements (correlator outputs, in this case) based on their estimated accuracy. In this case, the weighting is based on the receiver's estimate of the carrier-to-noise density ratio. This is in contrast with traditional loop filters which assume all measurements (from the discriminators) contain an equal amount of information.
- *Vector-based approaches*, which use the navigation solution to drive the code and frequency Numerically Controlled Oscillators (NCOs) directly [PL06], [PDL08]; here the carrier phase tracking is not performed explicitly.
- *Ultra-tight receiver*: similar to the vector-based receiver except that it includes an Inertial Measurement Unit (IMU) to improve overall performance [GRE+05], [PDL08]

A comparison between the above 4 architectures in weak signal conditions and GPS C/A signal has been performed in [PDL08]; the conclusion was that the ultra-tight receiver has the best performance, followed by the Kalman estimator and by the standard carrier tracking receiver. The vector-based approaches gave (inexplicably) rather poor results. The sensitivity enhancement between the ultra-tight receiver and standard carrier tracking was about 7 dB, while the sensitivity improvement of the Kalman estimator over the standard receiver was about 5 dB.

With the exception of the standard carrier tracking, the other solutions are usually too complex for real-time applications, and seem not very suitable for mass-market applications.

In order to deal with BOC signal ambiguities, replacing \arctan with $\arctan2$ has been proposed, for example see [PIE02]. $\arctan2(Q_p/I_p)$ function gives the arc tangent of Q_p/I_p , taking into account which quadrant the point (Q_p, I_p) is in.

The **carrier frequency tracking**, typically done with a FLL is not so well studied in the literature in the context of GNSS receivers. Many times, it is assumed inherently to be incorporated in the PLL stage (i.e., no additional FLL [BAB+06]). Three FLL discriminator structures are proposed in [KH06]:

- *Cross-product discriminator*: $I_{n-1}Q_n - Q_{n-1}I_n$ (it works only for pilot channels or when successive bits have the same sign; it is near optimal at low Signal-to-Noise Ratio (SNR) and it has low computational burden)
- *Cross-sign(dot) discriminator*: $(I_{n-1}Q_n - Q_{n-1}I_n) \text{sign}(I_{n-1}I_n + Q_{n-1}Q_n)$: it is near optimal at high SNR and it has moderate computational burden; the data bits are not needed to be known (i.e., it is decision-directed).

- *Arctan2(cross,dot) discriminator*: $a \tan 2 \left(\frac{I_{n-1}I_n + Q_{n-1}Q_n}{I_{n-1}Q_n - Q_{n-1}I_n} \right)$: this is the optimum estimator, at both high and low SNR, but it has the highest complexity among the 3. It is also decision-directed.

Another unit to be optimized when dealing with carrier tracking loops which are individual for each satellite link is the loop filter. Basically, a carrier tracker consists of a discriminator, followed by a loop filter. The loop filter can be individual for PLL and PLL or joint for the two [KH06]. Loop filters (of first, second or third order) are presented in [KH06]. The first-order filters are sensitive to velocity stress, the second-order filters are sensitive to acceleration stress, and the third-order filter are sensitive to jerk stress.

Two innovative FLL-aided PLL loop filters have been proposed in [WAR98]: a second-order PLL filter with first-order FLL assist and a third-order PLL filter with second-order FLL assist. It was shown in there that a PLL-only mode is not recommended under high dynamic stress conditions, but rather a combination of FLL-only and FLL-aided PLL loops. The design of the loop filters for GNSS receivers has started to gain attention in recent literature [BSL09].

1.2.1.4 Different approaches for implementation of acquisition and tracking

In this section we give a short overview of balance between hardware software implementation in cost/flexibility point of view. Different approaches of implementing GPS receiver are illustrated in Figure 1-20. The same approaches can be extended to Galileo, and for the rest of the section we refer GNSS as combined GPS/Galileo.

In the rigid approach (right hand side) all functionality of the GNSS receiver is implemented in dedicated hardware, this approach might appear low unit price if high volumes are produced, but the design cannot be changed or upgraded anymore. Thus, this approach is feasible when technologies used have reached maturity and all desired algorithms have been implemented (i.e., there are no more research around advanced algorithms).

In next approach hardware produces GNSS measurements, i.e. pseudo ranges, and the navigation load is moved to host processor. This approach has a bit more flexibility, and some advanced features can be upgraded to design, e.g., aiding information for navigation software coming from Wireless Local Area Network (WLAN) or mobile network. But the correlator engine is fixed and advanced tracking algorithms cannot be updated.

Next step moves the control over baseband to software; here correlators are implemented as “dummy”, reconfigurable engine, which can be altered at some level (e.g., predefined alternatives of spacing of correlators, fixed upper limit on number of correlators). But the feedback part can be altered freely, e.g. weighting factors for MGD algorithms.

The most flexible approach implements everything after ADC as software, here algorithms are upgradeable but the reported [SJK+08] requirements for host processor are too high when aiming to mass market, mobile, platforms.

In GRAMMAR, the used solution (TUTGNSS) is following the approach of accelerated SW GNSS, where all decisions (loop feedback, loop filtering, etc.) are made by software, since this approach gives the highest degree of flexibility (for advanced algorithms) with host processor requirements still achievable to targeted market segment.

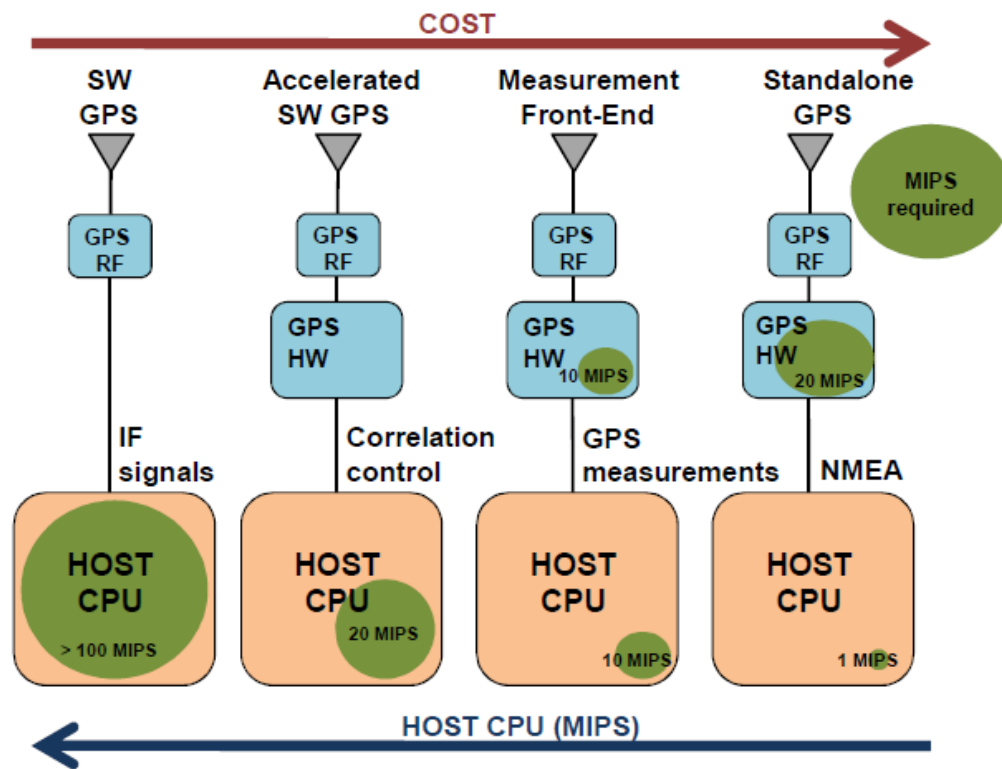

Figure 1-20: Different receiver approaches. Source: [SJK+08]

1.2.2 Interference mitigation

While extended results concerning multipath effect on modernized GPS and Galileo signals are available in literature, the potential impacts of interference signals on GPS L1C and Galileo E1 OS signals is a topic not deeply investigated, yet. There are two aspects to be considered when dealing with narrowband and wideband interference in GNSS:

- First, we need to find out how much the interference affects the receiver performance, when no additional processing is done. The interference-related performance curves are rather scarce in the current literature. One example is based on a new family of curves, called Interference Error Envelope (IEE), has been recently introduced and already presented in [MSM08] as a valuable tool for assessing the interference on receiver performance considering different GNSS signals in different operative conditions. Another possibility is to use the Spectral Separation Coefficients (SSCs) [BET99], [LLR06] as measures for wideband interference levels or the Interference-to-Signal Ratio.
- Secondly, if the performance deterioration is significant, we need to derive low-cost methods to cancel or diminish the interference.

In the next two sub-sections we review the low-cost solutions proposed in the literature so far in order to deal with various types of interference.

1.2.2.1 Narrowband interference

The received GNSS signals are very weak, usually in the order of -130dBm. The GNSS receivers therefore have to be very sensitive in order to be able to process these signals, which indirectly make them very sensitive to the potential narrowband interferers present in their environment [CCW+06].

MBOC is typically credited to be less susceptible to narrowband interference than BPSK and sine BOC(1,1) modulations [HAW06]. However, it was shown in [MPL08] that if the narrowband interference is centred at 6 MHz from the IF, when the power of the interference increases, the performance of the CBOC become worse than for the sine BOC(1,1) (the advantage of CBOC over sine BOC(1,1) in terms of narrowband interference remains only if the narrow band interference is centred at 1 MHz from the IF. An important category of narrowband interferers is the pulsed interference in the E5 band from Distance

Measurement Equipments (DME) and Tactical Air Navigation (TACAN). TACAN-DME navigation equipments operate in the UHF spectrum between 962 and 1213 MHz, thus interfering with E5a and E5b inside 1164-1213 MHz bandwidth. Typical interference mitigation of TACAN-DME pulses is achieved via pulse blanking techniques [ABC+08], [Gao07].

Narrowband interference rejection can be done either in the RF front-end part [CCW+06], or in baseband. However, the main solutions found in the literature for narrowband interference rejection in baseband seem rather complex for mass-market applications. We will give an overview of the on baseband solutions for narrowband interference rejection in Section 3.10.

The only promising approach in the context of mass-market receiver (based on our literature research) seems to be the use of the *differential correlation* methods [SHA07], [SHA06]. Differential correlation methods have been widely studied in the context of CDMA acquisition, and have recently gained some interest also for GNSS applications [SN04], [HAI+05], [SHA07], [SHA06]. The differential correlation algorithm applied for narrowband interference mitigation in [SHA07], [SHA06] was named via Multi-Correlation Differential Detection (MCDD). MCDD was shown to offer about 2-3 dB better performance than the non-coherent acquisition methods in the presence of narrowband interferers on GPS C/A signal [SHA07].

Dual-frequency receiver architecture can be beneficial when dealing with narrowband interference, since it is unlikely to have both frequencies affected by a narrowband interferer at the same time. Deriving good estimators of the level of narrowband interference is an issue not much addressed in the GNSS literature.

1.2.2.2 Wideband interference

Wideband interference typically refers to the interference coming from other wideband systems sharing the same frequency bands with Galileo. Of course, the additive background noises (e.g., modelled via Additive White Gaussian Noise (AWGN)) are also a form of wideband interference, but this section is mainly focusing on the interference coming from other wideband signals. Such wideband interference can be classified into inter-system interference (e.g., between GPS and Galileo signals sharing the same frequency bands) and intra-system interference (between Galileo signals on the same frequency band; e.g., between data and pilot channels on E1 band).

1.2.2.2.1 Inter-system interference

Some of the existing wideband systems that are likely to interfere with Galileo frequencies are:

- GPS L1 (interfering with Galileo E1)
- GPS L5 (interfering with Galileo E5a)
- Some satellite communication systems such as Eumetsat use a carrier at 1544.5 MHz (partially overlapping E1 band)
- Digital Audio Broadcasting (DAB) transmits in the 1452-1492 MHz band (close to E1 band); when Ultra-Wide Band (UWB) technology is used for DAB, interference with Galileo can be significant

Moreover, inter-modulation products due to various non-linearities of systems with more distant carrier frequency can also fall within the Galileo bands. The inter-modulation effects are typically addressed at RF front-end stage, and therefore they will not be considered here.

The inter-system interference is inherently reduced when using different modulation types (e.g., BPSK in GPS C/A code and CBOC in Galileo E1). From the point of view of a mass-market receiver, the benefits of an additional wideband interference cancellation unit (besides a good design of the signal modulation types) are questionable, especially when most of the wideband interference cancellation methods are based on multi-antenna arrays [LFW06].

1.2.2.2.2 Intra-system interference

By intra-system interference we refer here to the interference caused by different signals of Galileo, sharing the same band.

We remark that the term of ‘intra-system interference’ is sometimes used with a different meaning, that is, it may refer to the interference between transmitter and receiver in full duplex transmissions, or between the interference caused by the re-use of various receiver blocks in a multi-system approach (e.g., Universal Mobile Telecommunications System (UMTS)-GPS receiver).

Both intra- and inter-system wideband interferences can be generally lumped into the additive background interference and treated as a usual additive white noise source.

More about interference cancellation methods will be discussed in Section 3.10.

1.2.3 Receiver adaptation to signal conditions

In order to increase the overall receiver performance, the acquisition and tracking algorithms could be configured differently in different signal conditions. Typically, this adaptation needs two steps: in the first step, the channel conditions are estimated (e.g., low versus high CNR, single versus multi-path, level of interference, etc), while in the second step a suitable acquisition and tracking algorithm is chosen according to the channel conditions. Alternatively, implicit channel conditions estimation might be employed. The area of adaptive GNSS receivers is rather poorly covered in the current literature.

Often the adaptation to channel conditions is encountered in the formation of a threshold. For example, an SNR-adaptive acquisition algorithm for GPS signals is presented in [CF+06] where an SNR-dependent Peak Detection Threshold (PDT(SNR)) is employed. More precisely, the SNR detection is done by comparing the standard deviation of the received signal with surrounding noises. The target is to increase the probability of successful rate by adjusting the threshold according to the SNR conditions (i.e., poor or strong). Another adaptive threshold is computed in [VSA+04], where the authors present a CNR-adaptive acquisition scheme of Gold sequences (i.e., used in GPS) which is based on their partial correlation characteristics. More precisely, the system estimates the Carrier-to-Noise-Ratio in the following way: first, it computes the percentage of incorrect cells (phases) passed through the first dwell, then this percentage is multiplied with a scaling factor which is finally used as a new threshold to keep the percentage of cells passing through the first dwell in a desired constant range.

A Peak Tracking (PT) method with adaptive threshold has been introduced in [BLR07]. The PT method utilizes the adaptive threshold computed from the estimated noise variance of the channel in order to decide on the correct code delay [BLR08]. Therefore, the algorithm adapts to the signal condition by measuring the noise variance of the out-of-peak values (i.e. the out-of-peak values are those peaks which are, for example, ± 1 chip away from the maximum peak) while computing the adaptive threshold. The Peak Tracking method first generates a set of competitive peaks which are above the computed adaptive threshold. The competitive peaks are then multiplied by some optimized weighting factors, which are assigned based on the peak power, the peak position and the delay difference of the peak from the previous delay estimate. Finally, PT selects the peak which has the maximum weight as being the best LOS candidate [BLR08]. PT requires a huge number of correlators (for example, 81 correlators with 0.05 chips correlator spacing in order to cover the code-delay range of ± 2 chips for noise computation), which eventually increases the complexity of the algorithm.

A Carrier-to-Noise Ratio (CNR) identifier for separating the indoor and outdoor regions in satellite-based navigation applications has been presented in [SL+07]. This CNR identifier is based on the Level Crossing Rate (LCR) of the non-coherently averaged correlation function between the incoming signal and the reference code; the results showed that by using the proposed identifier, it is possible to distinguish the indoor from outdoor scenarios up to 80% to 95% of the cases. In general, the LCR information can be used for distinguishing between poor and good CNR conditions. This is done in [SL+08] where a discontinuity-based code delay estimator for GNSS signals is presented. More precisely, the tracker incorporates the LCR information in order to compute a threshold which filters out part of the noise of the non-coherently averaged correlation function. An LCR-based threshold is also used in [SSL+09] where an iterative deconvolution method for estimating jointly the Line-Of-Sight code delay and carrier phase of GNSS signals is proposed. In particular, this threshold is used in the update rule of the algorithm with the aim of reducing the noise, present at the solution formation of each iteration step. In [CA+98], an adaptive SNR-based carrier phase multipath mitigation technique for GPS differential measurements is introduced. Particularly, it adaptively estimates the spectral parameters (frequency, amplitude, phase offset) of multipath in the associated signal-to-noise ratio (SNR), and then constructs a profile of the multipath error in the carrier phase. Then, a multipath correction is made by subtracting the profile from the actual phase measurement data.

1.3 Hybrid data fusion

1.3.1 Positioning with WLAN

Although not designed for positioning purposes, wireless communication systems provide appealing signals of opportunity for position estimation, as their signal characteristics depend on location. WLAN (also known as Wi-Fi) is nowadays commonly available in public and office buildings, which makes it one of the most promising indoor positioning methods in the near future, at least for inexpensive consumer products.

WLAN positioning methods based on either Received Signal Strengths (RSS) or Time of Arrival (TOA) measurements are reported in the literature. Examples of RSS based WLAN positioning can be found in e.g. [BPR00], [BNV02], [PKC02], and [RMT02], [SK02], [WW04], and TOA based WLAN positioning in [CCB07], [GB07], [ICB+06].

In applications targeted for mass market products, the availability of RSS measurements is more probable, as the mobile terminal can obtain them by passive scanning of WLAN beacon frames, which WLAN Access Points (AP) emit periodically. In addition, in many mobile devices, such as mobile phones, Personal Digital Assistants (PDAs) and laptop computers, RSS measurements are easily available through Application Programming Interfaces (APIs) of their standard WLAN services.

The algorithms used in WLAN RSS based positioning can be divided into three main categories: cell identifier based methods, trilateration, and fingerprinting.

Cell identifier method

In cell identifier method, the Mobile Terminal (MT) scans the available WLAN channels. As its position estimate it reports the position of the AP from which it received the strongest signal. In cell identifier method, a MT needs prior information about the locations of APs and their unique Media Access Control (MAC) addresses. The method is applicable in scenarios where high accuracy is not required or where position technology is not the main focus. The obtainable accuracy is dominated by two factors: the distances between APs in the WLAN network, generally introducing considerable granularity of the positioning, and noise in RSS measurements caused by environment. Nowadays, when most WLAN base stations offer more than one channels to be detected on WLAN scans, the effect of measurement noise can be decreased using RSS based weighting and counting to increase the reliability of the positioning results by cell identifier method [FH08], [Her06].

Trilateration

In trilateration systems, path loss models of radio signals are used to translate RSS measurements to distances between the receiver and APs [SK02], [WW04]. As in cell identifier based positioning methods, the MT needs prior information about the MAC addresses and locations of APs. In indoor environments, multipath and attenuation caused by walls, other structures, and even people complicate the modelling of signal propagation. This makes the simple path loss models too inaccurate in many real life situations. To overcome this problem, the performance of triangulation can be enhanced using other models, such as pattern matching [SK02] and probabilistic filtering approach [WW04].

Fingerprinting

Fingerprinting approaches are based on experimental models that relate the measured RSS values to the measurement position. These experimental models, also called radio maps, are based on off-line collected data from several locations that sufficiently cover the area of the radio map. Fingerprinting algorithms are considered to be more robust against signal propagation errors as they actually make use of location dependent error characteristics of radio signals. The procedure for radio map creation is often called calibration or training, referring to calibration or training of the experimental model and the required data is called calibration or training data. The locations where the calibration data is collected are called Calibration Points (CPs). In estimation phase, new measurement vectors are related with the information stored in radio map. A known disadvantage in fingerprinting approaches is the fact that the collection of calibration data is laborious and time consuming. The two phases of fingerprinting based position estimation are shown in Figure 1-21.

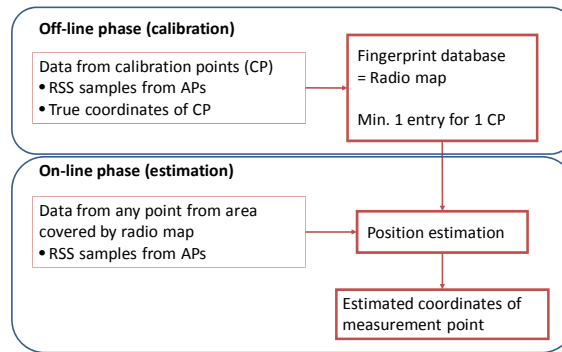

Figure 1-21: Two processing phases of fingerprinting based positioning

1.3.2 Positioning with cellular communications systems

Investigating state-of-the-art and already standardized systems (e.g., Global System for Mobile communications (GSM), UMTS) it became obvious that the position information was not apriori part of the system but was seen more as an “add-on” to these communications systems. Hence, these systems have been designed for communications purposes only. However, encouraged by the Federal Communications Commission (FCC) requirements and the demand on “GPS-free” location information in Mobile Stations (MSs) the systems were extended to allow also stand-alone positioning.

In the following, we describe the standardized technologies in Second-Generation (2G) and Third-Generation (3G) systems. Main parts of the following contribution are taken from [Zha00] and [Zha02] which are good overview papers about the relevant procedures, and the relevant standard documents.

1.3.2.1 Positioning in 2G systems

For 2G GSM systems mainly three approaches have been standardized [ETS00] and will be described in the following sections.

Enhanced Observed Time Difference

For GSM, the main stand-alone location technology is based on Time Difference Of Arrival (TDOA) and called Enhanced Observed Time Difference (E-OTD). E-OTD has been finalized by the GSM standard committees in LCS Release 98 and Release 99. E-OTD is a TDOA positioning method based on the Observed Time Difference (OTD) feature that a part of GSM for communications purposes. There, the MS measures the relative time of arrival of the signal bursts from several Base Stations (BSs). The position of the MS is then determined by hyperbolic positioning techniques. Generally, there are three timing quantities involved in this method:

- OTD is the time interval observed by an MS between the receptions of signal bursts from two different BSs.
- As Real Time Difference (RTD) the relative synchronization in the network between two related BSs is given.
- The Geometric Time Difference (GTD) is the time interval measured at the MS between bursts from two BSs due to the overall geometry.

Hence, we have the relation between the involved time differences given as

$$\text{GTD} = \text{OTD} - \text{RTD}. \quad (1.6)$$

The OTD can be measured at the MS by detecting the arrival time of bursts transmitted from several BSs. For synchronized networks the RTD is equal to zero, and hence the GTD equals OTD. For non-synchronized networks the RTD could be measured by so-called Location Measurement Units (LMUs) which are part of the infrastructure. The LMUs thus can determine the asynchronism of the network and provide it to the MS (see below).

Another method in the framework of E-OTD measures the time of arrival of the signals from a BS to the MS and to the network node LMU. The following quantities are used:

- Observed time from a BS to the MS (MOT) as time measured against the internal clock of the MS.
- Observed time from a BS to the LMU (LOT) as time measured against the internal clock of the LMU.
- Time offset ε as bias between the two internal clocks of the MS and LMU.
- Distance from MS to BS (DMB).
- Distance from LMU to BS (DLB).

Hence, we have the relation between the involved measurements given as

$$\text{DMB} - \text{DLB} = c(\text{MOT} - \text{LOT} + \varepsilon). \quad (1.7)$$

For each BS one of these relations can be found. Since there are three unknowns included (two-dimensional MS position and clock offset ε), at least three BSs are required to find a unique solution.

E-OTD in general requires a minimum of three different BSs where all of these BSs. More than three measurements generally produce better location accuracies. An implementation of the E-OTD method requires an LMU to BS ratio between 1:3 and 1:5.

Uplink Time of Arrival

Also a TOA procedure has been specified and standardized for GSM. It is the so-called network based Uplink TOA (U-TOA) method.

This method is based on measuring the TOA of a known signal burst from the MS at three or more LMUs in the infrastructure. The known signal is the access burst generated by the MS to perform an asynchronous handover.

After the signal measurements at the network nodes, the TDOA approach is used to determine the position of the MS. Hence, it calculates the time difference of at least two pairs of TOA signals and derives the MS position by hyperbolic techniques according to TDOA. Therefore, U-TOA it is a hybrid method combining TOA and TDOA. The position calculation or solution of the navigation equation can be done in the same way as shown for E-OTD. The only difference is that in network based U-TOA the computation is performed in the infrastructure, whereas the in E-OTD it is done in the MS.

It was shown that U-TOA is more effective at reducing noise and interference through correlation and burst averaging than E-OTD. On the other hand, a higher deployment density was expected of the E-OTD LMU due to the impact of RTD error on the MS location accuracy.

Assisted GPS

Assisted GPS (A-GPS) approaches were specified to improve the performance of GPS:

- Improve the time to first fix.
- Better reception of weak signals in urban canyons or indoor especially for cellular-sized antennas.
- Reduce power consumption by reducing signal acquisition time.

The main idea of A-GPS is to set-up a GPS reference network (or equivalently a wide-area Differential GPS (DGPS) network) where the receivers have clear sky-views. This reference network is additionally connected with the cellular infrastructure, continuously monitors the real-time constellation status, and provides data such as approximate MS position (or BS location), satellite visibility, ephemeris and clock correction, Doppler, and the code phases for each satellite. On demand the assistance data is then transmitted to the MS or network nodes for fast start-up and increases sensitivity. When the available satellite signals are detected, the pseudo-range measurements can be delivered to the network for position calculation or used internally in the MS to compute its position. Additional assisted data, such as real-time integrity, DGPS corrections, satellite almanac, ionospheric delay, and Coordinated Universal Time (UTC) offset can be transmitted.

There are two fundamental modes that are supported:

The MS-assisted solution shifts the majority of the GPS receiver functions to the network processor. This method requires at least an antenna, RF section, and base-band processor in the MS for making measurements by generating replica codes and correlating them with the received GPS signals. By A-GPS

an assistance message is sent to the MS, consisting of time, visible satellite list, satellite signal Doppler and code phase, as well as their search windows or, alternatively, approximate handset position and ephemeris. The assistance data of Doppler and code phase is usually valid for a few minutes, while ephemeris data for around two to four hours. From the MS the pseudo-range data is returned to the network. Then, the location server estimates the position of the MS. Additionally, differential correction in terms of DGPS can be applied to the pseudo-range data or final result at the network side to improve the position accuracy.

For MS-based solutions a complete GPS receiver is integrated in the handset. In the start-up phase, satellite orbital elements (ephemeris) must be provided to the MS. This data is valid for two to four hours and can be extended to cover the entire visible period of the GPS satellite (i.e., up to 12 hours). For better positional accuracy or longer ephemeris life, differential correction (DGPS) data could be transmitted to the MS. The final position of the MS is generated at the MS. Then, the estimated MS position can be sent to the network if required.

Comparing GSM and UMTS, similar features are included in 3GPP/3GPP2 as in the 2G standards. To reduce infrastructure investment, a shared location server could be implemented to support MSs operating in both 2G and 3G networks.

However, the cellular time base is in general different for GSM and UMTS. In GSM, cellular network time can be expressed in terms of BCCH carrier, BSIC, frame number, time slot number, and bit number. For UMTS, it can be expressed in terms of UTRAN-GPS timing of cell frames, primary CPICH info, and SFN. The uncertainty between cellular and GPS time is included in the GSM field "GPS Reference Time Uncertainty" and in the UMTS field "SFN-TOW Uncertainty".

Since GSM and UMTS MSs do not have precise time information available internally, methods are included in the standards protocol to deliver precise time to the GSM/UMTS handset [3GPP25305]. To accomplish precise time transfer in asynchronous GSM/UMTS networks, LMUs can be used. For A-GPS, the LMU measures the relation between cellular frames from the serving BS with respect to GPS time and send this information periodically to the network. The network collects the time stamp information, and maintains a data base of the relationship between cell timing and GPS time for every BS. This information is then sent to the MS. Nevertheless, installing LMUs in the network is rather expensive for a network operator. Therefore, the GSM/UMTS standard also allows the MS to perform the LMU function [3GPP25305]. In that sense, after a position request the MS reports the difference between cellular time and GPS time to the network. The network then can use this information for assistance of other MSs. Hence, also in GSM/UMTS it is possible to substantially reduce the contribution of time error.

1.3.2.2 Positioning in 3G systems

Three location techniques have been specified for UMTS Terrestrial Radio Access Network (UTRAN) [3GPP25123] [3GPP25133] [3GPP25215] [3GPP25225] [3GPP25305] [3GPP25331]: cell-ID based, Observed TDOA (OTDOA), and A-GPS methods. Note that except for the MS-assisted OTDOA method, the rest of the methods are optional in the MS.

Cell ID Based

Using the cell ID approach the MS position can be roughly determined in the network as specified for 3rd Generation Partnership Project (3GPP). There, the MS position is estimated based on the coverage information of the serving BSs. This knowledge could be obtained e.g., by paging, locating area update, cell update, UTRAN registration area update, or routing area update. Even though this method is optional for the network, this approach should be implemented as the default location method. It is the fall-back solution if OTDOA or A-GPS fail.

However, this method provides a position error as large as the cell area if no additional measurements are used. For instance, a small pico-cell could be 150 m in radius, while a large cell could be more than 30 km in radius.

Observed Time Difference of Arrival

Also for 3G systems a TDOA positioning method is specified for 3GPP. In OTDOA the position of the MS is determined by hyperbolic positioning. Two methods are specified for OTDOA: MS-assisted OTDOA and MS-based OTDOA.

Since the measurements are based on the signals from BSs, the locations of these BSs are necessary for the network or MS to calculate the MS positions. If the transmitters in UTRAN are non-synchronized, the RTD must be provided (similar as for 2G systems) by so-called System Frame Numbers (SFNs). It is named SFN-SFN OTD. One way to obtain these measurements is again to deploy LMUs, which perform timing measurements of all the local transmitters in fixed locations of the network. These measurements can then be converted to RTDs and transmitted to the MS or network for position estimation. In addition, the MS measures the SFN-SFN OTD, which identifies the time difference between two cells as TDOA. Two types are defined. Type 1 is used for soft handover and type 2 is used for positioning. The main difference of these two types is that type 2 is applicable for both idle and connected modes, while type 1 supports intra-frequency measurements and cannot do inter-frequency measurements for the connected mode. Since BSs in Time-Division Duplex (TDD) mode are generally synchronized, the RTDs should typically be constant. Similarly, in Frequency-Division Duplex (FDD) if the relevant cells are synchronized, measurements of RTDs would not be necessary. For FDD mode, Round-Trip Time (RTT) and receiver-transmitter time difference can be obtained to improve the performance of the OTDOA measurements. For TDD mode, receiver timing deviation can be obtained to improve the performance.

Main limiting factors of OTDOA location are hearability and non-synchronized BSs for FDD. Hearability problems occur when the MS is close to its serving BS, which could block the reception of other signals from other BSs in the same frequency. This can be a fundamental problem since the MS must be able to hear at least three BSs for positioning. In order to improve the hearability of neighbouring BSs, one specified option is the Idle Period DownLink (IPDL). There, each BS interrupts its transmission for short periods of time (so-called idle periods). During these idle periods, the MSs within the cell can measure signals from other BSs. Since the IPDL method is based on downlink transmission, the location service can be provided easily to a large number of MSs at the same time.

For MS-assisted OTDOA, essential information elements or assistance data from UTRAN to MS are reference and neighbour cell information. For MS-based OTDOA, they are reference and neighbour cell information as well as BS positions of these cells. MS-assisted OTDOA is mandatory for the MS and optional for the UTRAN. The MS-based OTDOA is optional for both the MS and UTRAN.

Advanced Forward Link Trilateration

Advanced Forward Link Trilateration (A-FLT) is standardized by 3rd Generation Partnership Project 2 (3GPP2). Contrary to GSM or UMTS, CDMA (Interim Standard 95 (IS-95)) is a dedicated time-synchronized system. Therefore, time-difference measurements are much easier. The basic idea of the A-FLT method is to measure the time difference (phase delay) between CDMA pilot signal pairs. Each pair consists of the serving cell pilot and a neighbouring pilot. The time difference is then converted to the range information. Then triangulation techniques can be applied for position estimation.

Although the name of this method implies that A-FLT is a MS-based solution, the location can be determined either at the MS or at the network. For an MS-based solution, the MS must determine the time difference of arrival among multiple pilot signals through its searcher. For an MS-assisted solution, the pilot signal measurement message along with the round-trip delay can be used to determine the time differences. Since the basic principle of this method is TDOA, the navigation equation can be solved as shown for E-OTD or OTDOA.

1.3.2.3 Positioning in beyond 3G systems

The standardization process for beyond 3G systems is still on-going. However, positioning support has attracted attention and will be an integral part of such systems. For instance, in 3GPP-LTE it was set-up a working item for further considerations [LTE-080995]. The resulting multi-link synchronization problem is currently under investigation for positioning with 3GPP-LTE macro BSs. Just recently, different positioning approaches and their performance assessment are discussed in the 3GPP-LTE community [LTE-090353][LTE-090765][LTE-090918]. In these approaches the hearability of neighbouring BSs due to interference was identified as limiting factor for positioning applications for the targeted system frequency re-use of one. Different approaches were proposed to overcome this limitation (e.g., idle-periods of the base stations, more pilot symbols, higher frequency re-use factor).

Also in system proposals that are still in the research phase, like the 4G proposal by WINNER [WIN09], positioning support is under investigations. For instance, in [WIN481][WIN482] TDOA was proposed as main method for obtaining position information.

1.3.2.4 Implementation status and integration with GNSS

Although several methods and approaches are included in the standards for 3GPP and 3GPP2, currently not all of them have been implemented and deployed. Clearly, there are a lot of differences with respect to different regions. For instance, in the United States a main driver for positioning support were the requirements defined by the Federal Communications Commission (FCC) stating that emergency callers have to be located with specified accuracy. The requirements are expressed in circular error probability (CEP). For network-based positioning solutions, a position accuracy of at least 100m should be achieved in 67% of the emergency calls and of at least 300m in 95% of the emergency calls. In case of handset based positioning solutions, on which the current report focuses, the accuracies should increase to 50m for 67% of the calls and 150m to 95% of the calls. So for meeting these E-911 requirements the providers have deployed different approaches. According to [WMY08], T-Mobile and AT&T have implemented E-OTD for their GSM networks. Sprint-Nextel, Verizon, QWEST, and Alltel use A-GPS and A-FLT for their CDMA networks. The achievable accuracy is within 50m-200m for E-OTD/A-FLT and 5m-30m for A-GPS strongly depending on the scenario. If these methods fail, the Cell ID can still be used as fallback solution providing accuracies between 100m and 30km depending on the cell sizes [WMY08]. Nevertheless, in 2007 the FCC fined Sprint-Nextel, Alltel, and US Cellular for failing to meet E-911 requirements in 2005. They were not able to meet the 95% coverage requirement for E911 in 2005.

Common European agreements about accuracy requirements for location determination of emergency calls are not yet well defined. Nevertheless, the Coordination Group on Access to Location Information for Emergency Services (CGALIES) has developed a "Report on Implementation Issues Related to Access to Location Information by Emergency Services (E-112) in the European Union" [CGA02]. But currently there is no common agreement about these requirements. Another problem for deployment in Europe is the non-synchronized GSM/UMTS network (compared to the GPS-synchronized CDMA2000 networks in the United States). It makes the implementation of methods like E-OTD/OTDOA difficult since expensive LMU equipment is needed. However, for OTDOA it was shown in 3GPP that a positioning accuracy of 50m-150m can be achieved [3GPP020372]. With advanced methods like IPDL-OTDOA or software blanking OTDOA this can be improved to 30m-60m and 15m-30m in principle.

Concerning A-GPS solutions, as it was pointed out before, several approaches are standardized. Nevertheless, there exist also other non-system-internal solutions to provide the MS side-information for fast GPS access. For instance, the satellite almanac can be provided via a standard data-link or can be downloaded in advance. It then is valid only for a certain time (e.g., a couple of days). However, precise code phase search information or coarse position estimates by reference BSs as it can be provided by standardized solutions cannot be used here.

One research topic of GRAMMAR in this context is the tight hybrid data fusion of GNSS with measurements from a cellular network (with focus on 3GPP-LTE TDOA measurements). Although the tight hybrid data fusion of GNSS and measurements from a cellular network has been widely studied (cf. the extensive investigation within the GREAT project), the main implemented and commercial available solutions rely on a loose hybrid data fusion. In that manner, the supported positioning systems (e.g., GNSS, cellular, Wi-Fi) provide independent location estimates depending on availability which are then fused in a second step. Hence, fusion on the pseudo-range or TDOA level is usually not performed. For instance, Skyhook Wireless [SKY09] provides its XPS solution combining the location sources Wi-Fi, GPS, and cellular radio (GSM/CDMA) to determine the MS position with an accuracy of 10 to 20 meters. For Wi-Fi, a database with available access points is used to determine the position. In the same sense, for the cellular approach a database of the BSs is used. XPS then provides the overall best solution promising an availability of 99.8% at an accuracy of 10m [SKY09]. Whereas Skyhook Wireless proposes a more "software-driven" approach using standard features for WIFI and cellular (like Cell IDs), complete integrations of different approaches are available as well. For instance, Qualcomm merchandizes its gpson solution [QUA09]. According to the specifications, it is compatible with Qualcomm's QPoint Location Based Server as well as 3GPP and GERAN compliant location servers supporting UMTS control plane and GSM control plane and OMA SUPL 1.0. Nevertheless, an explicit tight fusion of GNSS and other sensors is not mentioned there.

1.3.3 Positioning with other sensors

Self-contained sensors such as gyroscopes and magnetometers can be directly applied to improve the heading estimate of GNSS receivers. Especially at low speeds the velocity-based heading is often too inaccurate for orienting the map on a display, for example. Barometric altimeters can be used to increase resolution of the GNSS receiver vertical channel, and even to remove one unknown from the positioning equation. One-antenna GNSS receiver cannot solve its orientation, sensors (Three-Dimensional (3D)

magnetometer - 3D accelerometer combination, for example) can be used to bring this information to the positioning application.

Often in indoor environment or when approaching a building from outdoors the GNSS signals are not available at all. In these situations position estimation must be based completely on sensor information. Well-known application of using sensors in navigation is Inertial Navigation System (INS), where data from three accelerometers and three gyroscopes are used to compute changes in position. INS mechanization involves double-integration of acceleration measurements, and thus even a small bias in acceleration yields a large position error drift in the output. In addition, the accelerations need to be transformed to a locally level frame using gyroscope data. Any bias in gyroscope output causes a position error which increases with time cubed, as there is additional integration process in this transformation. As the requirements for sensor accuracies are very strict, it is very unlikely that INS mechanisation would be applied in mass-market GNSS receivers in the near future. Pedestrian Dead Reckoning (PDR) is one way to reduce the effects of sensor biases that are problematic in the INS mechanization. In PDR, instead of double-integrating the accelerations, steps are detected from the acceleration waveform. This information, along with estimated step-length and heading is used to propagate user position. It can be shown that PDR mechanization is superior to INS for a person on foot [MCG05]. The main drawback of PDR is the limitation to one motion mode; the mechanization works only when walking. INS works without any assumptions about the user motion. Commercial PDR units are available [Hon].

In addition to providing direct navigational information, there are other ways to use sensor information to aid GNSS receiver. For example, accelerometers can be used to detect stationary receiver. This information can be used in the receiver positioning filter to improve accuracy, or the receiver can be shut-down to save power (see e.g. [SK08]). Doppler positioning is also possible, whenever it is known that the receiver is stationary [Leh02].

As Micro-Electro-Mechanical System (MEMS) and other miniature sensor technologies evolve continuously, size, cost and power consumption of the sensors are decreasing rapidly. For example, 3-axis accelerometers with 10 μ A current consumption and 2x2x1 mm³ package size are already available [VTI09]. Table 1.3 lists sensor types that could possibly be included in mass-market GNSS receiver.

Table 1.3: Sensor types suitable for mass-market GNSS receiver.

| Sensor type | Measurement; navigational signal | Manufacturers (not exhaustive list) |
|----------------------|--|---|
| <i>Accelerometer</i> | Specific force; roll, pitch, acceleration | Analog Devices, ST Microelectronics, VTI Technologies |
| <i>Barometer</i> | Atmospheric pressure; altitude | Freescale Semiconductor, VTI Technologies |
| <i>Gyroscope</i> | Angular rate; heading, attitude | Murata, Analog Devices |
| <i>Magnetometer</i> | Magnetic field; heading | Honeywell |

1.3.4 Indoor map-matching

Map-matching is a well-known method for improving positioning accuracy in vehicular navigation. The digital road network map is an important component of a modern navigation system. A map database is a source of valuable information that can be used to improve the accuracy of the position given by the GPS/Dead Reckoning (DR) navigation system and calibrate the DR sensors. This process of position update and verification using maps is called map-matching. In most vehicular applications, map-matching is implemented by adding constraints to position solution, which commonly is obtained using Extended Kalman Filter (EKF).

Map-matching algorithms usually consist of two steps: identification of the road link where vehicle is most likely travelling and estimation of vehicle position on the selected road link. Three groups of map-matching algorithms can be found in the literature: Semi-deterministic algorithms, Probabilistic algorithms, and Fuzzy logic based map-matching. One of the important tasks of map matching algorithms

is to select the correct link among the candidate links since an incorrect selection can lead to a sequence of wrong selections. Accurate link identification is critical especially in dense urban areas where the average distance between roads is very small. Consequently, the possibility of error must be reduced by taking into account all available data from the navigation sensors and the digital map. The heading and speed of the receiver can play a vital role in selecting the correct link, especially at junctions where the speed is comparatively low. It should be noted that heading measurements from GPS tend to be unstable at low speed. However, this can be improved when heading is measured with DR gyro sensor.

In indoor environment, the constraints set by wall affect differently. Instead of constraining the user location to some defined pathways, the walls only prevent the movement to some directions, while doors and open space allow movement. When compared to car movement on the road network, the mobile users walking in indoor environment appear to be less predictable.

Research on mobile robot navigation has produced two major paradigms for mapping indoor environments: grid based and topological [KH06b]. Topological maps for indoor environment are quite similar to the representation used for road networks. These maps consist of nodes, which are connected by links. The nodes are used to represent rooms, intersections between hallways, and other important points of interest. Each link is composed by a starting node and an ending node. In the physical world, a link represents features of the environment that allow movement, such as corridors, doors, stairs and elevators. Attributes associated to nodes are for example type of node (e.g. crossing, connector) and fixed coordinates of the node. Link attributes include the type of link (e.g. horizontal, vertical), link length and direction. A grid map divides the environment in cells, typically equal-sized and square-shaped. For each cell a number is associated that reflects the probability of the cell being occupied by an object, which may be, e.g., a wall, an obstacle, or a person.

1.3.5 Fingerprinting

There are several signals that represent location dependent characteristics, typically error characteristics such as distortions introduced by the environment of the observer. Such signals include radio signals, e.g. WLAN, Bluetooth, GSM, and UMTS signals; also the Earth magnetic field shows location dependent behaviour, and especially indoors there local distortions caused by manmade structures can be observed and used to aid positioning [SR09].

Location fingerprinting methods can be categorized in pattern recognition and probabilistic algorithms. Usually a pattern vector contains information of the RSS values of all the channels of the APs in the area, i.e., there is at least one element for each AP in the pattern vector. In the radio map, each pattern vector is associated with CP, the location where the pattern is recorded. The fingerprint patterns stored into radio map can be individual measured RSS vectors. More commonly the information of several measured RSS vectors are summarized to a pattern vector – sample mean of several RSS vectors is used e.g. in [BPR00] and [PKC02].

With probabilistic algorithms, the information of calibration data is summarized to Probability Density Functions (PDFs). For each CP, the radio map contains PDFs of measured RSS of each AP. The PDFs can be approximated using e.g. kernel functions [RMT02] or histograms [CCK01], [RMT02], [YAS03]. The histogram approximates the PDF using piece-wise constant function, where the range of the random variable is divided into non-overlapping bins; an example is shown in Figure 1-22. If the number of bins is small enough, the memory requirement with histograms is significantly lower compared to kernel based approximations and therefore these algorithms are chosen to comparison. The radio mapping for both probabilistic and pattern recognition based algorithms is shown in Figure 1-23.

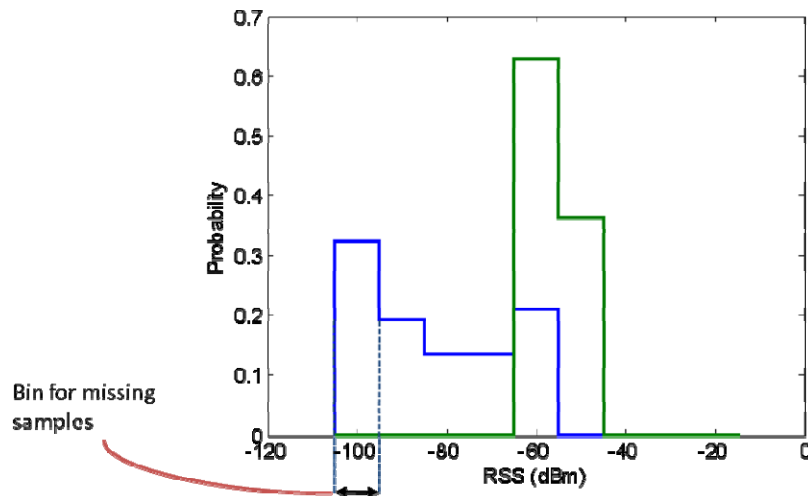

Figure 1-22: Examples of PDF approximations using histograms

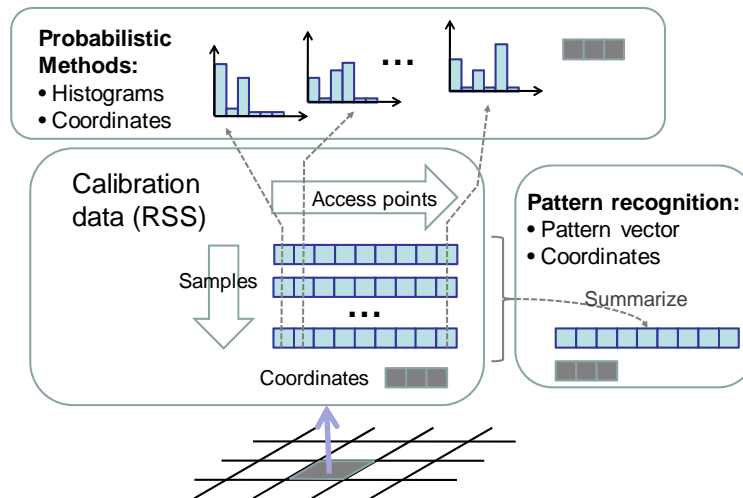

Figure 1-23: Creation of radio map

With histogram based PDFs, position estimation algorithms using e.g. ML principle [CCK01], [YAS03] or minimization of expected (distance) error [RMT02] are proposed. The granularity of estimates using ML algorithm is determined by the density of calibration point grid, whereas the estimate by minimization of expected (distance) error algorithm can interpolate between CP locations.

1.3.6 Tracking algorithms

Usually the user with its MS is moving around a certain track in different scenarios. Clearly, there are strong correlations between the positions of the MS over time. This information can be integrated in the overall position estimation process and can help to improve the estimates in average. This tracking of the MS certainly requires some kind of side-information about general mobility parameters. We focus on pedestrian navigation; hence, it is not realistic that the MS “jumps” over a far distance from one time-step to the other.

Mobility models

A good overview is given in [WHE43]. It includes general description of state space models like white noise acceleration, Gauss-Markov process velocity, or Wiener process acceleration. Additionally, random models like random walk, random waypoint, and random direction are described. Finally, models with

geographic restrictions like pathway mobility and obstacle mobility are handled. However, it has to be taken into account that the chosen mobility model is matched to the situation and also is suitable to be integrated in the chosen tracking algorithms. For instance, [KAL03] compares two algorithms that compute a path from a source point to a destination point: the Lee algorithm and the gas diffusion algorithm. The gas diffusion algorithm is better in terms of describing human paths since the Lee algorithm suffers from paths that stick to walls. On the other hand however, the gas diffusion algorithm requires more computation time. This model is further extended in [KKR+08].

Positioning Kalman Filter

The Kalman Filter (KF) [Kay93] is a general flexible tool for providing such positioning estimates in the context of tracking applications. However, the standard KF just performs optimum if several criterions on, e.g., linearity or Gaussianity, are fulfilled which is usually not the case in practical applications. Even if these conditions are not fulfilled completely, the KF gives reliable and robust estimates. The KF is a generalization of the Wiener filter, where the restriction of the Wiener filter that signal and noise are stationary is not mandatory. It is a sequential Minimum Mean Square Error (MMSE) estimator of signals embedded in noise, where the signal is characterized by a dynamical or state-space model which for the here considered case is the mobility model. If signal and noise are jointly Gaussian, the KF is the optimum MMSE estimator. The main problem of the linear KF is that it requires a linear state equation and a linear observation equation (and zero-mean Gaussian noise processes) to be optimum. Hence, one has to use the estimates from a static solution in each time-step and “smooth” them according to the mobility model and the history of the tracking filter. This approach can be denoted as Positioning KF (PKF).

The general drawback of this filter-type is the dependency on a continuous static solution in all time-steps. In practise this is not always given. Especially in the critical situations, it can happen quite often that not enough sources are available to produce a static solution. In those situations also the PKF, which relies on these intermediate estimates, cannot improve the performance or – in some situations – can be worse compared to the static solution.

Extended Kalman Filter

The main problem of the PKF is that it requires a linear state equation and a linear observation equation (and zero-mean Gaussian noise processes) to be optimum. Clearly, to track just the position of the terminal – based on recent position estimates and the mobility model – would result in such a linear relation. However, if we want to include measurements of all kinds (especially pseudo-ranges and TDOAs) that have a strongly non-linear character w.r.t. the current position, the standard linear KF is not a suitable approach to deal with this problem. A more promising approach compared to the PKF is based on EKF [Kay93]. The EKF bases on a linearization of the classical KF and gives a good trade-off between accuracy, robustness, and complexity.

Contrary to the PKF the EKF provides a joint hybrid data fusion and tracking and is able to perform as well under not-optimum conditions. For instance, the EKF still produces reliable estimates if less than the required number of sources is available. Then, the prediction based on the mobility model and the history is weighted higher. Also the situation that no source is available can be handled for a certain time. In this situation just the prediction part of the EKF is used. Clearly, the number of used sources can be varying over time and change between the different time-steps. Also this behaviour can be handled by the EKF approach inherently.

2. GNSS Receiver Simulators – State-of-the-Art

At the receiver level, in the followings we give an overview of state-of-the-art GNSS receiver simulators (or software receivers for research and development). The software Research and Development (R&D) receiver can be divided in two categories:

- Software GNSS receiver prototypes created by projects
- Commercial tools

The software receivers that are targeted only to provide navigation application (i.e. integrated to mobile device) are not discussed here. Also, the receivers clearly targeted to high end applications, like Real Time Kinematic (RTK), are out of the scope of this section.

Software receivers are of interest of both academic and industrial actors. As stated in [HDR+07] “A GNSS development tool nowadays has to be upgradeable, flexible, expandable and open when it comes to your challenges of modern GNSS signals”, which justifies the software approach.

The availability of commercial GPS/Galileo software receivers is fair. The availability of USB connections in radio front ends has been influenced positively to the popularity of both academic and commercial PC based receivers. State-of-the-art receivers are usually implementing only single frequency (E1/L1) reception.

2.1 Software GNSS receiver simulator prototypes

Five main software-based GNSS receiver simulator prototypes/projects have been found in the literature and their main features are summarized in Table 2.1 and Table 2.2.

- **IRGAL software receiver** developed between 2006 and 2008 at Mario Boella Institute and NavSas, Italy [IRG08].
- IF signal generator for Galileo and GPS (**GSNRxTM**): on-going developments at PLAN group, Calgary University (since 2004). Several versions are available: GSNRxTM (standard), GSNRx-ebTM (estimator-based), GSNRx-vbTM (vector-based), and GSNRx-utTM (ultra-tight GPS/INS) [DRI07]
- GNSS digitized IF signal simulator (**GDISS**) – on-going developments by ETRI, South Korea, since 2006 [JOO07]
- **GNSS Sim Juzzle-based**, by Silicom & CNES [GAR05], [LAT07], [ART07]
- **IpexSR SW Rx**, developed since 2002 at FAF Munich University[PAN06]

A comparison in terms of modelled signal types, used sampling frequencies, IF frequencies, number of bits in ADC conversion, CNR, bandwidth, software platform, acquisition and tracking units and navigation algorithms for all these 6 simulators is shown in Table 2.1 (first 3 simulators) and Table 2.2 (last 2 simulators).

We remark from Table 2.1 and Table 2.2 that most of these baseband receiver simulators:

- Assume a low IF or very low IF architecture (i.e., the ratio between the IF frequency and the sampling rate is less than 1),
- Typically operate at moderate-to-high CNRs (i.e., above 30 or 35 dB-Hz),
- Use FFT-based acquisition unit (unambiguous)
- No multipath mitigation algorithms are specified for the tracking stage

Regarding the ADC number of bits, there is no general rule: anything between 1 and 8 bits has been used.

The preferred software platform is C++, though couple of them use some other platforms as well.

Regarding the terms of the distribution of these software receivers, there are no clear terms of distribution. Some of them are not even available (but only used locally in the unit who developed them).

Table 2.1: Comparison of IRGAL, GNSR and GDISS GNSS simulators. N/F = not found

| Feature | IRGAL SW rx Specifications | GSNRx specifications | GDISS specifications |
|-------------|---|---|---|
| Signal type | GPS L1 & Galileo E1; MBOC not implemented | GPS L1 C/A, L1C, L2C & L5, Galileo E1B, E1C, E5A&E5B, GLONASS L1&L2; MBOC not | GPS L1 C/A, L2C and Galileo E1C&E1C; MBOC |

| | | implemented | not implemented |
|-----------------------------|---|---|--|
| <i>Sampling frequency</i> | 17.5103 MHz | 40 MHz (20MHz per I/Q channel) | 5-40 MHz (default 5.714 MHz) |
| <i>IF frequency</i> | 4.5102 MHz | User-selectable (default 10 MHz) | 1-20 MHz (default 1.134 MHz) |
| <i>CNR</i> | N/F | > = 40 dB-Hz for acquisition >= 35 dB-Hz for tracking | 30-50 dB-Hz |
| <i>Bandwidth</i> | N/F | Adjustable (default 16 MHz) | 2/4 MHz |
| <i>Quantization</i> | 1-8 bit | 3 bit (per I and Q samples) | 2-4 bit |
| <i>Acquisition/tracking</i> | Included; FFT-based acquisition; | Included; FFT-based acq.; no multipath mitigation | Not included |
| <i>Navigation Unit</i> | N/F | included | Not included |
| <i>Software platform</i> | N/F | C++ | C++ |
| <i>Drawbacks</i> | Only under Linux; not much information available regarding this simulator | Not available for general use; patent-protected; Off-line processing, huge data storage requirement for heavy sampling rate | Not much information available; rather basic simulator |

Table 2.2: Comparison of GNSS Sim and IpexSR GNSS simulators

| Feature | GNSS Sim Juzzle based | IpexSR Specifications |
|-------------------------------------|--|---|
| <i>Signal type</i> | Generic PRN codes + BOC/CBOC modulation | GPS L1, L2 & L5; Galileo signals not implemented |
| <i>Sampling frequency</i> | N/F | 40.96 MHz |
| <i>IF frequency</i> | Direct conversion architecture (?); only RF stage is mentioned | 8.087/8.287 MHz |
| <i>CNR</i> | 15-50 dB-Hz | N/F |
| <i>Bandwidth</i> | variable | 15-20 MHz |
| <i>Quantization</i> | N/F | 2-4 bit |
| <i>Acquisition/Tracking modules</i> | FFT-based acquisition; FLL/PLL/DLL tracking; dot-product discriminator | Included |
| <i>Navigation unit</i> | Not included | |
| <i>Software platform</i> | C ANSI; based on Juzzle open framework (written in Sun Java language) | C++ and assembler code |
| <i>Drawbacks</i> | Non-user friendly; based on an unconventional platform; | Not in open access; not yet developed for Galileo signals |

2.2 Commercial software GNSS receiver simulators

Commercial SW receivers have entered the market during last few years. Typically, these receivers contain whole receiver functionality, from radio hardware to navigation and application software. Receivers contain Application Programming Interfaces (APIs) for user modifications for acquisition, tracking and navigation.

Three commercial tools for Software GNSS receiver simulation can be identified. The properties of these tools are summarized in Table 2.3.

- **NordNav R30**, commercial GPS/Galileo L1 software receiver [R30], [NAV09]
- **NavX@-NSR** (IfEN), is a GPS/Galileo L1/E1 receiver with a hardware radio front end and software baseband and navigation. [HDR+07]
- **GRANADA** Galileo Bit-true Receiver Simulator developed under GARDA EU-FP6 project, Deimos [DFS+05], [FDM+04]

First two tools are full receivers for GPS/Galileo L1 band, offering limited access to receiver functions through Application Programming Interfaces. The last tool is not a fully functional receiver, since it does not contain a navigation unit.

Table 2.3: Comparison of commercial software GNSS receiver tools

| Feature | NordNav R30 specification | NavX®-NSR (IfEN) specification | GRANADA Specifications |
|-------------------------------------|--|--|--|
| <i>Signal type</i> | GPS/Galileo L1 | GPS/Galileo L1 | GPS L1, Galileo E1, E5A, E5B & E6; MBOC not implemented |
| <i>Input possibilities</i> | RF, injection of simulated signals possible | RF | Simulated signals |
| <i>Operating modes</i> | Real-time, post-processing | Real-time, post-processing | Post-processing |
| <i>Sampling frequency</i> | 16.367 MHz | 23.1 MHz | >= 40 MHz (default 93.33 MHz) |
| <i>IF frequency</i> | N/F | 4.35 MHz | Related to sampling frequency (default 70 MHz) |
| <i>CNR</i> | N/F | Acquisition sensitivity 25 dBHz (-149 dBm) Tracking sensitivity/ Vector acquisition sensitivity 10 dBHz (-164 dBm) | > 35 dB-Hz (default 49 dB-Hz) |
| <i>Bandwidth</i> | N/F | 10 MHz (RF) | 40 MHz |
| <i>Quantization</i> | 1,2, or 4 bits | 1.5 bit (4 and 8 optional) | 1-8 bit (default 8) |
| <i>Acquisition/Tracking modules</i> | Configurable acquisition parameters Variable code and carrier tracking loops 24 channels | Fast acquisition (FFT) Baseband APIs enables implementation of user's own acquisition and tracking routines and loop parameters | Included (encrypted algorithms) |
| <i>Navigation unit</i> | Included | Included | Not included |
| <i>Software platform</i> | MS Windows XP environment | MS Windows XP environment (C++) | Simulink |
| <i>Drawbacks</i> | Software not open access; offers API for external tracking loop controlling At 2007 NordNav was acquired by Cambridge Silicon Radio (CSR) and R30 is not available in their product portfolio | Software not open access; offers APIs for; IF Sample Data Access, Baseband Extension, and Navigation Extension | Expensive licenses, partially encrypted sources, not very suitable for algorithm development, moderate flexibility, rather slow simulation times |
| <i>Price</i> | N/F | N/F | Around one or few tens of thousands of EUR/license (depending on end user) |

2.3 Academic software GNSS simulators

During last years, the availability of GNSS radios with USB interface has been improved. With this kind of devices the GNSS signal is very straightforward to capture into a PC for post-processing, e.g. to Matlab software. Basically, any existing commercial front end can be updated to have USB feature.

The availability of USB GNSS front-ends has also influenced to the development of academic receivers, which are not so closely tied to a certain radio front-end. Matlab environment offers a good environment to build post processing receiver applications and current PC's are powerful enough to perform GPS receiver measurements and navigation software even in real time.

Typically, academic receivers have no dedicated APIs implemented, but they offer full access to source codes. When comparing to commercial simulators, this allows higher degree of freedom in implementation of new algorithms but it might also make the implementation process more complex.

2.3.1 A software-defined GPS and Galileo receiver

This receiver is a Matlab code that comes with a book [BAB+06]. The book contains a DVD with Matlab codes and few example data sets. The receiver is accompanied with a radio front end module manufactured by SiGe, which is available for purchasing through book's webpage [CCA09]

In principle the receiver should also work with other radios, which are capable to store the raw data to a hard disc for post processing.

The included Matlab codes have open access, and, thus, the user can modify them to test different algorithms, sampling frequencies, bandwidths, etc. By default, the receiver supports GPS L1 and Galileo In-Orbit Validation Element (GIOVE) A signals. [BAB+06]

A USB radio front-end manufactured by SiGe is offered to complete the book and software receiver [BAB+07]. The packaged radio is based on SiGe's SE4110L GPS Front End Application-Specific Integrated Circuit (ASIC) and has USB output providing digital signal with following characteristics [CCA09]:

- Sampling frequency: 8.1838 MHz
- Intermediate frequency : 38.400 KHz
- 2bit I/Q samples (1bit I & 1bit Q) in a char binary format (sI0, sQ0, sI1, sQ1, sI2, sQ2, ..)

Still, the receiver should work with other radios also. It reads the raw data from file and it thus independent of the data source, if the data format is suitable for the receiver.

2.3.2 C++ TUTGNSS

This software receiver created in Tampere University of Technology runs in a laptop in a Windows environment. In uses individual threads for processing of input buffering, acquisition, and tracking channels. First version supports GPS L1, and is capable for real-time processing with used SiGe SE4120L GPS (+Galileo Ready) L1 front end. [RHN09]

The receiver can read raw data from both; pre-recorded data from file and digital stream from radio front-end. The first version of receiver is supporting only SiGe front-end, but it is extendable to work also with other front-ends.

3. State-of-the-Art High-End Professional GNSS Receivers

In Chapter 5 of D1.1 Market Definition and Core Technology Report, different technologies available currently in state-of-the-art high-end professional GNSS receivers were summarized. A short table analyzed the likelihood of these technologies to become commercially available in mass market GNSS receivers between 2012 and 2015. After reviewing data sheets of professional GNSS receiver manufacturers (Trimble, Javad, Magellan, Navcomtech, NovAtel, Leika, Septentrio, Topcon), Table 3.1 presents an extended summary of the results in D1.1. The subsequent sections of this chapter present more details on the technologies in Table 3.1.

Table 3.1: Overview on technologies commercially available in state-of-the-art high-end professional GNSS receivers

| Technologies/Features | Example Products and Performance Values |
|---|--|
| High Sensitivity | Trimble R8, Javad Triumph |
| High Accuracy, e.g., carrier tracking | Magellan BLADE, Trimble R8; Navcomtech <1mm; Leika <0.2mm rms |
| Post processing | Magellan BLADE- BLADE can be run forward and backward many times to achieve post-processing performance that is better than real-time performance |
| Differential GPS | Magellan BLADE, Trimble R8, Leika GS20 |
| WAAS/SBAS/EGNOS/MSAS Support | Magellan BLADE, Hemisphere GPS |
| Multipath mitigation & advanced algorithms, e.g., RTK | <p>Magellan BLADE:</p> <ul style="list-style-type: none"> Instant RTK Long Range RTK Effective RTK in shaded areas DG14: Edge and Strobe correlator <p>Trimble R8, Leika GS20, Javad Triumph:</p> <ul style="list-style-type: none"> Code Differential Base Multi-Base Code Differential Rover Advanced Multipath Reduction In-Band Interference Rejection RAIM <p>Septentrio</p> <ul style="list-style-type: none"> A Posteriori Multipath Estimator (APME) RAIM <p>Navcomtech</p> <ul style="list-style-type: none"> Multipath rejection <p>Novatel</p> <ul style="list-style-type: none"> Multipath Estimating Delay-Lock-Loop (MEDLL) |
| Multiple antenna support | Javad Triumph |
| Increasing channels in parallel | Trimble R8 (220 Channels) Javad Triumph (216 Channels) |
| Faster update rates (up to 100Hz) | Javad Triumph: Update Rate 1Hz, 5Hz, 10Hz, 20Hz, 50Hz & 100Hz |
| Multi frequency support | Trimble R8, ... |
| Multi system support (GLONASS, GPS, GALILEO) | <p>Magellan BLADE</p> <p>Trimble R8:</p> <ul style="list-style-type: none"> GPS: L1C/A, L1C, L1E, L2C, L2E, L5 |

| | |
|--------------------------|--|
| | <ul style="list-style-type: none"> • GLONASS: L1C/A, L1P, L2C/A (GLONASS M only), L2P • SBAS: L1C/A, L5 • Galileo GIOVE-A and GIOVE-B Septentrio Javad Triumph: <ul style="list-style-type: none"> • GPS L1/L2/L2C/L5 • Galileo E1/E5A • GLONASS L1/L2 • SBAS Topcon: <ul style="list-style-type: none"> • GPS L1 L2 & L5 carrier, L1 CA, L1 P, L2 P, L2c • GLONASS L1, L2 & L5 carrier, L1 CA, L2CA, L1 P, L2 P • Galileo E2-11-E1, E5, E6 |
| CPU | Xscale PXA320 (806MHz), Xscale PXA270 (624MHz), Xscale PXA255 (400MHz), ARM920T |
| Time To First Fix (TTFF) | Cold < 38s, Warm <10s, Reacquisition<1s |
| Raw data | Navcomtech Septentrio: Code, carrier, SBAS, navigation data JAVAD, Topcon: Code, carrier |
| Dynamics | Navcomtech, Novatel <ul style="list-style-type: none"> • Acceleration 6g, max. speed 515m/s, max altitude 18.3km |
| Power | Novatel >1.4W; Topcon, Javad, Septentrio > 1.2W Single Frequency: Magellan A12 sensor, Trimble 1W, Magellan A12 OEM board 230-250mW, Trimble Copernicus II 120mW, Copernicus 83mW |
| Other sensor | NovAtel INS/IMUs |

3.1 Differential GNSS (DGNSS)

Basically there are several types of errors observed when estimating the pseudo range of GNSS signals. One error term is systematic, which means that the observed error is constant for a certain area and time. Strong spatial correlations are exploited with the DGNSS principle. A reference GNSS station, whose position is exactly known, additionally determines its position using GNSS signals. Comparing the estimation result with the true position allows determining systematic deviations. Such deviations are caused for instance by ionospheric signal delays, satellite clock errors, orbit errors, etc. Since these errors are spatially and temporarily correlated, GNSS receivers which are sufficiently close to the reference station will observe the same systematic error. The reference station provides its estimation about that systematic error to surrounding GNSS receivers. These receivers will subtract that error from their own position estimation and, therefore, eliminate the systematic error term. Two strategies for DGNSS are possible

1. Online: A reference station provides correction data (i.e. the systematic error) within its coherence time to DGNSS capable receivers via an appropriate data link.
2. Offline: A GNSS receiver stores its position/pseudo range estimates together with time stamps. Access to a data base, which contains time stamped systematic error values, allows processing the GNSS receiver's data offline.

3.2 Carrier phase tracking

GNSS receivers are capable to estimate the code phase of a GNSS pseudo random signal within some percent of the chip duration, which is in the range of several meters for the GPS C/A signal. Lower chip

durations therefore yield higher accuracy. Lower chipping rates coincide with higher signal bandwidths. Using the GNSS signal carrier itself provides an even higher signal bandwidth. GNSS carriers are located in the L-Band. The wavelengths for these carriers are 20...30 cm. Compared to the pseudo random signal bandwidth, the carrier frequency is higher by a factor of 10...100. This yields achievable accuracies in the millimetre range. However, ambiguity in carrier phase tracking occurs in integer multiples of the carrier wavelength. To resolve these ambiguities and for proper signal acquisition it is necessary to exploit a signal part, which has wavelengths respectively signal bandwidths between the chip rate and the carrier. Such a signal is usually the difference of two L-Band GNSS signal carriers.

3.3 Real-time kinematic (RTK)

RTK is a differential positioning technology related to carrier phase tracking. Like in the DGNSS technology, where correction data related to code phase measurements are being transmitted, RTK uses a real time data link from an RTK reference station to an RTK receiver for transmitting correction data for carrier phase measurements. Ranging errors at the reference station and a mobile receiver decorrelate with increasing distance. This limits the coverage area of a RTK reference station to approximately 10 km. The concept of network RTK overcomes this limitation. Here a network of reference stations provide a sample of the systematic error over the covered area. Using interpolation methods, correction data for a Virtual Reference Station (VRS) in the vicinity of the mobile RTK receiver can be calculated and transmitted to that receiver.

The achievable accuracy using RTK technology is in the sub millimetre range and, therefore, sufficient for geodesy applications for instance.

3.4 Carrier smoothing

The challenge for carrier phase tracking is to resolve carrier phase ambiguities. The carrier wavelength in the L-band is in the range of 20...30 cm. This significantly smaller compared to the resolution of the code phase ambiguities, which are in the order of some hundreds of kilometres. To resolve the number of wavelengths between the satellites and the receiver, an initial ranging accuracy in the order of the wavelength is required.

However, carrier phase pseudo range measurements still provide a variance which is significantly smaller compared to the code phase variance or jitter, even if ambiguity cannot be resolved. This can be exploited in tracking algorithms. Pseudo range measurements, in particular their differences, at different time instances can therefore be related to each other by the much more accurate carrier phase range measurements. This technology is referred to as “carrier smoothing” or “carrier aided smoothing”.

3.5 Multi frequency receivers

The basic measure for GNSS positioning are signal propagation times. To calculate distances, the signal propagation speed is required. Since electromagnetic waves travel through the atmosphere, this propagation speed differs from the vacuum speed of light. Propagation in the troposphere is non-dispersive and hard to estimate. In the ionosphere, the propagation speed is dispersive, i.e., dependent on the frequency. Using a two-frequency receiver and exploiting the known relation of the dispersion, the ionospheric errors can be estimated and corrected.

3.6 Assisted GNSS

Navigation receivers require data about the state of the satellites itself, e.g. orbit data. This information is transmitted by the satellites at a rather low data rate. The assisted GNSS (A-GNSS) technology provides this data by mobile radio links (GSM, GPRS, UMTS, High-Speed Downlink Packet Access (HSDPA)). From such data, an A-GNSS receiver is able to estimate parameters, like the Doppler shifts of the satellites' signals, which significantly decrease the acquisition time and, therefore, the time to first fix. To use A-GNSS, a GNSS receiver requires mobile radio communication capabilities.

3.7 Satellite based augmentation systems

Satellite based augmentation systems (SBAS) provide correction data for wide areas. Systems like the US WAAS (Wide Area Augmentation System) or the European EGNOS (European Global Navigation Overlay System) usually supply continental regions. Monitoring stations on ground generate and compile correction data and provide this data to SBAS capable receivers via a satellite link. An SBAS data link itself is provided by a transponder on a geostationary communications satellite. Currently these systems supply GPS. For data transmission SBAS systems use GPS conform modulation, i.e., data is transmitted

in the L1 band using code multiplex. Transmitting in the same bands and using the same type of spreading code as the GNSS itself reduces the additional hardware effort in GNSS receivers.

Augmentation systems enhance the accuracy of GNSSs by providing correction data. In such systems, *Ranging and Integrity Monitoring Stations (RIMSSs)* receive the signals, transmitted from navigation satellites. Because of their known position, the received GNSS signals can be assessed with respect to their “health”. Integrity information, e.g., in form of horizontal or vertical protection levels (HPL, VPL) is calculated and provided to the end receivers in addition to positioning correction data. System integrity is an important information for safety critical applications, e.g., safety-of-life receivers used for future aeronautical navigation services. Location based services, which require a specific quality of service (QoS), are another field in which reliability of positioning becomes more and more important. Automatic payment systems like road toll collecting are an example for such applications which require QoS guaranties.

3.8 RAIM

For safety-of-life applications information about reliability, correctness or integrity of the signal is required. Receiver Autonomous Integrity Monitoring (RAIM) is a technology which generates such integrity information at the receiver. It aims to identify satellites which cause significant deviations in the estimated position. RAIM uses redundancy in the available measurements by calculating position solutions for subsets of the visible satellites and comparing these solutions against each other. In case one subset of the satellites provides a significantly different position solution, this set of satellites likely contains a corrupted one. RAIM is a receiver based technology and provides integrity information without any external augmentation system.

3.9 Multipath mitigation high-end receivers

3.9.1 Maximum likelihood based approaches: Multi-correlator based code tracking

Compared with the conventional EML tracking loop, where only 3 correlators are used (i.e. Early, Prompt and Late), in a multi-correlator based structure, a bank of tens of correlators are employed, with the purpose of allowing more efficient signal processing on the correlation function [BHL+09]. Multi-correlator based code tracking is a generic name that encompasses all the delay estimation algorithms which make use of multiple correlator banks, such as Peak Tracking [BLR08], multiple gate delays and deconvolution algorithms. The Peak tracking algorithm studied in [BLR08], [BHL+09], and shown to have the best performance among the considered multipath mitigation approaches is based on the idea that, by weighting the local peaks delays with some weights depending on the previous LOS delay estimate, on the path separation between estimated delays of the local peaks in the correlation function, and on their relative amplitudes, we can estimate the most likely candidate for LOS delay.

The problem with the multi-correlator-based code tracker is that their complexity is proportional to the number of correlators used to estimate de delays. Since the best performance is achieved with typically few tens or hundreds of correlators, their complexity might be prohibitive.

3.9.2 Deconvolution approaches

Deconvolution methods are means of inverse filtering. In order to reduce the noise enhancement effects, inherent to the inverse filtering, constrained inverse filtering methods can be employed. These methods are constrained in the sense that they do not allow the output values to lie outside some predefined set or in the sense that the inverse operator is never completely formed, but only approximated iteratively. Among the constrained inverse filtering methods, the best known ones are the Least-Squares (LS) techniques and the Projection Onto Convex Sets (POCS) algorithms. LS and POCS have been studied in the context of Galileo code tracking in [LLR06]. It was shown in there that LS fails to work in the presence of noise and multipaths, but POCS algorithm gave good results, similar with the Teager-Kaiser estimator. The complexity issues in deconvolution approaches are one of the main impediments of making use of these algorithms in commercial receivers. However, methods to decrease the complexity of deconvolution approaches are useful to be searched for.

3.9.3 Sequential Bayesian estimation

We may also solve the time variant multipath mitigation problem using EKFs or Particle Filters (PFs) instead of using the approach to determine a CRMM. Again, the observation vector in the receiver algorithm assumes the superposition of certain multipath components and tries to estimate and adjust

them for all time instances. The EKF comprises the prediction and filtering step and propagates iteratively the expected value of the state vector and the error covariance matrix.

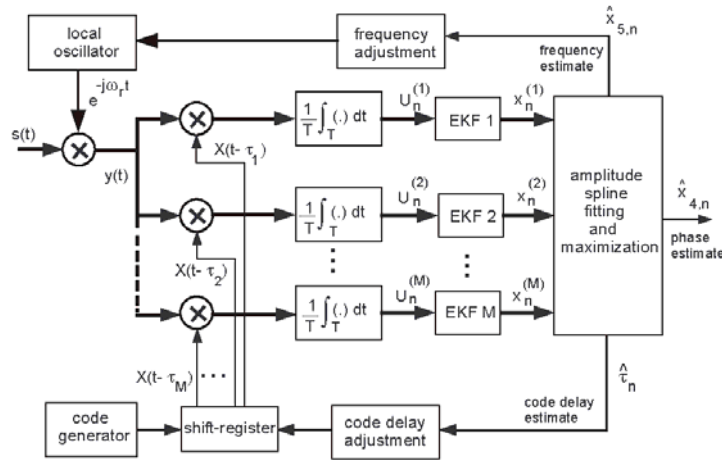

Figure 3-1: Model of a sequential Bayesian estimator [NSL05]

3.9.4 Vision correlator

The vision correlator developed by NovAtel Inc.'s is a novel method of code synchronization which is significantly different from the EML code tracking structure. We obtain as a main advantage of the vision correlator the ability to decrease the positioning errors due to multipath below the performance of the NEML correlator. The vision correlator incorporates a Multipath Mitigation Technique (MMT) by estimating the delay, amplitude and phase dependent on the array of inphase and quadrature phase samples measured at discrete code phase offsets along the expected chip function. This algorithm resembles the methods developed in GREAT concerning the CRMM, because the complexity reduction resorts to a bank of delay-shifted Code Matched Correlators (CMCs) and the estimation process is optimized according to ML theory. In particular, elements like the LS amplitude estimation appear also in both algorithms.

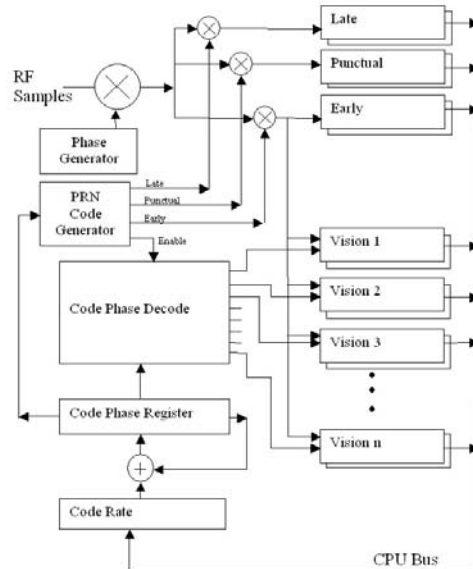

Figure 3-2: Extension of vision correlator beginning from EML code tracking structure [FJ05]

3.10 Interference mitigation

First, we focus on baseband solutions for narrowband interference rejection. The main algorithms found in the literature in order to mitigate/cancel the narrowband interference can be grouped into linear and non-linear filtering approaches:

- Linear filtering-based solutions:
 - Based on Kalman filter
- Non-linear solutions:
 - Time-domain based approaches: approximate conditional mean filtering [RP94], enhanced nonlinear adaptive filtering [SP03], or adaptive lattice predictor architecture [MAO08]. In these approaches, the performance is highly dependent on the CNR and often fails under rapidly time-varying interference.
 - Frequency domain based interference mitigation [AMI97]: they are typically suitable only for static narrowband interferers.
 - Time-frequency domain based interference excision [AMI97]: they combine the advantages of time-domain and frequency-domain approaches, at the expense of an increased complexity.
 - Wavelet-based interference mitigation: The Discrete Wavelet Transform (DWT) or the Gabor transform is applied to the data, and the coefficients of high energy are removed prior to the inverse transform [MSD94], [LML08]. The DWT is appropriate for cases of pulse jamming or interference with burst characteristics.

Another classification of narrowband interference algorithms, in terms of spatial versus temporal processing and pre-correlation versus post-correlation approaches can be found in [SHA07].

Adaptive notch filtering and frequency excision techniques are examples of pre-correlation techniques. Post-correlation techniques usually refer to adaptive code/carrier tracking loops, which utilize INS aiding data from external sensors such as IMUs [SHA07].

A comparison in terms of performance and complexity of these algorithms is not yet available in the literature. A comparison in terms of advantages and disadvantages of pre-correlation interference mitigation techniques can be found in [LCB98]. Based on the study in [LCB98], the lowest-cost solution for narrowband interference based on pre-correlation is the fixed frequency filtering. However, this approach does not deal well with in-band interferers

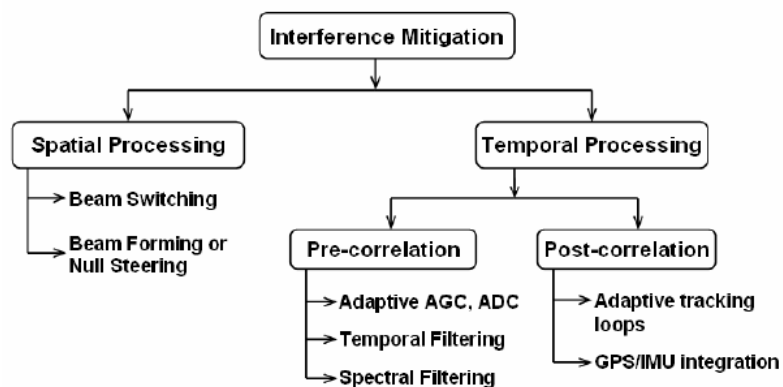
**Figure 3-3. Classification of GNSS narrowband interference mitigation techniques**

In terms of wideband interference cancellation methods, array signal processing techniques are typically proposed. These techniques can efficiently suppress the above interferences according to the spatial information, but requires the use of multiple antennas [LFW06].

3.11 Dual/multi-frequency architectures

A summary of the existing dual and tri-band frequency GNSS commercial receivers nowadays is shown in Table 3.2 and Table 3.3, respectively. The main information about the GNSS manufacturers shown in these tables was found in [GPS08], [GPS09].

The information about the multipath mitigation techniques likely to be used in some of the receivers (where this information is not specified) comes from searching (in the patent databases) for multipath mitigation techniques belonging to the corresponding manufacturer. In the last column of Table 3.2 and Table 3.3, we only showed the multipath mitigation implemented in baseband domain (as opposed to those techniques implemented in measurement domain). We also note that the list may be not exhaustive, and the names of the multi-frequency receivers are only some examples and may not cover the full range of the manufacturer multi-frequency products.

Table 3.2: Commercial dual-frequency GNSS receivers (when not specified, both code and carrier phase measurements are supported). N/F = not found.

| <i>Name</i> | <i>Company</i> | <i>Frequencies</i> | <i>Notes</i> |
|---|----------------|--|---|
| UZ-12 | Ashtech | GPS L1 (code and carrier phase), L2 (carrier-phase only) | Multipath mitigation (not specified); it is likely to be based on strobe correlator [GR97], [VZZ98] |
| DGRx | DataGrid | GPS L1 (code and carrier phase), L2 (carrier-phase only) | Multipath mitigation (not specified) [GPS08] |
| Navx@-RPS | Ifen GmbH | GPS L1, L2, L5 Galileo E1, E5a/b | N/F |
| Embedded GPS receiver | ITT A/CD | GPS L1, L2 | No multipath mitigation |
| Delta G3T | JavadGNSS | | |
| Eclipse R220 | Hemisphere GPS | GPS L1, L2 (carrier only) | N/F |
| ProFlex500 [Mag] | Magellan | GPS/GLONASS/SBAS L1, L2 | ‘Advanced multipath mitigation’ (not specified); it is likely to be based on strobe correlator /gating functions [VZZ98], [ZVN02], [GZV01] |
| NCT-2030M | NavCom | GPS L1, L2 | Patented multipath rejection method based on gating functions [WOO01] |
| HAGR | NavSys | GPS L1, L2 | Code multipath reduction based on beam steering |
| OEMV-2/3/4 EuroPak-15a | Novatel | GPS L1,L2 Galileo E1/E5 | Multipath Estimating Delay Locked Loop (MEDLL) and/or Pulse Aperture Correlation (PAC) multipath mitigation |
| HiPer M | TopCon | GPS L1, L2 | ‘Advanced multipath mitigation’ (not specified); ; it is likely to be based on strobe correlator/gating functions [VZZ98], [ZVA02] |
| PolaRx2e PolaRx2C PolaRx3TR PolaRx3G | Septentrio | GPS L1, L2 GPS L1, L2C GPS/GLONASS L1, L2 GPS/Galileo L1/E1, L5/E5a | A Posteriori Multipath Estimator (APME) on all considered frequencies [SLE01] |

Table 3.3 Commercial tri-band frequency GNSS receivers (when not specified, both code and carrier phase measurements are supported)

| <i>Name</i> | <i>Company</i> | <i>Frequencies</i> | <i>Notes</i> |
|-------------|----------------|--------------------|---|
| GPS1200+ | Leika | L1, L2, L5/E5 | Likely to use narrow correlator & ... Check status (if commercial or under research): see reference 7 below |

| | | | |
|-------------|------------|---|---|
| 8305HP | Omnistar | L1, L2/L2C (carrier only), L5 prepared (carrier only) | 'Everest TM multipath rejection' algorithm from Trimble (detailed description not found) |
| GeNeRx | Septentrio | GPS L1, L2P and L5 Galileo E1, E6, E5a,b | A Posteriori Multipath Estimator (APME) on all considered frequencies [SLE01] |
| GSR2700IS X | Sokkia | GPS L1, L2, L5 and GLONASS L1, L2 | Pulse Aperture Correlation (PAC) and Vision Correlator multipath mitigation |
| R8 | Trimble | GPS L1, L2 (phase only) and L5 (phase only) plus GLONASS L1, L2 | Multipath mitigation based on choke ring antennas and strobe correlators |

We recall that the strobe correlator and the Pulse aperture correlator, which seem to be the structure of choice for most of the multipath mitigation algorithms in nowadays GPS receivers, are, in fact, referring to the same structure, also known as the High Resolution correlator or the Double-Delta correlator.

3.12 Professional receivers front-ends

As far as the professional receivers front-end in general no detailed information is provided on the solution adopted. In general this kind of products serve the high-end “commercial” market and the customers have different priorities if compared with the mass market, and they are usually put in the following order: 1st accuracy, 2nd robust tracking, 3rd cost, 4th power and finally time to first fix.

For these reasons the solution which are usually adopted in professional receivers are based substantially on the replica (in case of multiple frequency reception) of single heterodyne chains built-up by commercial COTS. The results are OEM boards with dedicated processor, matched to the specific requirement. With this approach, the performance of each chain can be adjusted to the relative BandWidth (BW) requirements, obtaining very good signal quality at a reduced price. The drawback is the size and power consumption, but as this are not strict requirements (in generally size is not a constraint in professional applications); they not constitute severe problems in this kind of implementations.

Performance and architecture of professional receivers' front-end are usually not available; few examples are illustrated in pictures below. In Figure 3-4, one of the Javad OEM multi frequency board is presented. As can be noticed, the RF section on the left seems based on the repetition of three RF chains. Also in one of Magellan solution (Figure 3-5) it seems clear that the two RF sections are housed in separate boxes and occupy quite a lot of PCB space.

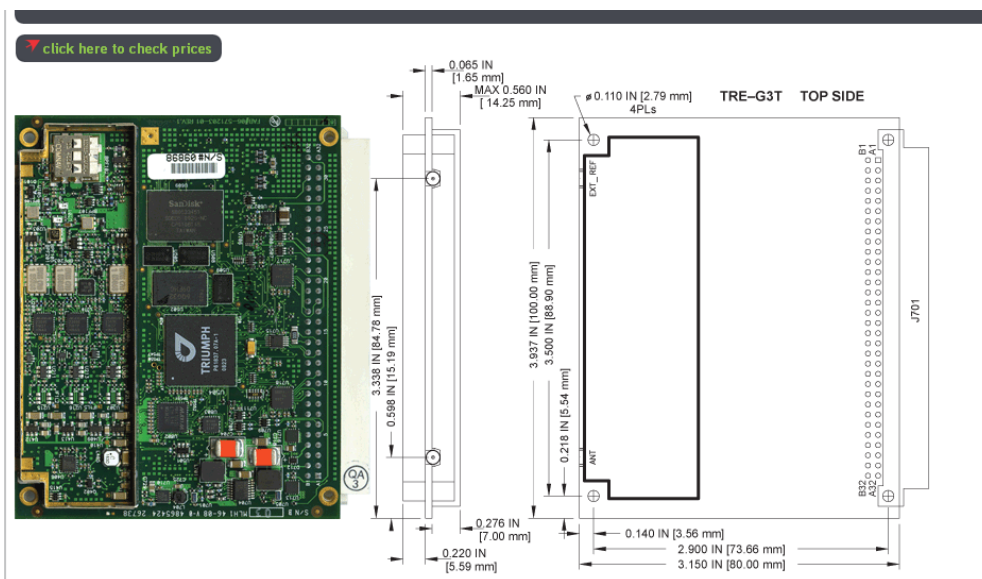

Figure 3-4: Picture and dimension of the Javad TRE-GT3 board for multi-band operation



Figure 3-5: Image of the Magellan MB500 dual-frequency board

One example of GNSS receiver for professional application which has been reported in literature is the Broadband front-end which should have been developed by Nemerix in the frame of the GJU ARTUS project [ART08]. The receiver front end architecture is based on a conventional super-heterodyne architecture with RF and IF external filters, and a final 15MHz Low pass filter, (Figure 3-6) to allow an overall 30MHz receiving bandwidth.. However it is not clear if this broadband receiver chip has been fabricated yet.

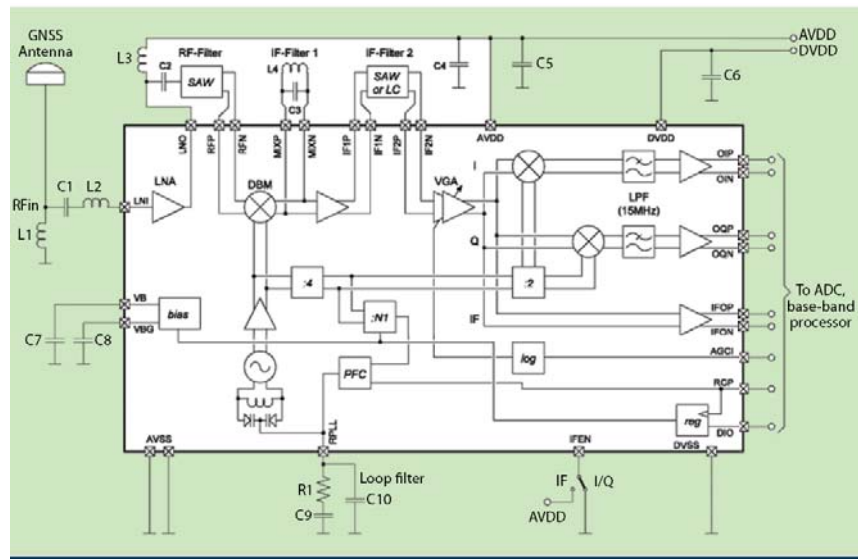

Figure 3-6: RF ASIC front end to be developed in the frame of the ARTUS project

A mention should be given to the Zarlink GP2015 GPS receiver front end (Figure 3-7). It is based on a triple conversion architecture with external filters drawing quite high current of 70mA at 3V supply. It is a quite old product and its performances are not so good, but it has been used and is still used in some professional and experimental research receivers. An example is given by the NAMURU receiver [NAMU06] for scientific applications.

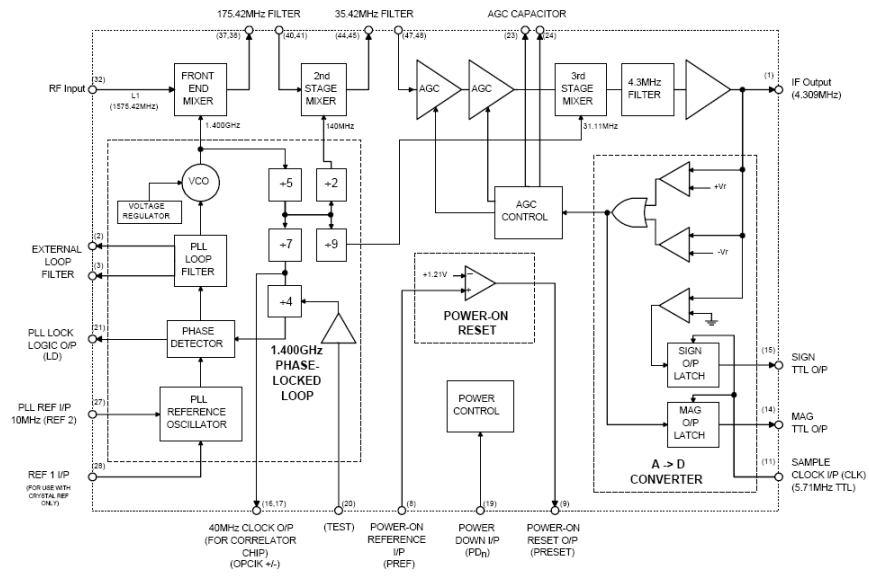

Figure 3-7: Block Diagram of the GP2015

4. Technology Gaps: Conclusions

In D1.1 Market Definition and Core Technology Report, the key core technological drivers were presented and the following key core technologies were identified:

- Integration of GNSS with other sensors, communication systems, and A-GNSS
- Advanced algorithms, e.g., multipath mitigation
- Multi-GNSS receiver
- Multi-frequency receiver
- Low power consumption

As TUT's receiver platform has been developed for GPS signal reception and will be extended to Galileo signal reception in the GRAMMAR project, GRAMMAR will inherently investigate a multi-GNSS receiver. The integration of GNSS with other sensors and communication systems has been discussed in Section 1.3. The integration with A-GNSS (cf. Section 1.3.2) is not an explicit research topic in the GRAMMAR project, but was investigated in the GREAT project [19]. Hence, it should be in principle straightforward, to extend the results from GREAT and we plan no further investigations on this issue. As the multi-frequency receiver technology has a strong influence on power consumption and advanced algorithms, part II of D1.1 presents the multi-frequency receiver and where applicable addresses power management issues and advanced algorithms. To conclude, we identify technology gaps in the sequel given D1.1 and the previous chapters of this deliverable.

4.1 RF front end

Following the considerations in Section 1.1, it appears clear that in order to allow the implementation of an advanced receiver front end capable to match with the targeted requirements (cf. D1.2 Requirements and Receiver Specifications) the following technology gaps should be addressed in the implementation phase:

- Find best compromise between performance and power consumption to match with the mass market requirements, and select best architecture
- Optimize the BW
- Really Flexible multi frequency solution (to match with terminal requirements)
- Linearity performances
- Cope with Galileo signals (all solution are only GPS)

4.2 Base band

4.2.1 Baseband receiver architectures

4.2.1.1 Acquisition and tracking units

To summarize the discussion from Section 1.2.1, the following technology gaps regarding the acquisition stage have been found:

- No study regarding the optimal dwell structure (single, double, triple ...) has been found with respect to MBOC-modulated Galileo signals. The choice of the multi-dwell architecture is an open issue.
- The various studies of different FFT-based acquisition structures found in the literature do not give a concluding answer with respect to the best option in terms of complexity and accuracy. The choice is still to be made between structures with partial code correlation and full code correlation, and also between structures which take into account the data bit transition for data channels and those who ignore the data bit transitions.
- The choice of the decision statistic in acquisition stage is not well documented for Galileo signals, and, in particular, for MBOC-modulated signals.
- The best combination scheme between pilot and data channels from the acquisition point of view is still an open issue in GNSS-related papers, as emphasized in Section 1.2.1. Moreover, the data and pilot combining for the tracking stage seems not to be addressed so far in the literature. The tradeoffs between implementation complexity and performance should be taken into account when selecting the best combining method.
- The optimal selection between the unambiguous and ambiguous acquisition methods for Galileo receivers is still an open issue. The optimality criterion should consider both the performance enhancements and the complexity.

- Alternative solutions to achieve high sensitivity (besides increasing coherent and non-coherent integration lengths) are hard to be found in the literature.

With respect to the code tracking stage, despite the fact that many multipath mitigation solutions have been proposed in the literature so far, there is a significant lack of comparison studies between different proposed algorithms. Unified solutions, valid in a wide range of scenarios (e.g., various CNRs, various multipath profiles), are still to be found. Additionally, specific gaps with respect to the discussions from Sections 1.2.1.2 and 3.9 are:

- Optimization of MGD structures in the context of MBOC modulation
- Feasibility of Teager-Kaiser-based algorithms in the context of Galileo (and MBOC), including bandwidth limiting effects
- The NEML code tracking structure may also be used for time variant channel models to determine the tracking jitter. However, once these time variant channels are considered, it is of particular importance to determine besides the tracking accuracy the probability of a loss of lock. Therefore, we need to look at the MTLL. Large MTLL values provide a large robustness against the loss of lock which requires a reacquisition procedure. The conventional EML structure allows only optimizing one criterion: We get a large MTLL and a large tracking accuracy, or a small MTLL and a small tracking accuracy.
- The transition to time variant multipath mitigation which allows eliminating multipath errors also for realistic channel models is inevitable. We observed in the results in GREAT that long observations which are needed to enhance the SNR cannot be processed correctly any more. Therefore, we develop algorithms which perform the channel delay estimation also for time variant channels and offer the processing of several hundreds of codewords. Clearly, all the components of the CRMM signal processing methods need to be adapted to the enhanced time variant channel modelling including the complexity reduction.
- The processing of time variant channels enforces also the investigations of low complexity adaptive code tracking algorithms. We need to investigate in particular extensions of code tracking algorithms by elements of the time variant multipath mitigation and how the MTLL may be enlarged and the tracking jitter can be decreased.

Regarding the carrier tracking stage, the following questions seem not to have a good answer so far in the context of Galileo receivers, based on the literature overview:

- The choice between FLL-only, PLL-only and FLL-aided PLL loops
- The choice between single-link carrier trackers and multi-link carrier trackers (such as Kalman filters). However, for mass-market applications, the single-link carrier trackers seem the only possibility, because the other solutions are much too complex.
- The parameters of the optimum discriminator and loop filter to be used in carrier tracking when single-link carrier trackers are employed (i.e., individual PLL/FLL for each satellite to be tracked)

4.2.1.2 Multi-frequency architectures

As seen in the above two sections, the majority of the current multi-frequency receivers offer code tracking capabilities only on one frequency (L1); for the other frequency bands, typically only the carrier-phase tracking is offered. Code tracking in multi-frequency architectures is an open issue that has still to be addressed.

The advantages of dual-frequency receivers reported so far in the literature are two-folds:

- Ionospheric errors (inherent in all GNSS observations) can be modelled and significantly reduced by combining satellite observations made on 2 different frequencies
- Observations of two frequencies allow for faster ambiguity resolution times and for the use of ‘On-The-Fly’ (i.e., in the motion) technology, used for kinematic surveys

However, the advantages (if any) of dual-frequency combinations in the context of code tracking have not been studied/reported so far.

4.2.1.3 Interference mitigation

The performance deterioration with and without interference cancellation methods, under various interference scenarios is poorly documented for Galileo signals, and especially, for MBOC-modulated signals. Such analysis is important in that it should give an idea whether the additional complexity coming from the interference cancellation blocks is justified by the increase in performance.

Especially, from the point of view of mass-market receivers, the narrowband and wideband interference mitigation algorithms proposed so far in the literature might be too complex to be incorporated. One promising approach to be considered in the continuation is the differential correlation.

Another issue not well covered in the GNSS literature is the issue of measuring the level of narrowband interference from the received baseband signals (so that we can use only the unaffected carrier frequency in a dual-frequency architecture).

4.3 Hybrid data fusion

4.3.1 Hybrid data fusion with cellular communications systems

Although many of these methods have been studied intensively, today's implemented fusion algorithms seem to have more a loose character of data fusion. So there seems to be no fusion on pseudo-range/TDOA level. The systems can just provide different position estimates for the various approaches (e.g., based on cell ID, TDOAs, GNSS) at the same time. But the fusion itself can only be done at position level. From the global view this fusion is not optimum since a lot of information is dropped during the loose coupled fusion process. A tight coupling of the fusion would be more beneficial here.

Additionally, effects like Non-LOS (NLOS) propagation should be handled in a joint way considering the complementary systems of GNSS and cellular communications. This will help in terms for detection and mitigation strategies. An essential part of NLOS mitigation is the NLOS detection, i.e., the identification of satellites or BSs that are under NLOS. This usually can only be done on the physical or signal processing layer. This information has to be provided afterwards to the hybrid data fusion entity, where the knowledge of NLOS status can be exploited (e.g., in terms of different weightings). Initial investigations started in [GRE08] have shown that this knowledge is quite beneficial compared to RAIM-like solutions, where only redundancy of several links can be exploited. However, for the combination of NLOS detection and mitigation a strong coupling between the signal processing and hybrid data fusion layer is necessary. Furthermore, the combined consideration of cellular system and GNSS would allow the use of an increased number of sources. Within the GRAMMAR project, the NLOS detection and mitigation is a dedicated research topic.

Even if the overall positioning accuracy of the cellular communications systems is worse than GNSS under optimum conditions, the high coverage of, e.g., 2G/3G or in the future 3GPP Long Term Evolution (3GPP-LTE) systems can complement GNSS especially in critical situations like urban canyons or indoor. Then, the tight coupled data fusion allows a seamless outdoor and indoor positioning.

So we have identified the following technology gaps to be addressed during the project:

- Tight data fusion of GNSS and communications systems
- Joint NLOS detection and mitigation
- Seamless outdoor-indoor positioning approach

4.3.2 Indoor localization systems

Indoors, where the GNSS based position solution is not available or accurate enough for navigation purposes, i.e., for giving guidance to the user to reach her/his destination, information from several sources need to be fused together. Including self contained sensors, such as accelerometer triads, magnetometers, barometers, and gyros, or a subset of them will be possibly integrated into mass market mobile terminals if their size and power consumption is adequate. The price of MEMS accelerometers is already low enough, allowing them to be included in commercially available mobile terminals, for example, the mobile phone models N95 and N96 by Nokia. The price of magnetometers and barometers is also quite low, whereas MEMS gyros with bias stability sufficiently low to allow navigation are still expensive. In optimistic estimates, prices of good quality MEMS gyros will decrease fast, allowing also gyros to be included into the sensor sets used in mass market mobile terminals for personal indoor navigation. In more conservative scenarios, the personal indoor navigators for mass-market receivers must be implemented without gyros in the near future.

From accuracy point of view, particle filters offer optimal method for fusing together the information from navigation sensors, indoor map matching based on floor plans of the buildings and WLAN positioning. On the other hand, computational load from particle filtering with number of particles sufficient for accurate estimation may be unrealistic for mass-market user terminals, as the heavy

computing also means high power consumption. Therefore the applicability of suboptimal but computationally less demanding algorithms need to be studied.

Gaps:

- Navigation without GNSS signals – seamless outdoor-to-indoor transition
- PDR with uncertain heading due to magnetic field distortions and gyro drift
- Efficient detection of motion mode (static / walking / other)
- Efficient creation of radio map
- Efficient creation of indoor magnetic field map
- Solving the trade-off between accuracy and computational load of position estimation algorithm
 - No filter / EKF / EKF with constraints / hidden Markov model / Particle filtering

4.4 Other

4.4.1 Wireless communications receiver positioning algorithms

Although cellular wireless communication systems provide excellent coverage in urban and most indoor environments, the position accuracy of these systems is limited by self-interference, multipath and NLOS propagation. Close to a serving BS, the signal-to-interference ratio is usually so large that neighbouring BSs cannot be heard by the MS. While this self-interference is desirable for communication purposes, it is undesirable for navigation purposes as we need to detect at least three BSs for positioning. Multipath propagation causes a positive or negative bias in timing based measurements while NLOS propagation always causes a positive bias. However, the biases from different measurements generally do not cancel each other and hence, further degrade the positioning accuracy of cellular wireless communication systems.

Standard communication receivers for novel high-data rate Orthogonal Frequency-Division Multiplexing (OFDM) systems, e.g., 3GPP-LTE, have very low requirements on the time synchronization. This will degrade the position estimates based on TOA or TDOA measurements.

Gaps:

- Efficient multipath, NLOS, and interference mitigation algorithms
- Efficient and accurate time synchronization for OFDM receivers

4.4.2 GNSS receiver simulators

As seen in Section 2.1, IRGAL SW receiver simulators nowadays do not have yet the MBOC/CBOC modulation incorporated. None of them includes the E5 Alternate BOC (AltBOC) -modulated signals either.

Also, none of the available GNSS simulators incorporate the unambiguous acquisition or the multipath mitigation unit for tracking under multipath channels.

Moreover, none of the existing simulators is very friendly for algorithm-related developments (since sources are partially or fully encrypted) and many of them are not even available outside the units which develop them.

To summarize, a Galileo-specific software receiver simulator, including Galileo-specific acquisition and tracking, would be highly beneficial to the GNSS R&D community, since none of the current existing simulators seem to address the Galileo-specific issues.

5. References

- [3GPP020372] 3GPP TSG-RAN 020372, “Software blanking for OTDOA positioning”, http://ftp.3gpp.org/tsg_ran/TSG_RAN/TSGR_16/Docs/PDF/RP-020372.pdf.
- [3GPP25123] 3GPP TS 25.123, “Requirements for Support of Radio Resource Management (TDD)”, March 2002.
- [3GPP25133] 3GPP TS 25.133, “Requirements for Support of Radio Resource Management (FDD)”, March 2002.
- [3GPP25215] 3GPP TS 25.215, “Physical Layer Managements (FDD)”, March 2002.
- [3GPP25225] 3GPP TS 25.225, “Physical Layer Managements (TDD)”, March 2002.
- [3GPP25305] 3GPP TS 25.305, “Stage 2 Functional Specification of UE Positioning”, March 2002.
- [3GPP25331] 3GPP TS 25.331, “Radio Resource Control (RRC) Protocol Specification”, March 2002.
- [ABC+08] Esther Anyaegbua, Gary Brodin, John Cooper, Enrique Aguado and Said Boussakta, “An Integrated Pulsed Interference Mitigation for GNSS Receivers”, *Journal of Navigation* (2008), 61:239-255 Cambridge University Press.
- [ABD07] T.A. Abdelrahim, T.Elesseily, A.S.Abdou and K. K.M.W.Sharaf, “ A 12mW fully integrated Low-IF dual-band GPS Receiver on 0.13-um CMOS”, *IEEE International Symposium on Circuits and Systems*, 2007.
- [AMI97] M. Amin, “Interference mitigation in spread spectrum communication systems using time-frequency distributions,” *IEEE Trans. Signal Process.*, vol. 45, no. 1, pp. 90–101, Jan. 1997.
- [ART07] G. Artaud, L. Ries, J.L. Issler, T. Grelier & al., “CBOC performance using software receiver”, *ESA GNSS Signal* 2007
- [ART08] “The Art of ARTUS”, *Inside GNSS*, Spring 2008
- [BAB+06] Borre, K., D. Akos, D. Bertelsen, P. Rinder, and S. Jensen, *A Software-Defined GPS and Galileo Receiver – A Single Frequency Approach*, Birkhäuser, ISBN: 0-8176-4390-7, 2006.
- [BBC+00] B. C. Barker, J.W. Betz, J. E. Clark, et al., “Overview of the GPS M code signal,” in *CDROM Proceedings of the ION National Meeting; Navigating into the New Millennium*, Anaheim, California, USA, January 2000.
- [BD97] G.Brodin and P. Daly, “ GNSS code and carrier tracking in the presence of multipath”, *International journal of satellite communications*, vol. 15(1), pp. 25-34
- [BEN92] R. Benton, et al, “GaAs MMICs for an integrated GPS front-end”, *Proceedings the IEEE Gallium Arsenide Integrated Circuit (GaAs IC) Symposium*, 1992
- [BER06] R. Berenguer, et al, “ A low Power Low Noise Figure GPS/GALILEO Front-End for Handheld applications in a 0.35um SiGs Process”, *IEE RFIC Symposium* , 2006
- [BET99] J. Betz, “The Offset Carrier Modulation for GPS modernization,” in *Proc. of ION Technical meeting*, (Cambridge, Massachusetts), pp. 639–648, Jun 1999.
- [BHL+09] M. Z. H. Bhuiyan, X. Hu, E.S. Lohan, and M. Renfors, “Multipath mitigation performance of multi-correlator based code tracking algorithms in closed and open loop model”, in *CDROM Proc. of European Wireless conference*, May 2009, Aalborg, Denmark.
- [BLR07] M. Z. H. Bhuiyan, E.S. Lohan, M. Renfors, “Peak Tracking algorithm for Galileo-based positioning in multipath fading channels”, in *Proc. of ICC 2007*, pp. 5927-5932, 2007.[BLR08] M. Z. H. Bhuiyan, E. S. Lohan, and M. Renfors. Code tracking algorithms for mitigating multipath effects in fading channels for satellite based positioning. *EURASIP Journal on Advances in Signal Processing*, DOI: 10.1155/2008/863629, 2008.
- [BNV02] R. Battiti, T. L. Nhat, and A. Villani, “Location-aware computing: a neural network model for determining location in wireless LANs”, *Technical Report DIT-02-0083*, February 2002.
- [BP08] D. Borio and L. LoPresti, “Data and Pilot Combining for Composite GNSS Signal Acquisition”, *International Journal of Navigation and Observation*, vol. 2008, Article ID 738183, 12 pages, doi:10.1155/2008/738183
- [BPR00] P. Bahl and V. N. Padmanabhan, “Radar: An in-building RF-based user location and tracking system”, In *Proc. IEEE INFOCOM 2000 Conference on Computer Communications* (March 2000), vol. 2, IEEE, pp. 775-785.
- [BSL09] Daniele Borio, Nadezda Sokolova, G´erard Lachapelle., “Memory Discriminators for Non-Coherent Integration in GNSS Tracking Loops”, in *CDROM Proc. Of ENC-GNSS*, My 2009, Naples, Italy

- [CA+98] Comp, C.J., Axelrad, P., "Adaptive SNR-based carrier phase multipath mitigation technique," in Aerospace and Electronic Systems, IEEE Transactions, vol.34, no.1, pp.264-276, Jan 1998.
- [CCA09] <http://ccar.colorado.edu/gnss/>. Accessed 11.05.2009.
- [CCB07] M. Ciurana, S. Cugno, and F. Barcel-Arroyo, "WLAN indoor positioning based on TOA with two reference points", In Proc. WPNC'07, 4th Workshop On Positioning, Navigation And Communication 2007 (March 2007), IEEE, pp. 23-28.
- [CCK01] P. Castro, P. Chiu, T. Kremenek, and R. Muntz, "A probabilistic room location service for wireless networked environments", In Proceedings of Ubicomp 2001: Ubiquitous Computing (September 2001), G. D. Abowd, B. Brumitt, and S. A. Shafer, Eds., vol. 2201 of Lecture Notes in Computer Science, Springer Verlag, pp. 18+.
- [CCW+06] F. Chastellain, C. Botteron, G. Waelchli, G. Zamuner, D. Manetti, P.-A. Farine, and P. Brault, "A Galileo E1b,c RF Front-End Optimized for Narrowband Interferers Mitigation", in Proc. of GNSS 19th International Technical Meeting of the Satellite Division, 1069-1075, 2006.
- [CF+06] M. Y. Chuang and K. T. Feng, "Adaptive GPS Acquisition Technique in Weak Signal Environment", VTC Spring, 2006, pp. 2612-2616.
- [CGA02] Coordination Group on Access to Location Information for Emergency Services (CGALIES), "Final Report: Report on Implementation Issues Related to Access to Location Information by Emergency Services (E112) in the European Union", <http://www.telematica.de/cgalies/>, February 2002.
- [CHA05] F. Chastellain, C. Botteron, P.A. Farine, "A low Power RF Front-End Architecture for an L1/L2CS GPS Receiver", 18th Technical Meeting of the Satellite Division, 2005
- [CJ08] C.-L. Chang and J.-C. Juang, "Adaptive logic control approach for fast GNSS acquisition", *Electronics Letters*, vol. 44(13), Jun. 2008
- [CME+07] B. Chibout, C. Macabiau, A.-C. Escher, L. Ries, J.-L. Issler, S. Corrazza, M. Bousquet, "Comparison of Acquisition Techniques for GNSS Signal Processing in Geostationary Orbit", ION-NMT, Jan 2007, San Diego, CA.
- [DFF92] A. J. Van Dierendonck, P. Fenton, and T. Ford, "Theory and performance of narrow correlator spacing in a GPS receiver," *Navigation*, vol. 39, no. 3, pp. 265–283, 1992.
- [DFS+05] J. Diez, A. Fernandez, J. S. Silva, L.Marradi, and V. Gabaglio, "Characterization of the Pseudorange Error Due to Code Doppler Shift in Galileo E5 and L1 Receivers Using the GRANADA Bit-True Simulator," in Proc. of ION GNSS, 2005.
- [DRI07] C. O'Driscoll, M. Petovello, and G. Lachapelle, "PLAN Group's Software-Based Receiver: Current Status, Ongoing Work and Ultra-Tight GNSS/INS Integration PLAN Group's Software-Based Receiver: Current Status, Ongoing Work and Ultra-Tight GNSS/INS Integration", Slides from ION, 2007 (<http://www.ion-alberta.org/meetings>)
- [EHM08] H.J. Ehm, S.M. Winter, and R. Weigel, "Investigation of DC-Offset and Flicker Noise for Combined Single Shot Galileo/GPS Receivers With Homodyne Front-End Architecture", IEEE RWS 2008, pp. 447-450.
- [ESE07] T.Esselly and K.M. Sharaf, "A Crystal-Tolerant Fully Integrated Frequency Synthesizer For GPS Receivers: System Perspective", IEEE Int. conf. on microelectronics,, 2006
- [ETS00] ETSI, "Digital Cellular Communications System (Phase 2+): Location Services (LCS): Functional Description: Stage 2", GSM 03.71, V7.3.0, February 2000.
- [EWW08] H.J. Ehm, S.M. Winter, and R. Weigel, "Investigation of DC-Offset and Flicker Noise for Combined Single Shot Galileo/GPS Receivers With Homodyne Front-End Architecture", IEEE RWS 2008, pp. 447-450.
- [FB00] P. Fishman and J. Betz, "Predicting performance of direct acquisition for the M-code signal," in Proc. of ION NMT, pp. 574–582, 2000.
- [FCC99] Federal Communications Commission, "FCC 99-245: Third Report and Order", <http://www.fcc.gov/911/enhanced/>, October 1999.
- [FDM+04] A. Fernandez, J. Diez, L.Marradi, and Vincent.Gabaglio, "Galileo Receiver performance under GPS interference and multipath with the GRANADA Software Receiver," in Proc. of ION GNSS, Sep 2004.
- [FH08] C. di Flora and M. Hermersdorf, "A practical implementation of indoor location-based services using simple WiFi", *Journal of Location Based Services* 2, 2 (June 2008), 87-111.
- [FJ05] P. C. Fenton, J. Jones, "The Theory and Performance of NovAtel Inc.'s Vision Correlator", Proceedings of the 18th International Technical Meeting of The Satellite Division of the Institute of Navigation, Long Beach, CA, September 2005.
- [Gao07] G.X. Gao, "DME/TACAN Interference and its Mitigation in L5/E5 Bands", Proceedings of the 20th International Technical Meeting of the Satellite Division of the

- Institute of Navigation ION GNSS 2007, September 25 - 28, 2007, Fort Worth, Texas, pp. :1191 – 1200.
- [GAR05] A. Garcia-Rodrigues, "ESA/GJU Workshop Promoting tools and facilities for satellite navigation applications", ESA presentation 2005 (http://esamultimedia.esa.int/images/ESA-GJU_workshop/ESA-GJU_workshop_tools_and_facilities_part_1.pdf, active May 2009)
- [GB07] S. A. Golden and S. S. Bateman, "Sensor measurements for Wi-Fi location with emphasis on time-of-arrival ranging", IEEE Trans. on Mobile Computing 6, 10 (Oct. 2007), 1185-1198.
- [GPS08] GPS World, "2008 GPS World Receiver Survey", Jan 2008, pp. 36-57.
- [GPS09] GPS World, "2009 GPS World Receiver Survey", Jan 2009.
- [GR97] L. Garin and J.M Rousseau, "Enhanced strobe correlator multipath rejection for code and carrier," in Proceedings of the International Technical Meeting of the Institute of Navigation (ION-GPS '97), pp. 559-568, Kansas City, Mo, USA, September 1997.
- [GRA01] GRAMMAR project, Deliverable D1.1, "Market Analysis and Core technology Report"
- [GRA06] G. Gramegna et al, "A 56-mW 23-mm² Single-Chip 180-nm CMOS GPS Receiver With 27.2-mW 4.1-mm² Radio", IEEE Journal of Solid State Circuits, VOL. 41, NO. 3, MARCH 2006
- [GRE+05] Gebre-Egziabher, D., A. Razavi, P. Enge, J. Gautier, S. Pullen, B.S. Pervan and D. Akos (2005) Sensitivity and Performance Analysis of Doppler-Aided GPS Carrier-Tracking Loops, NAVIGATION, 52(2), 49-60.
- [GRE06] GREAT Project deliverable "Definition of System Keyblocks", EHE-06-1009-D-A6,15-02-07.
- [GRE08] GREAT Project Deliverable "Final Report for WP3400", EHE-07-2040-D, February 2008.
- [GUS07] M. Gustavsson et al, "A Low Noise Figure 1.2-V CMOS GPS Receiver Integrated as a Part of a Multimode Receiver", IEEE Journal of Solid State Circuits, July 2007
- [GZV01] L. Garin, M. Zhodzichshsky, V. Veitsel, S.S. Novatisky, and F. Kamgar, "Signal correlation technique for a receiver of a spread spectrum signal including a pseudo-random noise code that reduces errors when a multipath signal is present", US Patent 6,272,189 (Magellan), Aug 2001.
- [GZV01] L. Garin, M. Zhodzichshsky, V. Veitsel, S.S. Novatisky, and F. Kamgar, "Signal correlation technique for a receiver of a spread spectrum signal including a pseudo-random noise code that reduces errors when a multipath signal is present", US Patent 6,272,189 (Magellan), Aug 2001.
- [HAI+05] V. Heiries, J A. Avila-Rodrigues, M. Irsigler, G. W. Hein, E. Rebeyrol, and D. Roviras. Acquisition Performance Analysis of Composite Signals for the L1 OS Optimized Signal. In CDROM Proc. of ION GNSS, 2005.
- [HAW06] Hein G.W., Avila-Rodriguez J.A., Wallner S.: MBOC: The New Optimized Spreading Modulation Recommended for GALILEO L1 OS and GPS L1C, Inside GNSS - Working Papers, Vol. 1, No. 4, May/June 2006, pp. 57-65
- [HDR+07] G. Heinrichs, M. Restle, C. Dreischer, and T. Pany. NavX - NSR - A Novel Galileo/GPS Navigation Software Receiver. Proceedings of the 20th International Technical Meeting of the Satellite Division of the Institute of Navigation ION GNSS 2007, September 25 - 28, 2007, Fort Worth Convention Center, Fort Worth, Texas
- [Her06] M. Hermersdorf, "Indoor positioning with a WLAN access point list on a mobile device", In Proc. WSW'2006 at SenSys'2006 (October 2006).
- [HGa08] Heckler, G.W. and Garrison, J.L. Methods for Improving Computational Efficiency in a Global Positioning Satellite Receiver. U.S. Patent application publication. US 2008/0143598 A1. Jun. 19, 2008.
- [HLH+08] H. Hurskainen, E. S. Lohan, X. Hu, J. Raasakka, and J. Nurmi. "Multiple Gate Delay tracking structures for GNSS signals and their evaluation with Simulink, SystemC and VHDL". International Journal of Navigation and Observation, vol. 2008, Article ID 785695, 17 pages, 2008. doi:10.1155/2008/785695.
- [HLR03] R. Hamila, E.S. Lohan, and M. Renfors, "Subchip multipath delay estimation for downlink WCDMA system based on Teager-Kaiser operator", IEEE Communications Letters, Volume: 7 Issue: 1, pp. 1-3, Jan. 2003.
- [Hon] <http://www.magneticsensors.com/products.html#DRM>
- [HOR+04] V. Heiries, D. Oviras, L. Ries, and V. Calmettes, "Analysis of non ambiguous BOC signal Acquisition performance," in CDROM Proc. of ION GNSS, (Long Beach, CA), Sep 2004.

- [ICB+06] F. Izquierdo, M. Ciurana, F. Barcelo, J. Paradells, and E. Zola, "Performance evaluation of a TOA-based trilateration method to locate terminals in WLAN" In Proc. of 1st International Symposium on Wireless Pervasive Computing, 2006 (Jan. 2006), IEEE, pp. 1-6.
- [IE03] M. Irsigler and B. Eissfeller, "Comparison of multipath mitigation techniques with consideration of future signal structures," in Proceedings of the International Technical Meeting of the Institute of Navigation (ION-GPS/GNSS '03), pp. 2584-2592, Portland, Ore, USA, September 2003.
- [IRG08] IRGAL Final Workshop, <http://www.irgal.com/>, Sep 2008
- [JOO07] I. Joo, J.E. Lee, S. Lee, J.H. Kim, D.W. Lim, S.J. Lee, "S/W based IF Signal Simulator Prototyping for L1 C/A, L2C, and E1(B&C)", IEEE ICICS 2007.
- [KAD04] T. Kadoyama, et al., "A Complete Single-Chip GPS Receiver With 1.6-V 24-mW Radio in 0.18-um CMOS", IEEE Journal of Solid State Circuits, VOL. 39, NO. 4, APRIL 2004
- [KAL03] J. Kammann, M. Angermann, and B. Lami, "A New Mobility Model Based On Maps", Proceedings of the IEEE Vehicular Technology Conference (VTC) Fall, October 2003.
- [Kay93] S. M. Kay, "Fundamentals of Statistical Signal Processing, Volume 1: Estimation Theory", Prentice Hall Signal Processing Series, 1993.
- [KDH+06] A. Konovaltsev, H. Denks, A. Hornbostel, M. Soellner, M. Witzke, "General Approach to Analysis of GNSS Signal Acquisition Performance with Application to GALILEO Signals", NAVITEC; 2006, Noordwijk, Netherlands
- [KH06] E.D. Kaplan and C. Hegarty, "Understanding GPS: Principles and applications", Artech House, 2006.
- [KH06b] K. W. Kolodziej and J. Hjelm, "Local Positioning Systems: LBS Applications and Services", Taylor&Francis, 2006.
- [KKR+08] M. Khider, S. Kaiser, P. Robertson, and M. Angermann, "A Novel Movement Model for Pedestrians Suitable for Personal Navigation" Proceedings of the ION NTM, January 2008.
- [KL03] B.J. Kang and I.K. Lee, "A performance comparison of code acquisition techniques in DS-CDMA system", Wireless Personal Communications, vol. 25, 2003, pp. 163-176.
- [KO05] Jinho Ko, Jongmoon Kim, Sanghyun Cho, and Kwyro Lee, "A 19-mW 2.6-mm2 L1/L2 Dual-Band CMOS GPS Receiver", IEEE Journal of Solid State Circuits, Vol 40, N° 7, July 2005
- [LAT07] A. de Latour, T. Grelier, G. Artaud, L. Ries, and J.L. Issler, "Subcarrier Tracking Performances of BOC, ALTBOC and MBOC Signals", CDROM Proc. Of ION-GNSS 2007, Fort Worth, Texas.
- [LBR04] E. S. Lohan, A. Burian, and M. Renfors, "Acquisition of Galileo signals in hybrid double-dwell approaches", in CDROM Proceedings of ESA NAVITEC, Dec 2004.
- [LBR08] E.S. Lohan, A. Burian, and M. Renfors "Low-complexity acquisition methods for split-spectrum CDMA signals", Wiley International Journal of Satellite Communications, vol. 26, pp. 503-52, 2008
- [LCB98] Landry, R.J. Calmettes, V. Bousquet, M. "Impact of interference on a generic GPS receiver and assessment of mitigation techniques", 1998 IEEE 5th International Symposium on Spread Spectrum Techniques and Applications Proceedings, Sep 1998, vol. 1, pp. 87-91.
- [Leh02] A. Lehtinen, "Doppler positioning with GPS" M.Sc. thesis, Tampere University of Technology, 2002. url: <http://math.tut.fi/posgroup/DopplerPositioningwithGPS.pdf>
- [LFW06] D. Lu, Q. Feng, and R. Wu, "Survey on Interference Mitigation via Adaptive Array Processing in GPS", Progress In Electromagnetics Research Symposium 2006, Cambridge, USA, March 26-29.
- [LLR04] A. Lakhzouri, E. S. Lohan, and M. Renfors, "Reduced-Complexity Time-Domain Correlation for Acquisition and Tracking of BOC-Modulated Signals", in CDROM Proceedings of ESA NAVITEC, Dec 2004.
- [LLR05] E. S. Lohan, A. Lakhzouri, and M. Renfors, "Selection of the multiple-dwell hybrid-search strategy for the acquisition of Galileo signals in fading channels", in CDROM Proc. of IEEE PIMRC, Sep 2004.
- [LLR06] E. S. Lohan, A. Lakhzouri, and M. Renfors, "Feedforward delay estimators in adverse multipath propagation for Galileo and modernized GPS signals", EURASIP Journal of Applied Signal Processing, vol 2006, Article ID 50971, 19 pages
- [LML08] R.J. R. Landry, P. Mouyon, D. Lekaim, "Interference mitigation in spread spectrum systems by wavelet coefficients thresholding", European Transactions on Telecommunications, vol. 9(2), pp. 191 - 202, published online: 12 Sep 2008.

- [LR07] E.S. Lohan and M. Renfors, "Correlation properties of Multiplexed Binary Offset Carrier (MBOC) modulation", European Wireless Conference, Apr 2007.
- [LTE-080995] "3GPP-LTE, RP-080995: Working Item Proposal for Positioning Support for LTE", Qualcomm Europe, 3GPP TSG RAN#42, December 2008.
- [LTE-090353] R1-090353, "On OTDOA in LTE", Qualcomm, 3GPP TSG-RAN WG1 #55bis, Ljubljana, Slovenia, January 2009.
- [LTE-090765] R1-090765, "LTE neighbor cell hearability", Nortel, 3GPP TSG-RAN1 #56, Athens, Greece, February 2009.
- [LTE-090918] R1-090918, "On OTDOA method for LTE positioning", Ericsson, 3GPP TSG-RAN1 #56, Athens, Greece, February 2009.
- [Mag] <http://pro.magellangps.com/>
- [MAO08] W.L. Mao, "Narrowband Interference Rejection in GPS receiver using Adaptive Lattice Predictor, WSEAS Transactions on Systems, Feb 2008, vol. 7(2).
- [MAT05] P. G. Mattos, "Acquisition of the Galileo OS L1b/c signal for the mass-market receiver," in Proceedings of the 18th International Technical Meeting of the Satellite Division of the Institute of Navigation (ION GNSS '05), pp. 1143–1152, Long Beach, California, USA, September 2005.
- [MB99] G. A. McGraw and M. Braasch, "GNSS multipath mitigation using high resolution correlator concepts," in Proceedings of the National Technical Meeting of the Institute of Navigation (ION-NTM '99), pp. 333–342, San Diego, California, USA, January 1999.
- [MCG05] O. Mezentsev, J. Collin and G. Lachapelle (2005) "Pedestrian Dead Reckoning - A Solution to Navigation in GPS Signal Degraded Areas," Geomatica, Volume 59, #2, pp. 175-182.
- [MLG+03] N. Martin, V. Leblond, G. Guillotel, and V. Heiries, "BOC(x,y) signal acquisition techniques and performances," in Proc. of ION-GPS2003, (Portland, OR, US), pp. 188–198, Sep 2003.
- [MON03] G. Montagne et al, "A 35-mW 3.6-mm² Fully Integrated 0.18-um CMOS GPS Radio", IEEE Journal of Solid State Circuits VOL. 38, NO. 7, JULY 2003,
- [MPL08] F. Macchi, M.G. Petovello and G. Lachapelle, "Consequences of MBOC approximation by BOC modulation", ION-GNSS 2008, Savannah, GA
- [MSD94] M. Medley, G. Saulnier, and P. Das, "Applications of the wavelet transform in spread spectrum communications systems," in Proc. SPIE, Wavelet Applicat., Orlando, FL, Apr. 1994, pp. 54–68.
- [MSM08] B. Motella, S. Savasta, D. Margaria, F. Dovis, An Interference Impact Assessment Model for GNSS Signals, ION GNSS 2008, Savannah, Georgia (USA), September 16-19, 2008.
- [NAMU06] P. Mimford, "The NAMURU Open GNSS Receiver Platform" 19th Int. Tech. Meeting of the Satellite Division of the U.S. Inst. of Navigation, Fort Worth, Texas, USA, 2006
- [NAV09] https://www.navtechgps.com/Shop/equipment/software_receivers/index.asp. Accessed 11.05.2009.
- [NEM07] "Multiband GNSS Receiver", Nemerix, US Patent N° US2007/0096980A1, Pub. Date May 3, 2007
- [NSL05] F. D. Nunes, F. M. G. Sousa, and J. M. N. Leitao, "Parallel Bayesian Code Delay and Doppler Frequency Estimation in GNSS Receivers ", Proceedings of the 18th International Technical Meeting of The Satellite Division of the Institute of Navigation, Long Beach, CA, September 2005.
- [PAN06] T. Pany, D. Sanroma, J. Avila-Rodriguez, B. Eissfeller, F. Forster, "High precision signal processing in a PC software receiver", IEEE Aerospace and Electronic Systems Magazine, vol. 21(8), pp. 20-25, Aug. 2006.
- [PDL08] M.G. Petovello, C. O'Driscoll and G. Lachapelle, "Carrier Phase Tracking of Weak Signals Using Different Receiver Architectures", ION NMT 2008, San Diego, CA, Jan 2008.
- [PIE02] Pany, T., Irsigler, M., Eissfeller, B., Winkel, J. Code and Carrier Phase Tracking Performance of a Future Galileo RTK Receiver, Proceedings of the European Navigation Conference ENC-GNSS 2002, Copenhagen, 27-30 May 2002
- [PKC02] P. Prasithsangaree, P. Krishnamurthy, and P. Chrysanthis, "On indoor position location with wireless LANs", In Proc. 13th IEEE International Symposium on Personal Indoor and Mobile Radio Communications. (PIMRC2002) (September 2002), vol. 2, IEEE, pp. 720-724.

- [PL06] Petovello, M.G. and G. Lachapelle (2006) Comparison of Vector-Based Software Receiver Implementations with Application to Ultra-Tight GPS/INS Integration, ION GNSS 2006, Fort Worth, TX, Institute of Navigation, 1790-1799.
- [PLR05] E. Pajala, E. S. Lohan, and M. Renfors, "CFAR detectors for hybrid-search acquisition of Galileo signals", in CDROM Proc. of ENC-GNSS, Munich, Jul 2005
- [PSI01] M. Psiaki, "Block Acquisition of weak GPS signals in a software receiver", ION GPS 2001
- [PSI01b] Psiaki, M.L. (2001) Smoother-Based GPS Signal Tracking in a Software Receiver, ION GPS 2001, Salt Lake City, UT, Institute of Navigation, 2900-2913.
- [QUA09] Qualcomm gpsone, <http://www.qctconnect.com/products/gpsone.html>, 2009.
- [R30] <http://www.navtechgps.com/pdf/r30.pdf>
- [RHP+09] J. Raasakka, H. Hurskainen, T. Paakki, J. Nurmi. Modeling Multi-Core Software GNSS Receiver with Real Time SW Receiver. To Appear in Proceeding of ION GNSS 2009, Sep 2009, Savannah, Georgia.
- [RHS+03] Rohmer G, Heinrichs G, Seybold J, Haas S, Leleux A (2003) "Integrated GNSS and Mobile Communication Terminal (NAVCOM)" ENC-GNSS2003 - The European Navigation Conference, Graz, Austria, April 2003.
- [RMT02] T. Roos, P. Myllymaki, H. Tirri, P. Misikangas, and J. Sievanen, "A probabilistic approach to WLAN user location estimation", International Journal of Wireless Information Networks 9, 3 (July 2002), 155-164.
- [RP94] L. A. Rusch, and H. V. Poor, "Narrowband interference suppression in CDMA spread spectrum communications", IEEE Trans. Commun. , 1994, 42, pp. 1969-1979.
- [SAHU05] D.Sahu, et al, "A 90nm CMOS Single-Chip GPS Receiver with 5dBm Out-of-Band IIP3 2.0dB NF", IEEE International Solid State Circuits
- [SAM09] M. F. Samad, "Effects of MBOC Modulation on GNSS Acquisition Stage", May 2009, MSc thesis at Tampere University of Technology
- [SHA06] Shanmugam, S.K., et. al, "Pre-correlation noise and interference suppression for use in direct-sequence spread spectrum systems with periodic PRN codes", Proceedings of the GNSS 2006 Conference, Institute of Navigation, Fort Worth, TX, September 26-29, 2006.
- [SHA07] S.K. Shanmugam, "Narrowband Interference Suppression Performance of Multi-Correlation Differential Detection", Proc. of ENC-GNSS 2007 (Session B5), Geneva, Switzerland, May 29-31, 2007
- [SIS-ICD08] ESA/GSA, Galileo Signal in Space Interface Control Documentation (*OS SIS ICD*), Draft 1, Feb 2008
- [SJK+08] S. Söderholm, T. Jokitalo, K. Kaisti, H. Kuusniemi, and H. Naukkarinen. Smart Positioning with Fastrax's Software Receiver Solution. In Proc. ION GNSS 2008, Sep. 16 – 19, 2008. Savannah, Georgia, US.
- [SK02] A. Smailagic, and D. Kogan, "Location sensing and privacy in a context-aware computing environment", IEEE Wireless Communications 9, 5 (October 2002), 10-17.
- [SK08] J. Syrjärinne, J. Käppi, "Method and apparatus for lowering power use by a ranging receiver" US Patent 7,409,188 (Nokia), Aug 2008.
- [SKY09] Skyhook Wireless, <http://www.skyhookwireless.com>, 2009.
- [SL+07] D. Skournetou and E. S. Lohan, "Indoor location awareness based on the non-coherent correlation function for GNSS signals", in Proc. of Finnish Signal Processing Symposium (FINSIG'07), 6 p, Oulu, Finland, 2007.
- [SL+08] D. Skournetou and E. S. Lohan, "Discontinuity-based code delay estimator for GNSS signals", in Proc. of 4th Advanced Satellite Mobile Systems (ASMS) conference, pp. 213-222, Bologna, Italy, 2008.
- [SL09] M.F. Samad and E.S. Lohan, "MBOC Performance in Unambiguous Acquisition", in Proc. of ENC-GNSS2009, May 2009, Naples, Italy.
- [SLE01] J.-M. Sleewaegen, "Method and apparatus for processing signals for ranging applications", European Patent Application EP 1,288,672 A1, Septentrio, Aug 2001.
- [SN04] A. Schmid and A. Neubauer. Performance evaluation of differential correlation for single shot measurement positioning. In CDROM Proc. of ION-GNSS, 2004.
- [SP93] N. R. Shanbhag and K. K. Parhi: "Relaxed look-ahead pipelined LMS adaptive filters and their application to ADPCM coder", IEEE Trans. Circuits and System Part-II, vol. 40, pp. 753-766, Dec. 1993.
- [SR09] William Storms and John Raquet, "Magnetic Field Aided Indoor Navigation", to Appear in Proc. ENC-GNSS 2009, May 2009, Naples, Italy.

- [SSL+09] D. Skournetou, A. H. Sayed and E. S. Lohan, "A deconvolution algorithm for estimating jointly the Line-Of-Sight code delay and carrier phase of GNSS signals", in European GNSS, Naples, Italy, 2009 (in press).
- [SSN+03] A. Simsky, J.-M. Sleewaegen, P. Nemry, and J.V. Hees, "Signal performance and measurement noise assessment of the first L2C signal-in-space", Position, Location, And Navigation Symposium, 2006 IEEE/ION, April 25-27, 2006, pp. 834- 839
- [SST+08] T. Strang, F. Schubert, S. Thöler, R. Oberweis et al., „Lokalisierungsverfahren“, Shaker Verlag GmbH, ISBN 978-3-8322-7492-4, 2008
- [VDT08] V.D.Torre,M.Conta,R.Chokkalingam,G.Cusmai,P.Rossi,F.Svelto."A 20mW 3.24mm² Fully Integrated GPS Radio for Location Based Services".
- [VSA+04] M. Vaezi, S. M. Safavi and H. Aghaeinia, "Fast GPS Signal Acquisition Employing Adaptive Threshold", Proceedings of 2nd ESA Workshop on Satellite Navigation User Equipment Technologies (NAVITEC '2004, December 8-10), Noordwijk, The Netherlands, 2004.
- [VTI09] CMA3000 3-axis accelerometer specification datasheet. url: http://www.vti.fi/en/products/accelerometers/consumer_electronics/cma3000_series/
- [VZZ98] V.A. Veitsel, A.V. Zhdanov, and M. I. Zhodzishsky, "The Mitigation of Multipath Errors by Strobe Correlators in GPS/GLONASS Receivers", GPS Solutions, vol. 2(2), pp. 38-45, Oct.1998.
- [WAR98] Ward, P., "Performance Comparisons Between FLL, PLL and a Novel FLL-Assisted-PLL Carrier Tracking Loop Under RF Interference Conditions," Proceedings of the 11th International Technical Meeting of The Satellite Division of The Institute of Navigation, Nashville, TN, September 1998, pp. 783–795.
- [WHE43] ICT-217033 WHERE, "Deliverable 4.3: Modelling of the Channel and its variability", December 2008.
- [WIN09] WINNER Project, <http://www.ist-winner.org>, 2009.
- [WIN481] WINNER II, "D4.8.1: Intramode and Intermodulation Cooperation Schemes Definition", Deliverable, IST-4-027756, June 2006.
- [WIN482] WINNER II, "D4.8.2: Cooperation Schemes Validation", Deliverable, IST-4-027756, June 2007.
- [WMY08] S. Wang, J.Min, and B. K. Yi, "Location Based Services for Mobiles: Technologies and Standards", Tutorial at the IEEE International Conference on Communications (ICC) May 2008.
- [WOO01] R.K. Woo, "Global positioning system receiver with improved multipath signal rejection", US Patent 6,259,401, Navcom Technologies, Jul 2001.
- [WPU+08] R. Weiler, P. Blunt, M. Unwin, and S. Hodgart, "A Direct-Conversion Receiver for Wide-Band GNSS Signals", GNSS Signals & Signal Processing Workshop, Toulouse, France. Apr 2008.
- [WW04] M. Wallbaum, and T. Wasch, "Markov localization of wireless local area network clients", In Proc. Wireless On-Demand Network Systems. First IFIP TC6 Working Conference, WONS2004 (2004), R. Battiti, M. Conti, and R. Cigno, Eds., vol. 2928 of Lecture Notes in Computer Science, Springer Verlag, pp. 1-15.
- [XU07] "A Low-IF CMOS Simultaneous GPS Receiver Integrated in a Multimode Transceiver", IEEE Custom Integrated Circuit Conference, 2007
- [YAS03] M. Youssef, A. Agrawala, and A. U. Shankar, "WLAN location determination via clustering and probability distributions", In Proc. the First IEEE International Conference on Pervasive Computing and Communications (PerCom 2003) (March 2003), IEEE Computer Society, pp. 143-150.
- [YHT04] C. Yang, C. Hegarty, and M. Tran, "Acquisition of the GPS L5 signal using coherent combining of I5 and Q5," in Proceedings of the 17th International Technical Meeting of the Satellite Division of the Institute of Navigation (*ION GNSS '04*), pp. 2184–2195, Long Beach, California, USA, September 2004.
- [Zha00] Y. Zhao, "Mobile Phone Location Determination and Its Impact on Intelligent Transportation Systems", IEEE Transactions on Intelligent Transportation Systems, Vol. 1, No. 1, March 2000.
- [Zha02] Y. Zhao, "Standardization of Mobile Phone Positioning for 3G Systems", IEEE Communications Magazine, July 2002.
- [ZVA02] M. I. Zhodzishsky, V.A. Veitsel, and J. Ashjaee, "Method and apparatus for reducing multipath errors in demodulation of pseudo-random coded signals", US Patent 6,493,378 (TopCon), Dec. 2002.