



ADMAP-GAS

*„Unconventional (Advanced)
Manufacturing Processes for Gas-
Engine Turbine Components“*

ADMAP-GAS – Unconventional (Advanced) Manufacturing Processes for Gas-Engine Turbine Components

Aerodays 2011 – Innovation for Sustainable Aviation in a
Global Environment

Thursday, 31st March 2011

Dipl.-Ing. Dražen Veselovac

WZL, RWTH Aachen University, Germany

Outline

- 1 Project Description ADMAP-GAS**
- 2 Actual Situation in Fir Tree Production and Challenges for the Future**
- 3 Research and Developments on W-EDM and AWJM**
- 4 Summary and Outlook**

Objectives of ADMAP-GAS

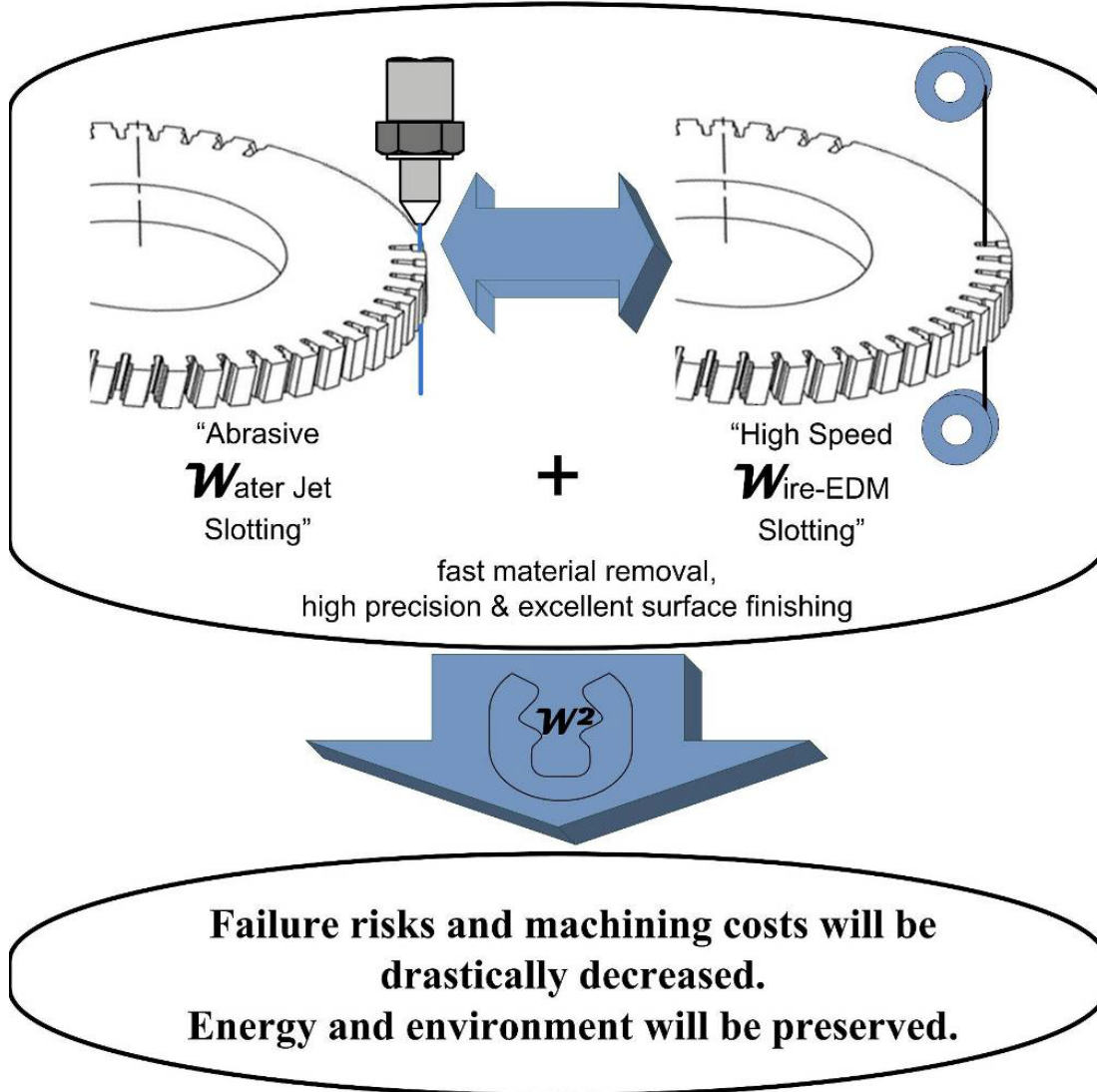

- Substitute critical broaching process of fir tree structures in gas turbine disks by „Abrasive Water Jet Slotting“ and „High Speed Wire Electro Discharge Slotting“.

Impact on Turbine Industry after ADMAP-GAS

Fir tree



ADMAP-GAS processes

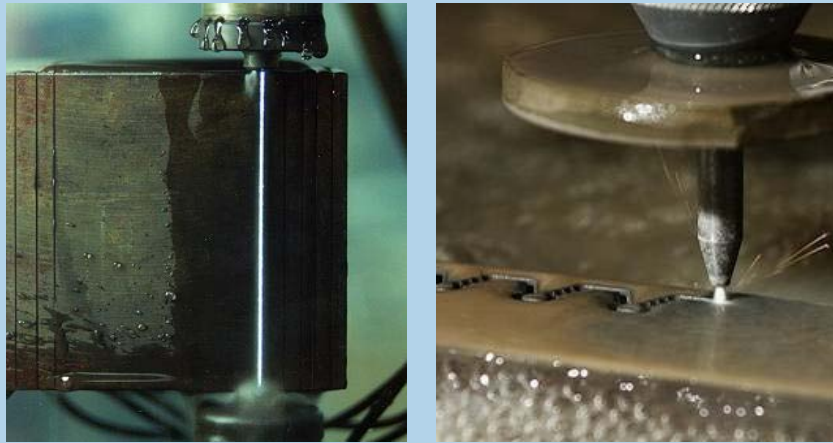

- Today's challenges in fir tree production:
 - High investment costs for machine tools
 - High tool costs
 - Very inflexible
 - Large physical footprint
- Improvements through ADMAP-GAS:
 - Low tool manufacturing costs
 - Low maintenance costs because of low tool wear
 - Continuous production process
 - Flexible and fast change in production line when workpiece geometry has to be changed.
 - Requirement of less machining space
 - Easy correcting of process inaccuracies during the process.

Workpackage Organisation and Interaction

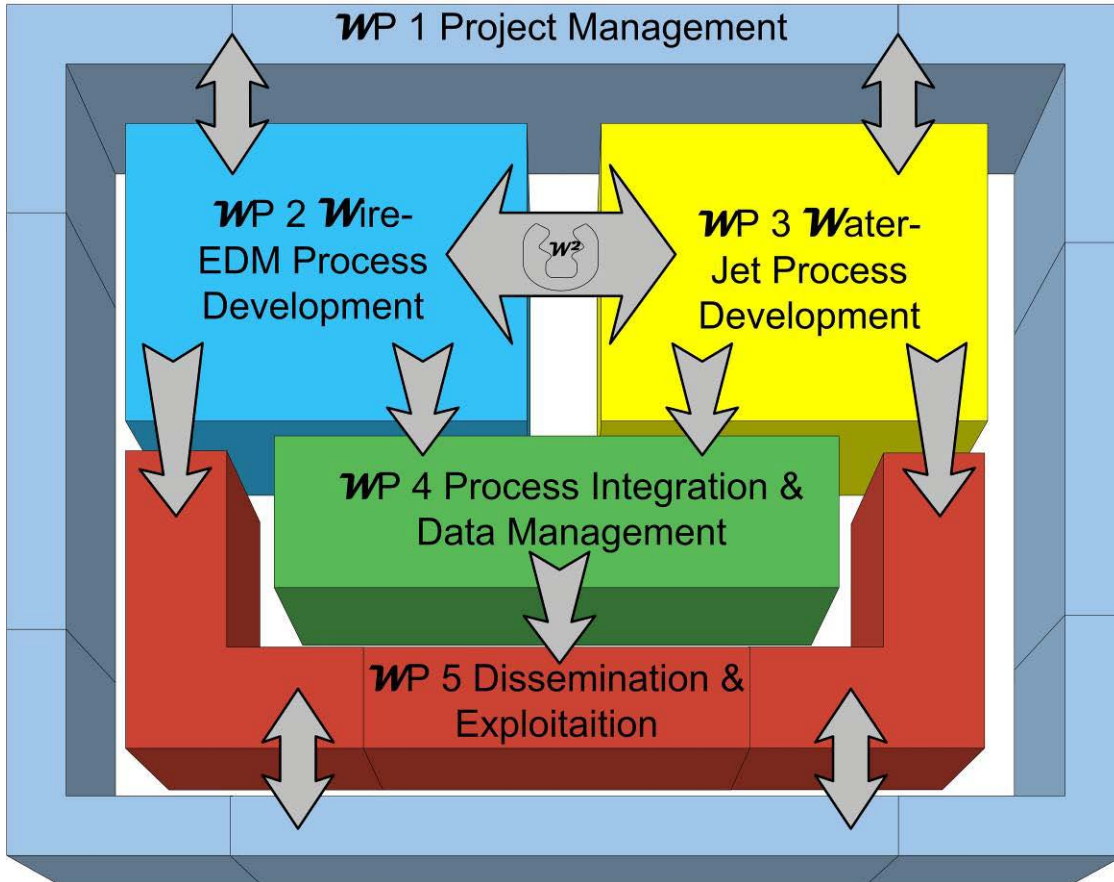

- Five work packages including:
 - Management
 - Research and developments in Wire-EDM and AWJM
 - Process integration and data management
 - Dissemination and exploitation
- Holistic build up
- Interaction between work packages

Project Details and Consortium

Funded by EU



ADMAP-GAS consortium

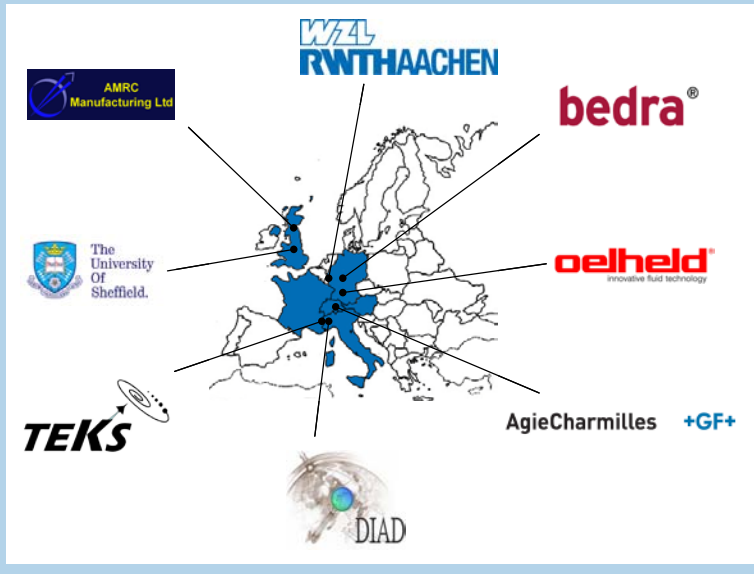

■ Project details:

- Collaborative project within the Seventh Framework Programme of the European Commission
- Addresses call for theme: Transport (including Aeronautics)
- Total budget: 4.3 m €; EC contribution: 2.9 m €
- Duration: 36 months
- Start date: 01/08/2009

■ Consortium:

- Eight partners from five European countries
- Two world leading industrial partners
- Three SMEs
- One research institution
- Two outstanding higher education partners
- No turbine manufacturer for independency

Outline

- 1 Project Description ADMAP-GAS
- 2 Actual Situation in Fir Tree Production and Challenges for the Future
- 3 Research and Developments on W-EDM and AWJM
- 4 Summary and Outlook

Characteristics and Manufacturing of Fir Tree Slots

Fir tree geometries

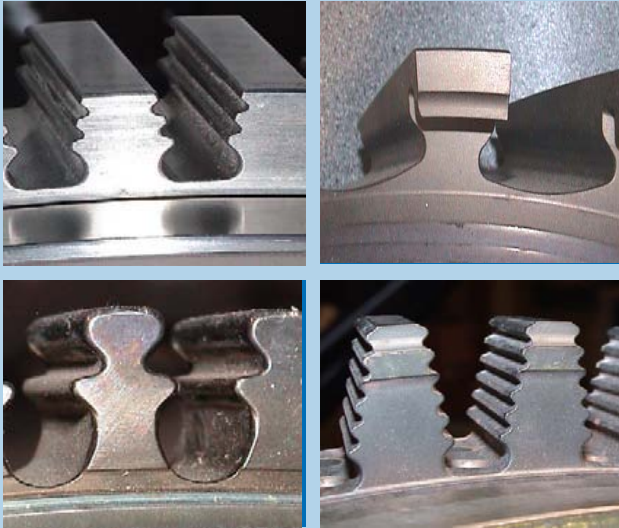

Broaching machine



■ Characteristics of fir trees:

- Different geometries for form fit between disc and blade.
- Small profile tolerances.
- High requirements on surface integrity because of safety critical components.

■ Manufacturing of fir trees:

- Broaching process is used for fir tree production.
- Roughing and finishing within one stroke.
- Typically two broaching machines with the same geometry in parallel are needed to handle the production frequency.
- High requirements on surface integrity are met.
- High repeatability
- High productivity
- Through re-shaping and re-coating 800 - 1000 fir trees can be produced with one tool.
- Good process reliability and repeatability.

Disadvantages and Problems of Broaching Fir Tree Slots

■ Machine:

- High buying costs up to 3 m € for one broaching machine.
- Large footprint
- High energy consumption because of high cutting forces.

■ Tool:

- Specific tool for each fir tree geometry
- High buying costs: average 15 k €
- Long lead time from drawing until insertion into production process
- Long time for set-up and change of tool
- Need cutting lubricant

■ General:

- Broaching process is bottle neck in process chain
- Batches minor five parts are not profitable.

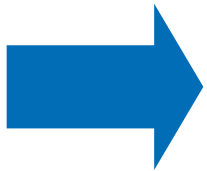

Need of alternative manufacturing processes for substitution of broaching process for fir tree manufacturing.

Researches on Alternatives to Broaching Process

Creep feed grinding



Solid carbide profiled milling



- Researches have been carried out on grinding and milling of fir tree slots.
- Full or partial fir tree shapes of tools
- First results show:
 - Machining precision and quality lower than broaching
 - Tool costs/piece: 10 times higher than broaching
- High potential for unconventional machining technologies for fir tree slotting due to economic aspects and flexibility.

Outline

- 1 Project Description ADMAP-GAS
- 2 Actual Situation in Fir Tree Production and Challenges for the Future
- 3 Research and Developments on W-EDM and AWJM
- 4 Summary and Outlook

Research Material: Inconel 718

Application area of Inconel 718

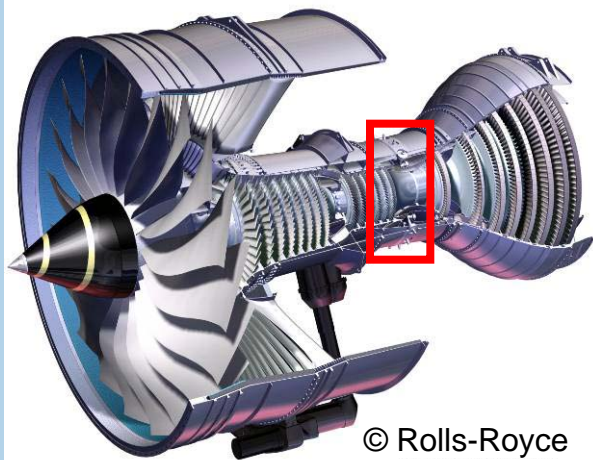

Disk



- Inconel 718 is a typical material used for aero engine components
- Representative component: High Pressure Compressor Disk
- Key properties of Inconel 718:
 - Temperature creep resistance
 - Fatigue life
 - Phase stability
 - Oxidation and corrosion resistance
- Poor machinability of Inconel 718.

Requirements for ADMAP-GAS Processes

Test/ reference geometry

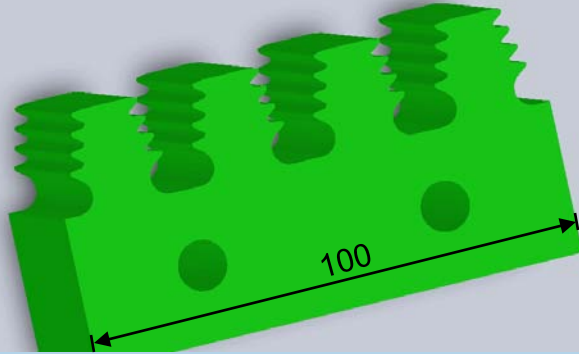

Drawing of geometry

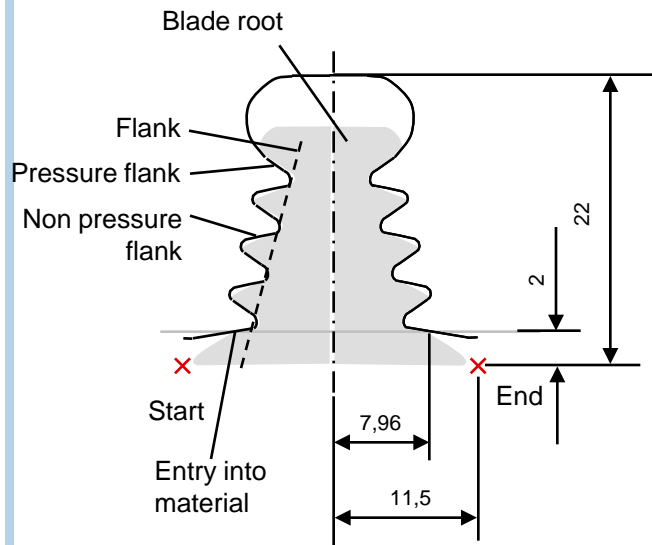

- Given requirements which have to be met by ADMAP-GAS processes:
 - Surface quality capability: R_a 0.8 μm
 - Geometrical quality capability: profile tolerance 5 μm
 - Slot length capability $\geq 40\text{mm}$
 - Highly flexible production
 - Highly automated production (reduced need of human garrison)
 - High process reliability and repeatability: geometry, quality, residual stresses, etc.
 - Automated real time process quality monitoring
 - Lower energy consumption and environmental impact (consumables, emissions, etc.) in respect of broaching.
- Test/ reference geometry for researches:
 - Form tolerance among flanks 0.005 mm
 - Form tolerance among non pressure flanks 0.0100 mm
 - Form tolerance among pressure flanks 0.005 mm
 - Minimal inner radius 0.3 mm

Introduction to High Speed Wire-EDM Slotting

Wire-EDM machine



Wire-EDM process

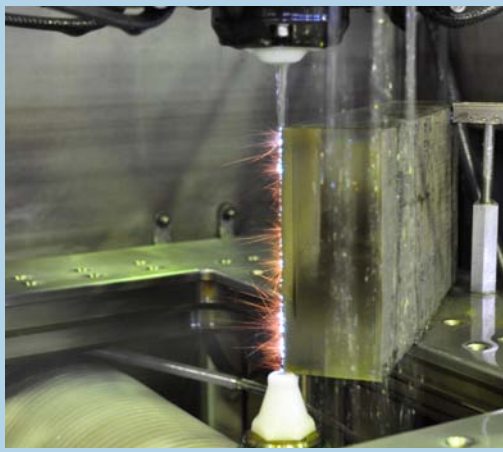

Initial situation to substitute broaching:

- Low investment costs
- Low consumables and energy costs
- High flexibility
- Reduced surface roughness values through trim cuts
- Very good reliability and repeatability

Challenge for Wire-EDM to substitute broaching:

- Increase of cutting rate for high productivity
- Fulfil requirements on surface integrity and part tolerances:
 - Minimise heat affected zone
 - No contamination into parent material
- Increase accuracy for bad process/ flushing conditions
- Develop monitoring system to control process stability

Meet the Challenge through Generator Developments

Geometrical check

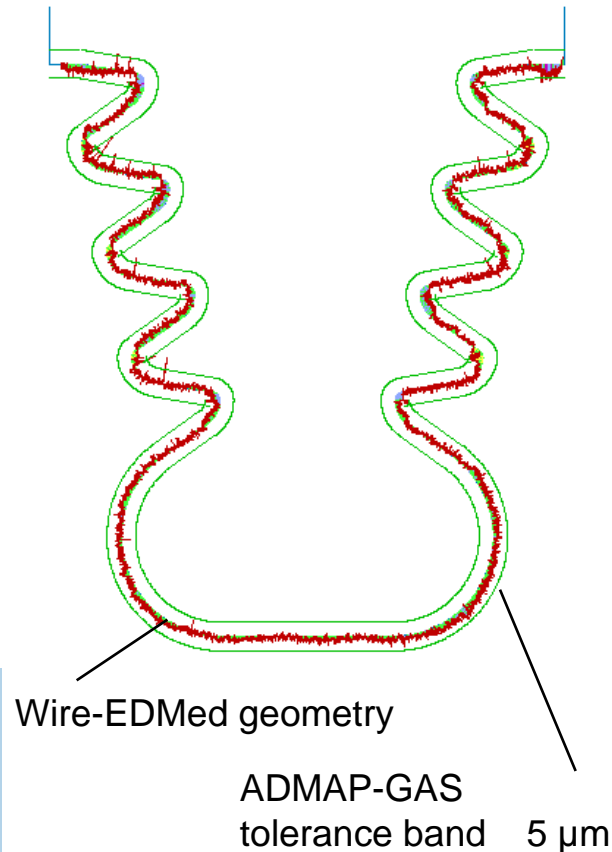

- Special ADMAP-GAS Wire-EDM technology was developed for cutting Inconel 718.
- Project requirements are met after three cuts. (rough cut, 1st trim cut, 2nd trim cut)
- Tight tolerances in process quality for repeatability and reliability:
 - Cutting rate
 - Surface roughness
 - Geometrical aspects
- Cutting time (overall three cuts) for one fir tree \approx 1 h.

Meet the Challenge through Wire Developments

Coated wire

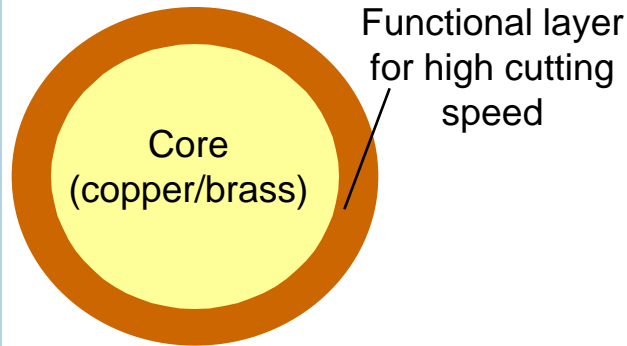

Coated wire with Ni-layer

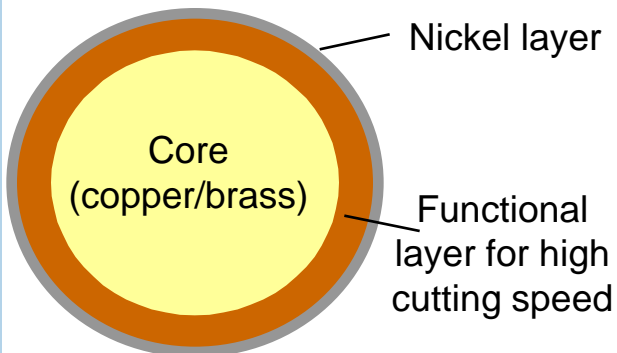

- Similar process behavior for steel and Inconel 718. Even more productivity with coated wires in Inconel 718.
- Best productivity with coated wire: removal rate $V_w = 243 \text{ mm}^2/\text{min}$
- Decreasing contamination by nickel layered wire.
- Result data:
 - Contamination thickness layer: minor 50 nm
 - Copper and Zink in rim zone
- Finished surface met projects requirements.

Meet the Challenge through Dielectric and Additive Developments

Application for additive moistening

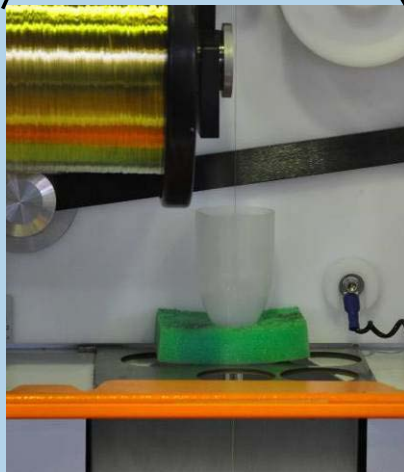

- Application for additive moistening to increase cutting rates:
 - Emulsified composition of chemical elements.
 - Additive film directly on wire for increasing material removal rate.
- First results show an increase of material removal rates up to 20 %.
- Developments in CH-based dielectrics for Wire-EDM.
- Advantage: No corrosion on manufactured part.
- Additives with lower viscosity show best process results.

Introduction to Abrasive Water Jet Slotting

AWJM machine



AWJM process



Initial situation to substitute broaching:

- Low investment costs
- Low consumables and energy costs
- High flexibility
- High cutting rates

Challenge for AWJM to substitute broaching:

- Enhance surface roughness values
- Fulfil requirements on surface integrity and part tolerances:
 - Minimise tapering
 - Decrease of inserting of abrasive material in surface
- Improve nozzle life
- Develop monitoring system to control process stability.

Meet the Challenge through Machine Tool Developments

Test set-up

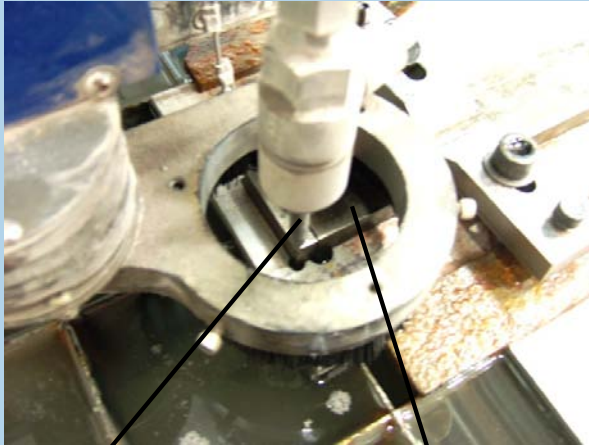

Water jet
head

Test material
Inconel 718

Close-up of cutting tests



- Experiments to characterise pre-programmed parameters on Inconel 718 with respect to surface quality and geometrical tolerances have been carried out.
- Working pressure at a range up to 60000 psi (4140 bar) with a 0.35 mm nozzle
- Surfaces were generated with 5 quality settings
- Measured cutting speeds:
 - XROUGH 3861 mm²/min
 - ROUGH 2119 mm²/min
 - MEDIUM 1456 mm²/min
 - FINE 1092 mm²/min
 - XFINE 897 mm²/min

Surface Integrity Measurements of AWJMed Surfaces

Measuring directions

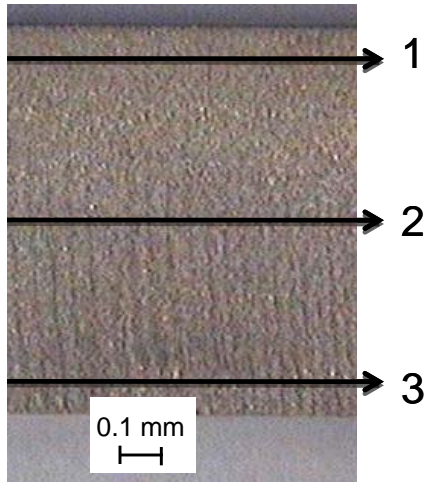

Surface close-up

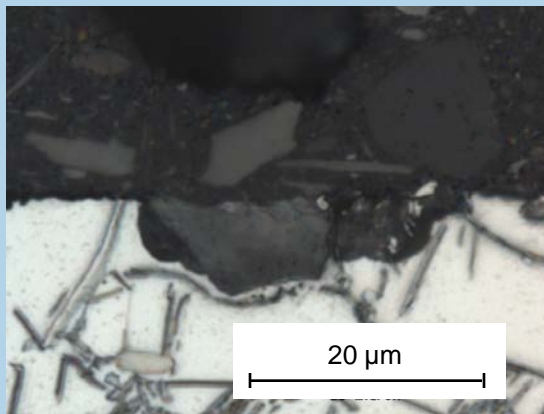

- The surfaces produced by an AWJ have two distinctly different zones:
 - Smooth and
 - Striation zone.
- The upper zone is characterised by surface roughness whereas the lower zone by waviness. The striation zone may be caused by:
 - Cutting process characteristics (cutting wear and deformation wear)
 - Jet dynamic characteristics and energy dissipation (Kinetic energy)
 - System vibration
- Surface roughness values (Pos. 1, Pos. 2, Pos. 3):
 - XROUGH: 2, 2.4, 6.15 μm
 - XFINE: 1.69, 2.1, 3.5 μm
 - High value ranges between settings and measuring positions

Test Results: Tapered Surfaces

Measuring of tapered slots

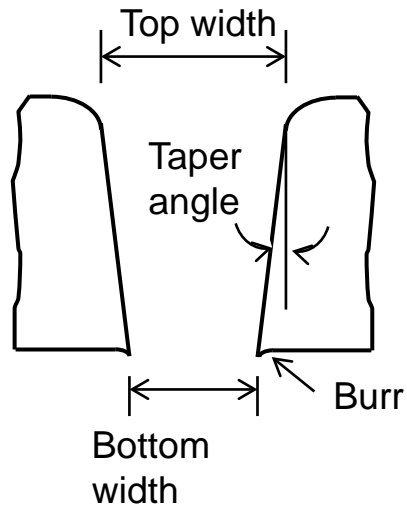

$$T_{\text{ratio}} = \text{Top width} / \text{bottom width}$$

- Characterisation of generated surfaces:
 - Small radius at the top surface
 - Burr at the exit side
 - Taper angle
- Measured tapered ratios T_{ratio} :
 - XROUGH 0.936
 - ROUGH 0.945
 - MEDIUM 0.945
 - FINE 0.948
 - XFINE 0.955

Meet the Challenge through Cutting Head Distortion Simulation

Cutting head

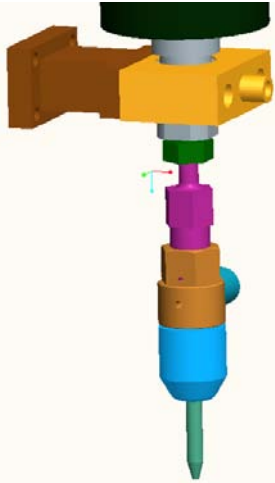

Simulation

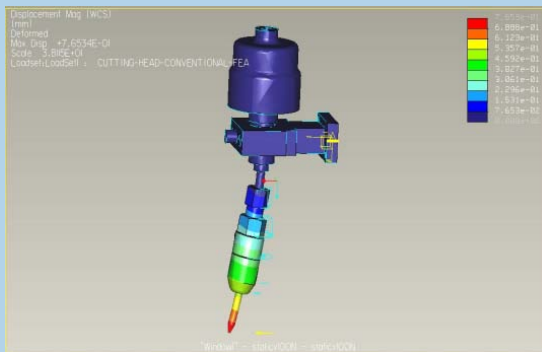

- Simulation for head distortion analysis was set up.
- Simulation results and conclusions:
 - Machining uncertainty produced by conventional cutting head is : 0.2476 mm for position and 0.0005745 rad for orientation.
 - Static stiffness is too low:
 - 130.72 N/mm in x-direction
 - 131.32 N/mm in y-direction
 - First 2 order natural frequencies are low and close (173.6 and 174 Hz) and tend to induce a low frequency vibration.
 - This conventional cutting head is not good enough to be used in this project to achieve a Kerf size 0.3 mm and position error 0.03 mm.
- Precision cutting head design is strongly recommended. Further developments will be followed in forthcoming researches.

Integration of Abrasive Water Jet Machining and High Speed Wire-EDM for Fir Tree Slotting

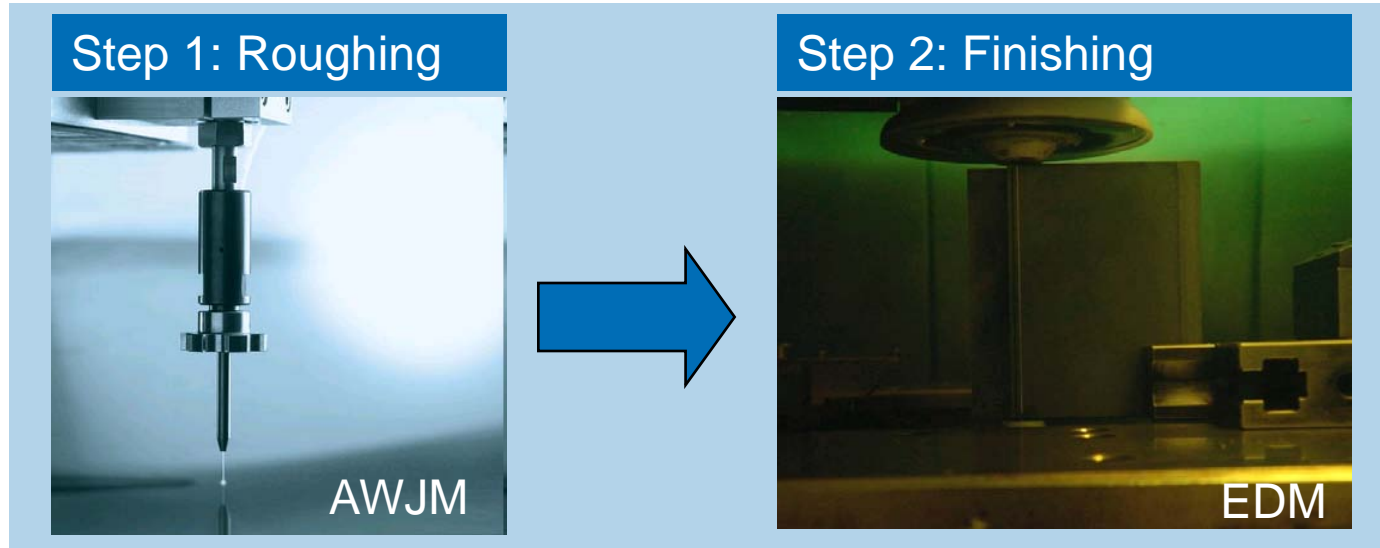

■ Idea:

- Rough cut by AWJM: high productivity
- Trim and finishing cuts by Wire-EDM: good surface finish

■ First results show:

- No difficulties to machine with Wire-EDM after AWJM.
- Demand of additional Wire-EDM cut for removal the taper.
- High completion times of samples.

Outline

- 1 Project Description ADMAP-GAS
- 2 Actual Situation in Fir Tree Production and Challenges for the Future
- 3 Research and Developments on W-EDM and AWJM
- 4 Summary and Outlook

Summary and Outlook

Summary

- Assembling of turbine industry data for researches were carried out.
- Developments show the potential of W-EDM and AWJM for substituting broaching.
 - Precision in W-EDM
 - Cutting rate in AWJM

Outlook

- Further researches on ADMAP-GAS processes.
 - Wire-EDM: increasing of cutting rates
 - AWJM: improving precision
- Life-Cycle-Assessment for manufacturing technology comparison
- Widening from turbine industry to other transport industry through gear manufacturing for sport cars.



ADMAP-GAS

*„Unconventional (Advanced)
Manufacturing Processes for Gas-
Engine Turbine Components“*