

HIGH POWER PIEZOELECTRIC MOTOR FOR BRAKE ACTUATOR - PIBRAC PROJECT

Eric Agostini
SAGEM Défense Sécurité

Keywords: *Piezoelectric, actuator, motor, brake,*

Abstract

Piezoelectric motors are good candidates to replace hydraulics in actuation systems used in aircraft. The PIBRAC project aims at transferring this technology in a real application, an aircraft brake actuator. This paper shows how this technology fits the aircraft actuator constraints and gives a first view on some solutions.

1 Introduction

Last generation aircrafts, like Airbus A380, integrate innovations which make them safer and more economic reducing their operating and maintenance costs.

Another important aspect is their reduced impact on environment as kerosene consumption per passenger per km will be lowered due to a higher payload and better engines.

The major revolution which brings these improvements is the advanced design concept of the "More Electric Aircraft" (MEA) [1]. One important expected change is the integration of electrically powered actuation systems in place of part of hydraulic systems to move flight surface control and to operate brakes.

Hydraulic systems have been widely used since pilot's force were too weak to control aircraft as they became bigger and more and more powerful. This technology has proved to suit very well applications which usually require high torque or force for small displacement and at the same time appeared to be reliable. However, its weaknesses are linked to the use of hydraulic fluids in a wide network of pipes

spread around the aircraft. Safety is impacted by fire hazard and maintenance costs are increased by the need of circuit bleeding after every repairing of any hydraulic element.

Regarding these aspects, first improvements will come from the replacement of hydraulic actuators by electro-hydrostatic actuator (EHA) [2]. These electrically powered devices are essentially small hydraulic pumps with reservoir that transform electrical power into hydraulic power. Part of pipe network is replaced by wires which saves weight and increase safety. They are been widely tested by airframer for control surface actuation and will be used in A380 as back up actuation for flight controls and brakes.

The ultimate objective is to eliminate all hydraulic components through the use of electromechanical actuators (EMA). This equipment is made of an electrical motor and gearbox assembly that moves a ball or roller screw to get a linear movement. These types of actuators have been used on aircrafts for decades for applications requiring low power and/or low response time. They are now available for high power application mainly thanks to the development of high power electronics.

One of these applications, considered for several years, is actuation of the aircraft brakes. The maturity level of this technology makes it possible to be exploited in new aircraft and the Boeing 787 will be the first airliner equipped with electric braking system. Among the expected benefits are a better safety (by eliminating the risk of hydraulic fluid leaks and associated fire hazards), a reduction of operating and maintenance costs and an improvement of

braking efficiency. However, EMA fitted with conventional electromagnetic motor and reduction gears bring a weight increase and a very high electric peak power consumption. The main part of this energy is wasted in the kinetic energy of high inertia motor rotors and reduction gears due to the high frequency of the command of the actuator during anti-skid operation. EMA should be considered as a first step for hydraulic system replacement.

Emerging high power piezoelectric vibration motors are a very promising alternative as they have the potential to gather advantages of hydraulic and EMA technologies.

2. Piezoelectric motor

Piezoelectric actuators have already found numerous applications allowing the miniaturization of low power actuators in commercial products such as camera auto-focus lenses or fuel injectors for car engines [3]. They start being widely used because piezoelectric motors inherently exhibit remarkable performances compared to classical electromagnetic motor:

- High torque at low rotational speed without gear box,
- Low inertia leading to low response time,
- High maintaining torque when powered-off,
- High power to weight ratio.

The graph, (fig.1) hereafter, compares power to weight ratio of hydraulic, electromagnetic and piezoelectric solutions versus achievable power [4].

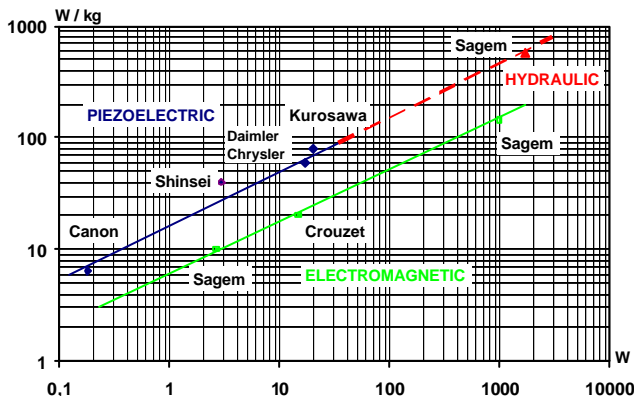

Fig 1 Power density comparison of actuation solutions

The principle of a rotational piezoelectric motor is based on setting in motion a rotor by friction forces induced by a stator. The deformation of the stator due to stress induced by piezoelectric elements may be implemented with various solutions. They all lead to create a progressive wave deformation at the surface of the stator. Fig.2 gives an example of implementation developed by Shinsei and first commercialized in 1986.

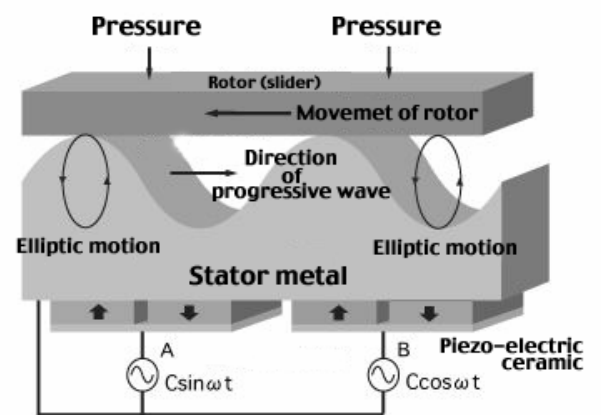

Fig 2 Principle of a progressive wave piezoelectric motor (Shinsei)

The mechanical power range achievable by this type of motor is quite low regarding aircraft applications. For instance, USR60 from Shinsei exhibits a torque up to 1Nm, a maximum speed of 150 rpm and a 5W mechanical power.

Today, an industrialized piezoelectric motor doesn't exist in the kilowatt power range and above. However, the demonstration of a piezoelectric motor feasibility in the kilowatt range has been done through the PAMELA project in the European framework EUREKA [4, 5]. The next step is the implementation of this principle in a real application. It is the objective of the PIBRAC project [6] to demonstrate the feasibility of integrating piezoelectric actuator in aircraft brakes.

3. PIBRAC Project

A highly skilled consortium has been gathered to study, to design and to test an

innovative type of piezoelectric brake actuator and its control electronics during a 3 years EC project funded in the FP6 program. The PIBRAC consortium led by SAGEM DS consists of 11 partners; 4 large industrial companies (SAGEM, AIRBUS, MESSIER-BUGATTI, SKODA), 2 research centres (BAM, INEGI), 4 small & medium size companies (ABRITO, IMMG, NOLIAC, SAMTECH) and 1 university (PADERBORN). This team is focused on proving advantages of piezoelectric technology over EMA technology, developing a brake actuator, a demanding application.

Typically, for a medium size aircraft, the brake actuator piston moves over the brake running clearance of about 3 mm at very high speed but no load before contacting the brake discs and then over about 2 mm when compressing the disc stack and exerting the maximum force on the discs (about 150 –250 kN). Such a brake actuator operates within a large temperature range, between - 55°C, when landing after long high altitude cruise, to +200°C on ground, up to one hour after landing. Additionally, the braking dynamics requirements are very high when the anti-skid is operating, being of about 12 Hz.

The piezoelectric brake actuator must exhibit performances already reached by EMA brake actuator but with improvements regarding system weight and electric power consumption. Indeed the move from hydraulic system to EMA system brings already some advantages like safety improvement or reduction of maintenance cost but at the expense of weight and peak power consumption.

PIBRAC project takes advantages of PAMELA results which led to the design of a high power rotational motor. Part of the work is the adaptation of this piezoelectric motor concept to the brake actuator application. A linear working principle is also investigated but only through modelling and paper studies as it is very innovative and its development couldn't fit PIBRAC framework.

PIBRAC project is divided in 5 work-packages which include specifications and assessment criteria, research on different functions related to piezoelectric components

and their characteristics, technology integration, technology evaluation and management including results dissemination.

Among challenges of this project are the design of a piezoelectric motor which fulfils brake system requirement and the design of power supply very different from those used for electromagnetic motors.

3.1 Rotational motor

Its design is derived from PAMELA motor structure (fig.3a, b), which consists of 4 stator rings pressing two rotors linked to the motor shaft. Stators are composed of several metallic blocks alternating with piezoelectric actuators.

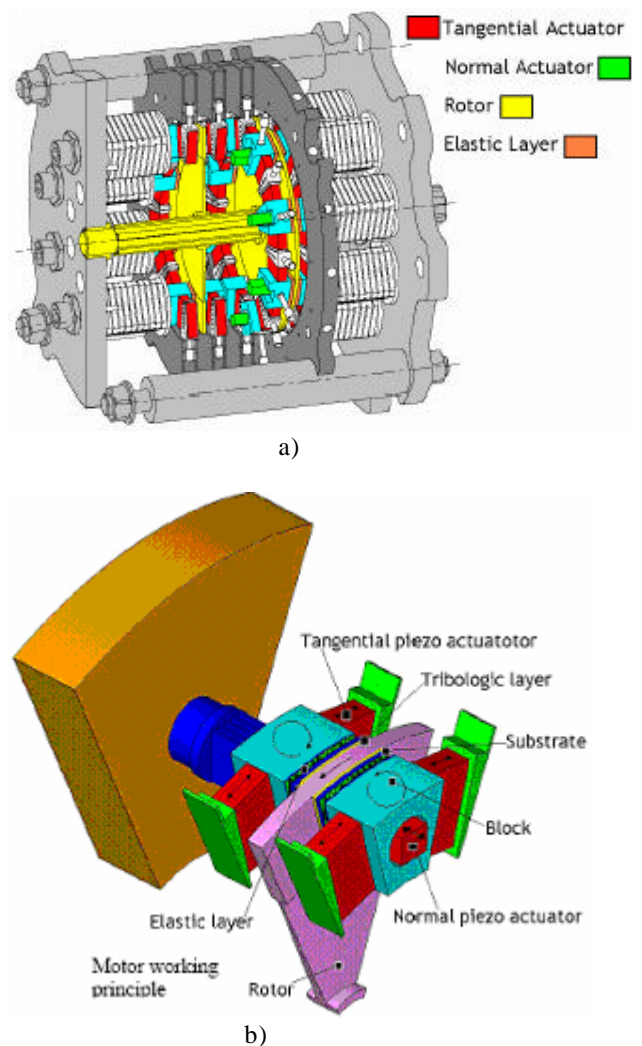

Fig 3 Pamela motor a) structure b) detail of vibration to rotational motion conversion system

These blocks can oscillate circularly (tangential mode) and axially (normal mode). Axial mode is induced by piezoelectric actuators which apply a thrust on metallic blocks in the direction parallel to the motor shaft. The combination of the 2 modes results in an elliptical motion on the contacting surface of the stators and the rotors, which drives the rotor shaft thanks to the friction between the rotor and the stator.

The basic principle is the same (friction induced rotor motion) as for progressive wave motor but this concept give access to 1kW power range which is above a factor 100 of the power provided by classic piezoelectric-motor. Mainly thanks to larger surface contacts which enable conversion of vibration to rotor motion at higher power level.

However the implementation turns out to be more complex. High mechanical power is obtained if the conversion of mechanical vibration is efficiently converted onto rotor motion. That means a perfect control of normal and tangential mode. The motor design must lead to the same mechanical resonance frequency for the 2 modes and the respective power supplies of normal and tangential piezoelectric actuators must be perfectly tuned to get the proper motion of metallic blocks. The second important feature which has a strong impact on conversion efficiency is the contact dynamics between stator and rotor; the power transmitted being linked to the total surface contact and friction coefficient between rotor and stator materials.

3.2 Power Controller

The power electronic transforms electric power from the aircraft power supply to an appropriate level of voltage in ultra sonic frequency (270VAC~40kHz) (fig.4). This is done through a PWM inverter followed by an efficient filtering. Two separate power lines feed tangential and normal piezoelectric actuator with a defined phase relation to get an efficient motion of metallic blocks. The

capacitive nature of piezoelectric actuators and their electrical behaviour strongly frequency-dependent on their interactions with the mechanical load bring the necessity of a control loop at motor level. A control loop at system level takes in account functionalities required by the objectives of brake control.

The choice of power converter topology conditions features like weight and efficiency. Special care is taken on filter design which must ensure, aside an efficient filtering of harmonic content of electrical power fed in piezoelectric actuator through a wide temperature range, a reasonable inductance weight.

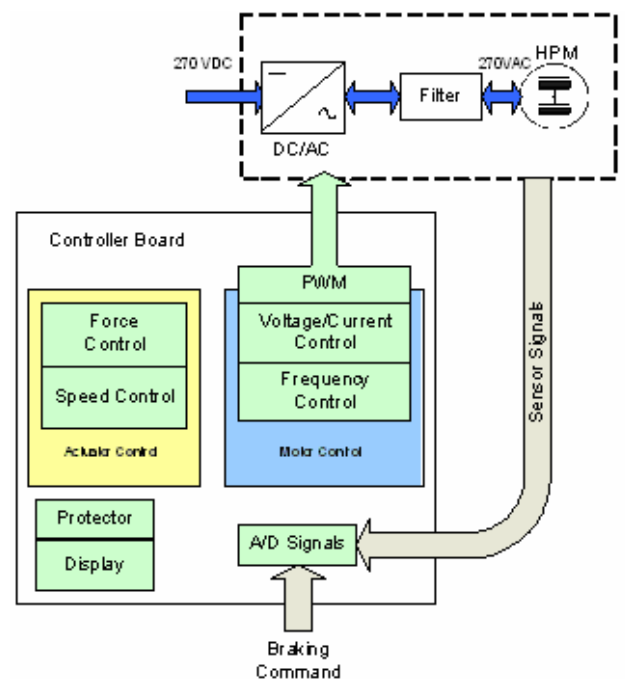

Fig 4 Power converter with motor control scheme

3.3 Material studies

Brake operation occurs several time during a flight cycle, e.g. during landing, taxi, park. Considering 50000 flight cycles during aircraft time life, this leads to a cycle number at metallic block level of about 10^{11} . Motor parts which undergo highest stress level are piezoelectric actuators and rotor/stator interface materials. Motor life time could be impacted by fatigue resistance of piezoelectric actuator or wear rate level of interface materials.

As very little knowledge exists on these subjects, part of the work is dedicated to investigate behaviour and fatigue of different piezoelectric materials, for selecting most promising ones and likewise a research is conducted on appropriate materials which must exhibit high friction coefficient and at the same time withstand to wear.

These analyses require development of new testing devices. Piezoelectric materials are fatigue tested on a new machine specifically designed for PIBRAC which apply high stress level (up to 50MPa), at large temperature range (-55°C to 200°C) and at a frequency close to the mechanical resonance.

Materials for rotor/stator interface will be selected depending on their tribological properties. However, these data are known for frequency below 2 kHz, when they are available. A specific tribometer has been designed to test candidate materials at high frequency (up to 40kHz). Frictional and wear behaviour will be mapped as functions of relative humidity level (2% to 98%) and temperature.

The knowledge of material behaviour under stress is of primary importance as they impact motor performances and its time life. Results obtained in PIBRAC framework will be insight for further intensive qualification.

3.4 Mechanical function

PIBRAC objective is not as simple as an electromagnetic replacement by a piezoelectric one in a brake actuator. Its specific electrical to mechanical power conversion principle leads to design and develop new mechanical interface solutions with the brake. First, the fact it can provide high torque level at low rotational speed allows removing the heavy reduction gear box. The mechanical power is directly transmitted to the piston through a classical ball or roller screw. It must be noticed that with a linear piezoelectric motor this function will not be necessary anymore as it works like a jack.

The other distinctive feature is its ability to stay locked when it is powered-off. Thus a

specific device for the parking brake function is no longer necessary. However due to this characteristic, the reversibility of the brake is not ensured. As a brake must stay unlocked in case of power supply loss to avoid risk of wheel skid, this situation is not acceptable. This safety requirement is recovered inserting a clutch in the cinematic line between motor shaft and the piston. The definition of this component is not straightforward as it must bear a very high torque level.

3.5 Modelling

To support design activities, a large part of PIBRAC is dedicated to perform modelling at different steps of the project. First, motor design is sized extrapolating PAMELA project results. The investigation of the influence of the different geometrical parameters of the motor (overall dimensions, operating voltage,...) on output performances is carried out using an analytical model, in a Matlab-Simulink, environment and taking into account piezoelectric and tribologic material limits. Then, a theoretical analysis based on the finite element modelling (FEM) is conducted to optimize the design. At this stage, tangential and normal mode behaviours are optimized to get the highest level of mechanical power.

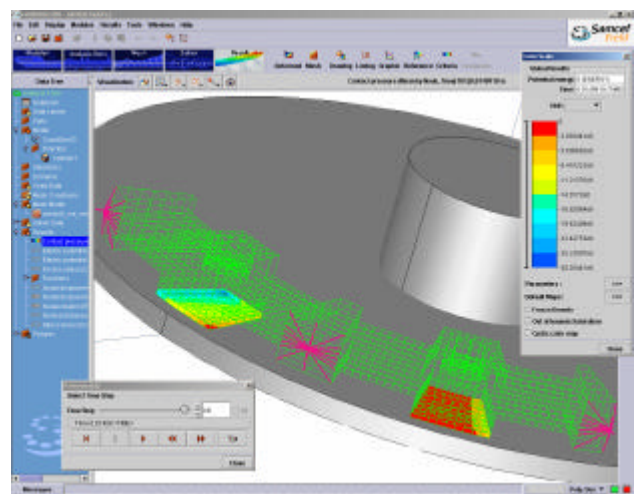

Fig 5 Dynamic simulation of contact pressure

The mechanical conversion efficiency from high frequency electrical excitation of piezoelectric actuators to continuous movement

of the rotor thanks to friction effect is also optimized using a non-linear dynamic model (Fig.5). An efficiency exceeding 50% is targeted. In parallel to mechanical design, power supply and control strategies are investigated through modelling using an equivalent circuit of the motor.

When all design tasks will be completed, a mechatronic analysis of the overall brake actuator including motor actuator sensors and actuator control loop models will be performed and used to carry out final tuning of the actuator when it will be available at the end of the project.

4. Conclusions

The move toward the More Electric Aircraft has already started through progressive replacement of part of hydraulic actuators by electromagnetic actuators. A more advanced innovation will be the use of actuators based on piezoelectric technology. Their main features fit very well requirements for aircraft brake actuators as they exhibit high torque level at low speed, a low inertia giving low response time and a high power to weight ratio compared to EMA. To demonstrate the advantages of this technology, this application was selected for the European project PIBRAC. Aside the design of a specific piezoelectric motor which takes advantage of the former European project PAMELA, a large part of the work is devoted to material selection to ensure life time requirement, to design a specific control electronic which adapts motor control law with brake objectives and to design a mechanical interface with the brake. All this work is supported by intensive modelling and will be validated through tests on demonstrator.

Acknowledgement

Author would like to thank the European Community for funding the PIBRAC project under AST4-CT-2005-516111 and as well PIBRAC Consortium partners.

- [1] D Van den Bossche. More Electric Control Surface Actuation – A Standard for the Next Generation of Transport Aircraft. *EADS International Technology Days*, Paris November 2003.
- [2] Mohsen Torabzadeh-Tari. Analysis of Electro-Mechanical Actuator Systems in More Electric Aircraft Applications. *Thesis, Royal Institute of Technology Sweden*, 2005.
- [3] Hans-Peter Schöner. Automotive applications of Unconventional Actuators. *MAGELEC* 2001.
- [4] F. Hodar, E. Merlet, JT. Audren. Conception et essai d'un moteur piézo-électrique haute puissance. *MAGELEC* 2001.
- [5] Piezo Active Motors for more ELelectric Aircraft PAMELA2 Eureka Project EU1978
- [6] www.pibrac.org