

# PROJECT FINAL REPORT

**Grant Agreement number: 218447**

**Project acronym: INGAS**

**Project title: Integrated GAS Powertrain – Low emissions, CO<sub>2</sub> optimised and efficient CNG engines for passenger cars (PC) and light duty vehicles (LDV)**

**Funding Scheme: FP7-SST-2007-RTD-1**

**Period covered: from October the 1<sup>st</sup> 2008 to March the 31<sup>st</sup> 2012**

**Name of the scientific representative of the project's co-ordinator<sup>1</sup>, Title and Organisation:**

**Massimo Ferrera, Dr., Centro Ricerche FIAT**

**Tel: +39-0119083528**

**Fax: +39-01189083647**

**E-mail: [massimo.ferrera@fptpowertrain.crf.it](mailto:massimo.ferrera@fptpowertrain.crf.it)**

**Project website address: <http://www.ingas-eu.org/>**

---

<sup>1</sup> Usually the contact person of the coordinator as specified in Art. 8.1. of the Grant Agreement.

# INDEX

1. Final publishable summary report.....	3
1.1 Executive Summary .....	3
1.2 Project context and objectives.....	4
1.3 Main S&T results/foregrounds.....	9
1.4 Potential Impact.....	41
1.6 Project website address .....	44
2. Use and dissemination of foreground .....	45
Section A.....	45
Section B .....	55
3. Report on societal implications .....	62

# 1. Final publishable summary report

## 1.1 Executive Summary

All innovative technologies developed in the INGAS Project for Natural Gas engine/vehicle have been integrated according to n.3 technology ways as follows:

Tech. way	Engine displacement litres	Max Power kW	Max Torque Nm	Combustion approach	Compression ratio	Air management	Injection system	ATS	Demo vehicle Segment
1	1,4 - 4 cyl.	104	230	Stoichiometric	11:1	VVA+VGT	PFI	3 way	C
2	1,8 - 4cyl.	126	300	Stoichiometric	12:1	Mech.+TC WG	DI	3 way	D
3	1,6 – 4 cyl.	90	270	Lean burn	12:1	Mech+TC 2 stage	PFI	OC+SCR	LCV

List of acronyms:

VVA = Variable Valve Actuation system

VGT = Variable Geometry Turbine

Mech. = Mechanical Valve Actuation

TC WG = Dedicated Waste gate Turbocharger

TC 2 stage = Waste gate Turbocharger 2 stage

PFI = Port fuel injection

DI = Direct injection

3 way = 3 way catalyst

OC+SCR = Oxidant catalyst + Selective Catalyst Reducer + Ammonia injection & sensor.

The main outcomes of the project are listed below:

- 1) validator vehicle Fiat Bravo with innovative 1.4 l TC PFI Multiair stoichiometric CNG engine adopting technology way 1
- 2) validator vehicle Mercedes E 200 NGT with innovative 1.8 l TC DI stoichiometric CNG engine adopting technology way 2 and start-stop device
- 3) after treatment for innovative 1.6 l TC PFI lean burn CNG engine adopting technology way 3
- 4) full WTT and combustion analysis vs NG composition and innovative NG quality sensor
- 5) innovative CNG storage module implemented on B-segment Fiat Grande Punto with 1.4 l CNG engine
- 6) innovative after treatment as improved 3-way catalyst with lower precious metal content than conventional one and heat exchanger to enhance methane conversion efficiency.

According to main outcomes of the project, the relevant results can be summarized in the following way:

- 1) engine performance are superior adopting technology ways 1 and 2 thanks to improved low end torque, adopting VVA+VGT system the torque is enhanced even if a better turbo matching could improve this figure, instead adopting DI+TC WG system the scavenging effect is fully exploited reaching very impressive torque at low engine speed. In any case adopting technology ways 1 or 2 the gap of CNG engine compared to Diesel or gasoline ones in terms of low end torque and rated power is fully removed
- 2) CO<sub>2</sub> and fuel consumption have been improved compared to current CNG engines thanks to the adoption of air management system able to apply the downsizing concept shifting the engine operating area versus lowest break specific fuel consumption zone. The accounted reduction is close to 16% adopting technology way 1 and 2 and 10% adopting technology way 3
- 3) emissions figures have put in evidence that Particle matter, Particle number, NMOG (not methane organic gases) and NMHC are not issues for Natural Gas Engines according to

measurement performed in the project, the absolute results are one order of magnitude lower than foreseen Euro 6 or Euro 6+ limits/targets.. Ammonia emitted is lower than smell threshold. Global warming index that measures Green House Gases effect is at last 3% higher than CO<sub>2</sub> figures due to low amount of CH<sub>4</sub> emitted. CO and NO<sub>x</sub> emissions have fulfilled INGAS targets equal to half of Euro 6 limits. Instead only technology way 1 fully comply INGAS target in terms of THC, technology way 2 has encountered problem of injector stability influencing THC conversion efficiency and technology way 3 failed the targets according to simulation performed.

- 4) Real life cycle compared to has put in evidence an increase in terms of CO<sub>2</sub> (up to 8%) and emissions. CO<sub>2</sub> increases more for engine with lower displacement as expected and emissions of CO and NO<sub>x</sub> are always below EURO 5/6 limits. Issues remains in terms of THC emissions only for technology ways 2 and 3.
- 5) Natural Gas composition can be managed by means of dedicated strategy implement into ECU and gas quality sensor compensating influence versus combustion behavior and conversion efficiency of after treatment.
- 6) The improved 3-way catalyst has a synergic effect in terms of simultaneous reduction of precious noble metal (-30% cost) and increase in terms of CH<sub>4</sub> light off performance (CH<sub>4</sub> light off temperature reduction -60°C means at least -30% CH<sub>4</sub> tailpipe)
- 7) The innovative storage system provide halved weight compare to conventional solutions without any penalty in terms of vehicle trunk space / comfort ability and safety and a moderate cost increase (+20%)
- 8) The estimate increase of cost of integrated technologies into technology way 1 and 2 (+20%) can be easily compensated by benefits achieved. Instead it's questionable if cost / benefit trade-off is positive adopting lean burn approach due to relevant cost increase of very complex after treatment.
- 9) Thanks to technology ways developed in the project and the adoption of 65% of bio methane instead of fossil CNG a WTW figure equal to zero can be easily achieved.

## 1.2 Project context and objectives

### Project context

Natural gas (NG) vehicles were introduced on the market more than 10 years ago. Nevertheless, today's market share of compressed natural gas (CNG) vehicles is relatively small but rapidly increasing. But, today's gas engines have the heavy drawback of being developed as multi-fuel engines out of conventional gasoline fuelled combustion engines. Optimized gas technology development suffers under the insufficient infrastructure of filling stations resulting in a clear reduced operation field of CNG mono-fuel vehicles which reduces the acceptance of the end customer. This aspect is additionally overlaid by the challenging storage requirements for gaseous fuels. So, all series vehicles use are based on gasoline engine not designed and optimized for CNG. The market introduction of dedicated (mono-fuel) CNG vehicles requires the development of technologies able to solve problems concerning gas storage, gas feeding, combustion system and aftertreatment and, at the same time, to take into account the quality of natural gas.

From the point of the security of energy supply, natural gas (NG) represents a real alternative to crude oil being available in large quantities also in countries different from the Middle East. If reserves/production ratio is considered, there are ample world reserves of natural gas for the next 65.1 years, higher than those of crude oil (40.6 years), sufficient to allow significant use of NG to power transportation vehicles.

Natural gas is a clean fuel. Leaving out the entire elimination of evaporative emissions in Compressed Natural Gas (CNG) vehicles because of pressurized gas feeding lines even during refuelling, in natural gas, toxic compounds, like sulfur, or potentially toxic, like benzene and higher molecular weight hydrocarbons, or highly reactive such as olefins are absent. Furthermore, the

extremely compact molecule of methane, that is the primary constituent of natural gas (from 85% to 95% by volume depending on the different sources), means also a high oxidation stability that strongly opposes the radical degradation in the combustion environment. As a consequence 90-95% of unburned hydrocarbons exhausted by a NG engine is still represented by methane, while toxic organic compounds such as irritant higher aldehydes, 1-3 butadiene, benzene and polycyclic aromatic hydrocarbons are absolutely negligible or nonexistent at all. Because of its strong resistance to radical degradation, the reactivity of methane to form atmospheric ozone is trivial; thus, its potential of ozone formation is very low.

EC activities on alternative fuels have two policy drivers: the security of energy supply (Energy Green Paper 11/2000) and the reduction of greenhouse gas emissions (Transport White Paper 9/2001) as energy efficiency and alternative fuels are complementary approaches. The use of natural gas as a fuel for vehicles was considered in a number of documents such as the EC Communication on alternative fuels (11/2001) where biofuels, natural gas and hydrogen are identified as the three main candidates, the contact group on alternative fuels (Report 12/2003) attended by stakeholder experts on technology and economics. More recently the use of natural gas has been examined in a study committed by EC DG Enterprise in preparation of a new strategy aimed at reducing the CO<sub>2</sub> emissions of light-duty vehicles to a level of 120 g/km in 2012. The highest hydrogen content of methane molecule, with respect to any other hydrocarbon based fuel, allows to achieve a substantial reduction of the carbon dioxide (CO<sub>2</sub>) exhausted by NG vehicles of about 23% compared to gasoline. Even if considering the higher greenhouse potential associated to methane (23 time more than CO<sub>2</sub> when considered in a time horizon of 100 years), the Global Warming Index (GWI) still confirms the advantage of NG vehicles.

### **Project objectives**

The objective of the Collaborative Project “Integrated gas powertrain (InGas)” is to deploy a custom designed engine integrated with specific aftertreatment systems applied to a light duty (LD) vehicle able to achieve a 10% higher fuel conversion efficiency than that of a corresponding 2006 diesel vehicle and complying with an emission level lower than Euro 6. Additional features are advanced storage systems and vehicle architectures, as well as multi-grade fuel tolerance and fuel flexibility.

- While the gasoline and diesel fuel characteristics depend on the refining / synthesis process, the natural gas quality depends on the source of extraction . The different types of natural gas are characterized today as high (H-gas) quality and low (L-gas) quality depending on the level of the heating value. Reflecting the heating value, in Europe the natural gas composition can be assumed between the high quality reference gas G20 (pure methane) and the low quality reference gas G25 (methane + 14% of inert as N<sub>2</sub>). Reflecting further gas properties like knocking behaviour or density, other limit gases are relevant. The gas composition has to be clearly defined because affecting the storage system, the combustion and the aftertreatment. The project will consider not only natural gases of different composition but also mixtures of natural gas with biogas and with hydrogen (H<sub>2</sub>). A multi-grade fuel tolerance and a high fuel flexibility have to be assured by adopting specific technologies of gas feeding and combustion control systems.
- Natural gas requires an advanced, purpose-designed storage system able to guarantee a range equivalent to that of a conventional vehicle, while maintaining a sufficient vehicle trunk capacity achieved by appropriate vehicle architecture.
- The combustion system shall enjoy the high octane number of methane and the other natural gas characteristics by adopting specific technologies to be verified in engines characterized by different total displacement (low with 1.4 liters and medium with 1.8 liters) and different applications (passenger cars and light commercials) aimed to achieve a very high efficiency under different driving conditions. First point to be addressed by the development of the CNG combustion system is the very challenging target of a 10% higher

fuel conversion efficiency than that of a 2006 diesel engine both as max fuel conversion efficiency and at part load operations (e.g.: BMEP = 4 bar and 3000 rpm).

- In the position of the European Parliament (EP), the nature of NG light duty (LD) vehicles emissions has been taken into account by introducing for the first time two separate standards of total hydrocarbons (THC) and non-methane hydrocarbons (NMHC). Since long time an emission limit on Non-Methane Organic Gases (NMOG) is considered in USA. The ultra-low emission target of the project: pollutant emission limits lower than Euro 6 and Tier II, leaving out PM that being absolutely negligible in the exhaust of vehicles running on natural gas can't be measured. To be fuel neutral, i.e. applicable to gasoline, diesel and all other fuels as it was the intention of the US regulation, these standards have to be complemented by the Global Warming Index ( $GWI = CO_2 + 62 \times CH_4$ ) determined in the most severe time horizon of 20 years. GWI is more appropriate than the  $CH_4$  cap, represented by the difference between total hydrocarbons (THC) and non-methane hydrocarbons (NMHC) of the EU regulation, to evaluate the greenhouse influence of a given fuel / powertrain: in this sense the GWI is a really fuel neutral parameter applicable to all fuels.

The catalyst up to now developed, specific for NG vehicles, can meet the emissions limits both when the vehicle is new (0 km) and under durability, but with a sensible cost increase with respect to the corresponding conventional catalyst used in gasoline vehicles. The main duty of an advanced catalyst technology for CNG vehicles would be the development of dedicated methane catalyst, i.e. catalysts which for formulation and limited use of precious metal with higher conversion efficiency (respect to gasoline vehicle catalyst ones) at similar or lower level of cost. The catalytic system has to account also other types of combustion process than the stoichiometric one until now developed.

*Table 1 – General targets*

	Euro 6 limits	INGAS emission target
Durability [km]	160.000	160.000 (compliance by analysis)
THC [mg/km]	100	100
NMHC [mg/km]	68	45
NMOG [mg/km]		45
CO [mg/km]	1000	1000
NOx [mg/km]	60	30
PM [mg/km]	5	< 5
GWl on NEDC		reduction of 20% respect to ICE fuelled by conventional fuels

- The final objective is the assessment of well-to-tank (WTT) energy consumption as first step to arrive at the end to well-to-wheel (WTW) evaluation passing through the tank-to-wheel (TTW) energy related to the given technology way.

**Sub Project A1 “CNG technologies for passenger cars”** deals with the development of a natural gas car powered by a 1.4 liter displacement engine by adopting the innovative technology of variable valve management on stoichiometric combustion / sequential multi-point port gas injection approach. After the base engine development the development and calibration of the engine control system and the combustion process investigation will allow to obtain projections on vehicle performance (fun-to-drive), emissions and fuel consumption to be compared with project objectives.

*Table A1 - Specific targets of SP A1 for 1.4 liter displacement car belonging to the C segment*

	State of the art	Target
Max power density	~ 45 kW/l	> 65 kW/l
Max torque density	~ 85 Nm/l	> 130 N·m/l
CO <sub>2</sub> emission on NEDC test cycle	~ 150 g/km	< 130 g/km

**Sub Project A2 “Turbo DI CNG engine”** deals with the development of a natural gas car powered by a 1.8 liter displacement engine by adopting the innovative technology of direct gas in-cylinder injection for stoichiometric and stratified lean burn approach with (in the case of stratified combustion a very high air excess ratio lambda is achievable). After the definition of the engine layout, a particular care will be devoted to the development and hardware procurement of a gas injection system that for performance, injector stability and size is compatible with the selected engine.

*Table A2 - Specific targets of SPA2 for the 1.8 liter displacement car belonging to a D segment*

Engine Torque	State of the art	Target
Max power density @ 4300 – 5500 rpm	~ 45 kW/l	> 70 kW/l
Max torque density @ 1800 – 4300 rpm	~ 85 Nm/l	> 160 N·m/l
CO <sub>2</sub> emission on NEDC test cycle	~ 170 g/km	< 140 g/km

**Sub Project A3 “Boosted lean burn gas engine”** deals with the development of a natural gas light-duty vehicle powered by a 1.9 liter displacement engine adopting an innovative over-boosted ultra-lean combustion system, i.e. able to achieve an air excess ratio lambda between 1.35 and 1.6, using port gas injection (at first) or low pressure direct gas injection (if the port gas injection is not sufficient). After a first phase of concept phase and design specifications, the engine components procurement will carefully consider the balance between components specifications and costs.

*Table A3 Specific targets of subproject A3 for 1.6 liter displacement LD vehicle*

	State of the art	Target
Max power density	~ 47 kW/l	> 60 kW/l
Max torque density	~ 90 Nm/l	> 160 Nm/l
CO <sub>2</sub> emission on NEDC	~ 140 g/km	< 110 g/km

**Sub Project B0 “Fuels for advanced CNG engines”** deals with the definition and the supply the gas mixture of the requested quality to the other sub-projects. In doing such an activity the sub-project B0 will conduct analyses and propose solutions in order to affect in a flexible way storage, combustion, aftertreatment and performance of the CNG vehicles.

**Sub Project B1 “Gas storage for passenger car CNG engine”** deals with the development of advanced gas storage and filling systems including specific components and gas sensors, in correspondence with the target of achieving a vehicle range in the more than 500 km.

*Table B1 – Fuel & vehicle targets*

	Today NG vehicles	INGAS Project target
Gas composition	G20 (100% CH <sub>4</sub> ) ÷ G25 (14% inert as N <sub>2</sub> )	Matrix of limit gases defined within the SP B0
Fuel flexibility	Homologation with G20 and G25	Full compatibility with commercial NG + Biomethane + NG / H <sub>2</sub> blends (up to 20-30% by volume)
Tank mass / vehicle range	+ 150 kg/350 km (steel) + 200 kg/500 km (steel)	+ 160 kg/500 km (composite)
Vehicle range	250 (bifuel) ÷ 400 km (monofuel)	500 km (monofuel) <sup>a)</sup>
Vehicle capacity via a specific architecture adopting a not intrusive tank location	Just adaptation to the pre-existing gasoline vehicle	Vehicle trunk capacity reduction not higher than 10%
CH <sub>4</sub> conversion efficiency at a given catalyst cost	80% < on 100.000 km durability	> 90% on 160.000 km with possible lower catalyst cost
Fun-to-drive (expressed by torque output)	12% less than the corresponding NA gasoline engine vehicle or equivalent in case of boosted engines	Equivalent to the corresponding 2006 diesel vehicle

**Sub Project B2 “Aftertreatment for passenger car CNG engine”** deals with the development of an aftertreatment system for natural gas vehicles having special regards to CH<sub>4</sub> conversion efficiency and NO<sub>x</sub> abatement under lean combustion operations. It is not only a matter of achieving a high CH<sub>4</sub> conversion efficiency (> 90% on 160.000 km with lower cost than today catalyst but also of developing the innovative catalyst system able to support the completely different combustion approaches of the three technology ways.

*Table B2 - Specific targets of SPB2*

	State of the art	Target
HC conversion ( $\square=1$ )	90% (bivalent)	90% (monovalent)
CH <sub>4</sub> lightoff temperature ( $\square=1$ )	400°C	330°C
NO <sub>x</sub> conversion ( $\square>1$ )	No value	>50%

The outcome of the SP A1, A2 and A3 is interpreted via the Tank-to-Wheels (TtW) assessment of natural gases of different quality and gaseous fuel mixtures including biomethane and hydrogen with natural gas. All the three Sub-Projects represent the ultimate research effort to realize a gas light-duty vehicle reaching the best compromise between market expectations, EU Community targets and costs, that at the end will decide about the exploitation of the research.



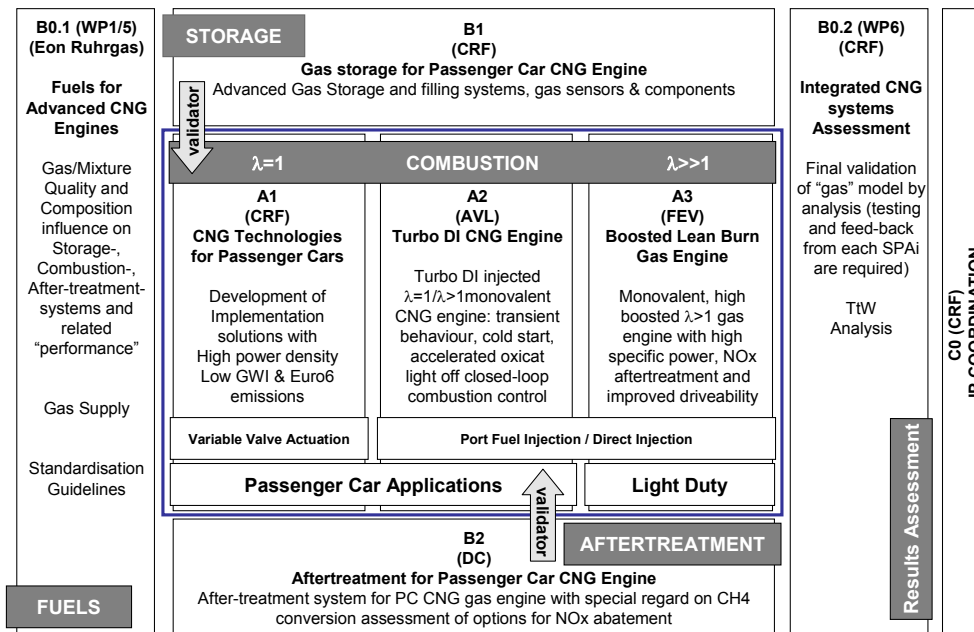

## 1.3 Main S&T results/foregrounds

### Sub Project A1 - CNG technologies for passenger cars

#### General objectives and contents

The focus of SP A1 was the development of a downsized turbocharged CNG engine integrating an innovative system for the intake valve actuation and based on the stoichiometric combustion approach. The development activities on the engine have been supported by a detailed simulation phase devoted to the definition of the engine configuration in terms of intake/exhaust camshaft profiles, engine compression ratio and turbo matching. Combustion process has been also investigated using, on one side, optical devices to describe the air/fuel mixing process and to determine the combustion behaviour using different fuels including natural gas/hydrogen blends; on the other side, a specific focus has been done on the heat release determination at the engine test bench on a multi-cylinder CNG engine, investigating also the potential in using external EGR coupled with natural gas/hydrogen blends.

The engine control system, integrating both the variable valve actuation system strategies and the CNG dedicated ones, has included also the contribution from the electronic pressure regulator developed in SP B1 as well as an innovative gas quality sensor (developed in SP B0) integrated on engine at test bench and on the validator vehicle to perform several measurements with different kinds of gas composition.

In parallel a specific Work Package has been devoted to the development of the appropriate after-treatment technology, based on the trivalent catalysis, and taking into account the critical aspects related to methane conversion at low temperatures in relationship with the ambitious target of the project (close to the half of the Euro 6 limits).

During the last phase of the project, a validator vehicle, representative of the C-segment, has been prepared to integrate the prototype engine and a dedicated CNG storage system, composed with Type IV vessels and inner valves developed within SP B0, to assess the technology performance in terms of fun-to-drive, driveability, fuel economy, pollutant emissions, and vehicle range.

## Project results

A complete air path simulation model has been developed by IFPEN to predict engine performance, also in relationship with activities carried out in CRF on intake/exhaust distribution, to determine the best configuration for the turbocharger group, represented by a VGT (variable geometry turbine) model with the aim to optimize energy conversion on a wider operating field.

3D combustion model has been also developed to support the experimental activities oriented to the determination of the engine combustion chamber geometry and compression ratio (see Figure A1.1). Calculations and experimental validation have indicated the capability to manage a CR equal to 11:1 (plus turbocharging) even when running with natural gas/hydrogen blends (having a lower RON value compared to pure NG).

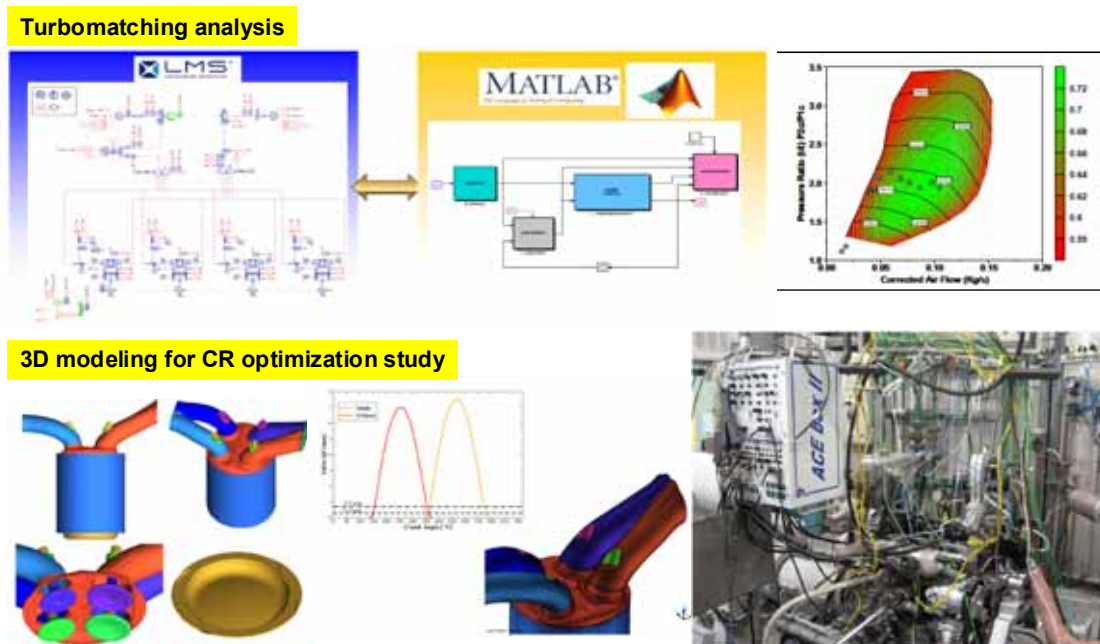

Fig. A1.1 – Simulation models supporting the engine development

Under this configuration a maximum torque of 230 Nm is attained at 1900 rpm, corresponding to a specific value of 164 Nm/dm<sup>3</sup>, and a maximum power output of 104 kW (141 CV) at 5000 rpm corresponding to 74 kW/dm<sup>3</sup>, fulfilling the preliminary INGAS project targets. A maximum engine thermal efficiency by 36% has been achieved.

The work on the multi-cylinder engine has been supported by the investigations carried out by TU Graz on an optical single-cylinder engine where the influence of hydrogen blending into methane has been studied from the point of view of the combustion process. Figure A1.2 shows a significant influence of the hydrogen content on the determination of the combustion delay especially when operating under lean burn conditions where even a 10% by volume H<sub>2</sub> blend shows a shorter delay in starting the combustion process.

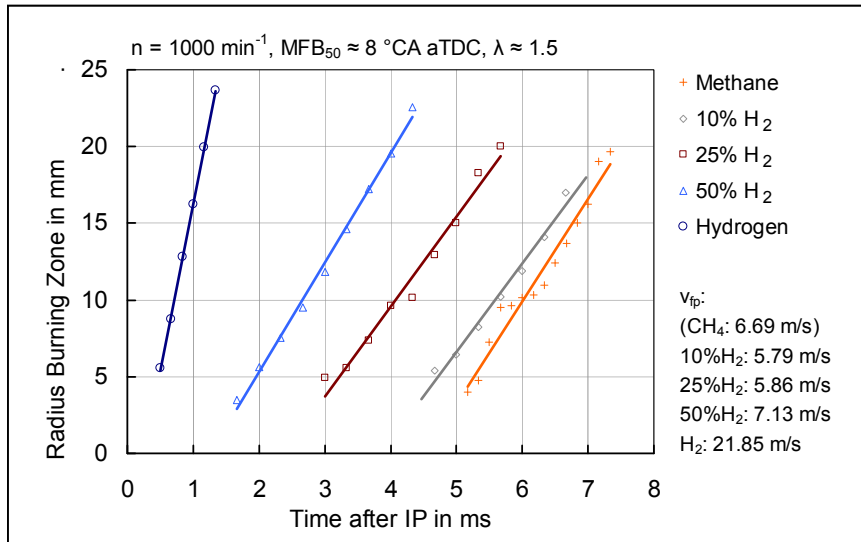

Fig. A1.2 – Optical measurement of the combustion process with different methane/hydrogen blends

Investigations have been completed by CNR IM through a dedicated multi-cylinder engine where the influence of hydrogen as a flame speed promoter has been characterized through the analysis of the in-cylinder pressure measurement and confirming the influence of hydrogen with regards to combustion process initiation (incubation time). Moreover, combustion process results more complete when using natural gas/hydrogen blend, and a significant reduction in THC formation is observed over the corresponding effect only due to the reduction of the carbon fraction in the fuel (Figure A1.3).

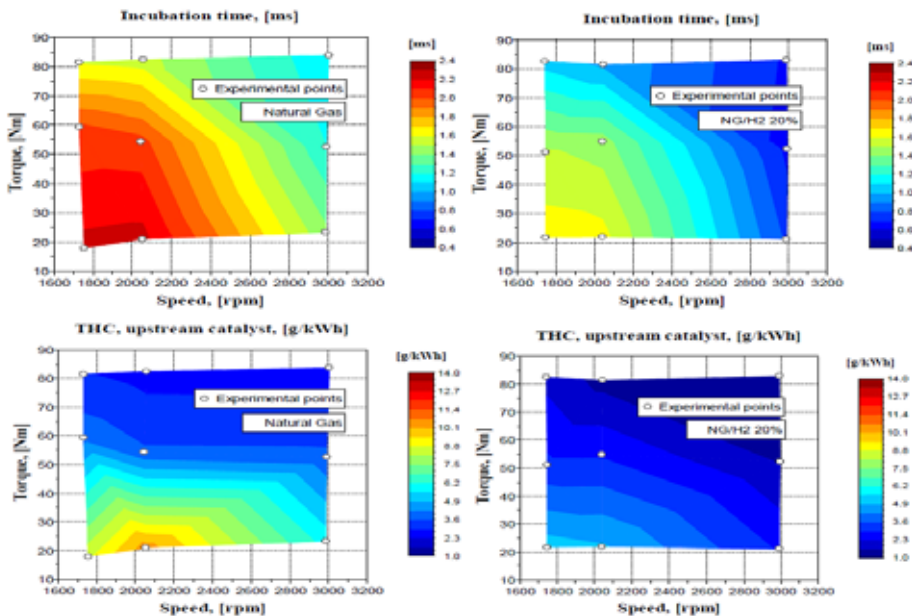

Fig. A1.3 Incubation time and THC emissions for NG, NG/H<sub>2</sub> 20% and NG/H<sub>2</sub> 40% blends at different engine speed and torque.

On the injection side, a dedicated optical device has been set up by TU Graz to perform the analysis of the air-fuel mixing process, taking into account the orientation of the injector flow with

regards to the air motion axle and the opportunity to operate under variable pressure conditions. This aspect has been also considered for the choice of the gas injector to be used for the development of the engine.

Concerning the development of the after-treatment system, both the substrate and the washcoat optimizations have been considered by ECOCAT to provide the best trade off among low back-pressure characteristics and fast light off conditions and considering the project emission targets also with aged components representative of a 160.000 km mileage. Screening test have been performed at the laboratory scale and on a mule CNG vehicle in order to assess the behavior of a first proposal in terms of precious metal loading, considering Pd:Rh and Pd-only formulations.

Samples have been realized using an advanced and innovative substrate able to increase flow turbulence and heat exchange for enhancing fast light-off operations, and supplied to IFP EN for testing on engine with regards to conversion efficiency windows and light off behavior. The best formulation has been used to prepare the exhaust line to be integrated onto the validator vehicle for final assessment beside CRF. Figure A1.4 shows the innovative substrate geometry developed within the project and the performance obtained in terms of THC conversion and light off behavior and, finally, the integration of the sample on the vehicle engine.

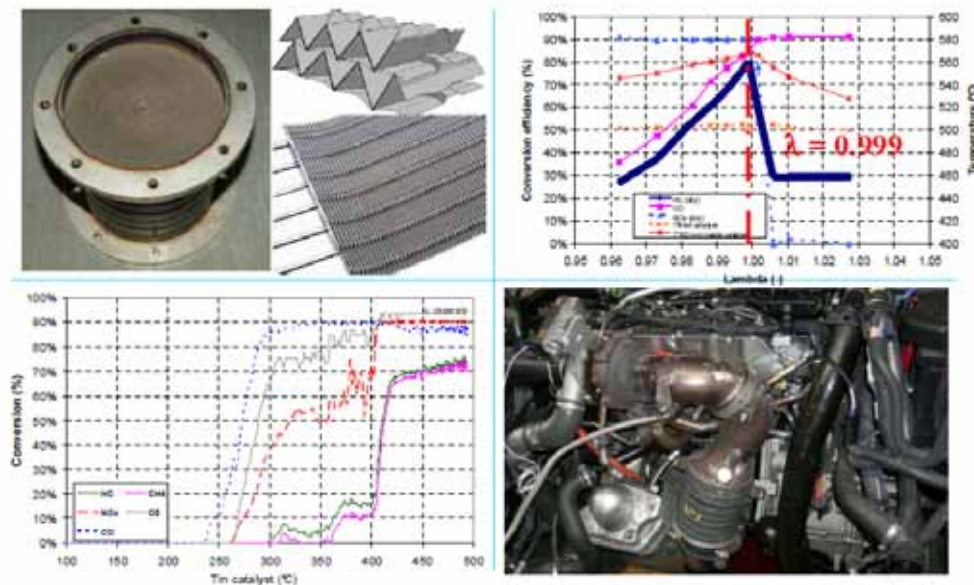

Fig. A1.4 – 3-ways CNG catalyst development

Concerning the validator vehicle a Fiat Bravo has been retained as representative of the C-segment class and the procured vehicle has been modified in the rear part to integrate n.5 Type IV gas vessels, for an overall tank capacity by 130 liters, that have been designed to guarantee the required vehicle range of 500 km (Figure A1.5). The final configuration of the vehicle results in a Standard A weight by 1444 kg.



Fig. A1.5: Underfloor integration of the gas storage system

Vehicle has been completely tuned to comply with all the criteria required by the project and then assessed at the rolling chassis dynamometer and at the proving ground.

As far as concerns the pollutant emissions, activities have been carried out referring on both NEDC test conditions and mission profile representative of the real operative conditions of the vehicle, to quantify the sensitivity of the technology to the driving parameters. Figure A1.6 shows the final results obtained over the NEDC homologation cycle comparing data with INGAS targets and EURO 6 limit.

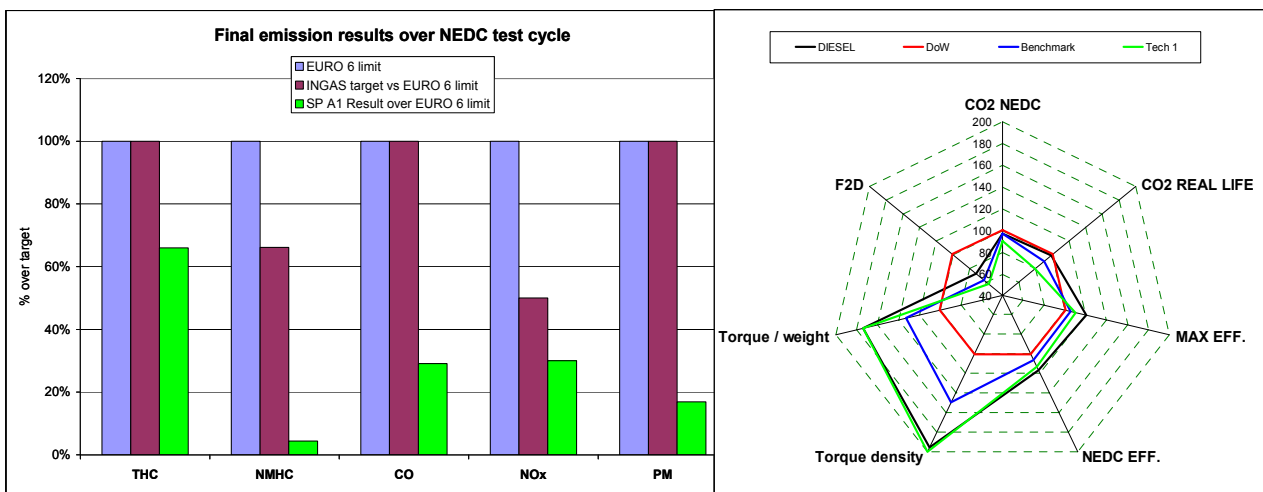

Fig. A1.6: SP A1 (Tech 1) emissions & performance

Each target has been fully achieved, in particular NG has confirmed the huge potential in reducing NMHC and PM emissions while the low NOx emission level is mostly related to the stoichiometric combustion approach that is in measure to ensure an efficient NOx reduction through the dedicated 3-ways catalyst technology.

Concerning the CO<sub>2</sub> figure (126 g/km CO<sub>2</sub> have been obtained over the NEDC), in the same Figure A1.6 it is possible to observe that a 10% reduction has been obtained with regards to the best existing engine configuration (throttled turbocharged), mainly due to the variable valve actuation system effective to reduce pumping losses at part loads and the right matching with the vehicle transmission. Other objectives in terms of vehicle fun-to-drive and performance have been fulfilled

as well. Finally the combination of the vehicle storage system and the fuel economy ensures an overall driving range by 520 km under a maximum pressure storage of 250 bar.

## Sub Project A2 – Turbo DI CNG engine

### INGAS Turbo DI engine concept

During the concept phase a downsizing concept with high boost turbocharging and a compression ratio of 12:1 was chosen due to the high knock resistance of natural gas. A displacement of 1.8 liter was chosen as a good compromise between downsizing benefit and driving behavior for the D-segment target vehicle. Base engine was the Daimler M271 engine with several modifications done by DAIMLER for the innovative combustion concept. Because of the advantages regarding packaging and mixture formation it was decided to choose a cylinder head configuration with centrally mounted direct injection. The boundary conditions lead to the configuration shown in Figure A2.1 to enable the operation strategies including charge stratification capability. Furthermore the engine is equipped with features like camshaft phasing, and an exhaust manifold with Turbocharger for 1050°C.

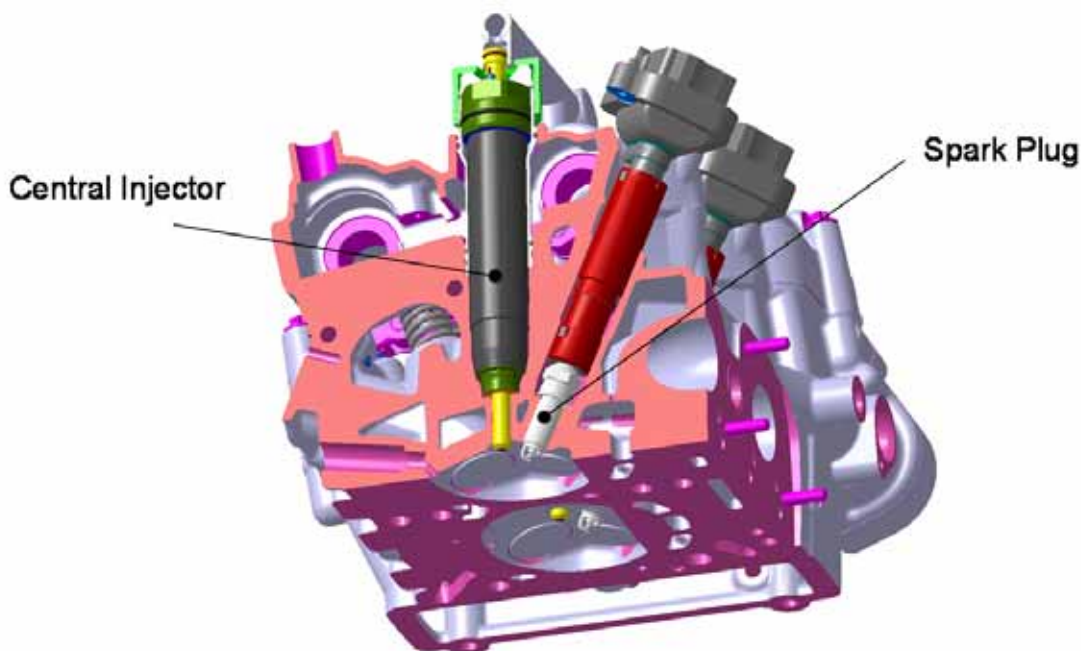

Figure A2.1: Cylinder head concept with central direct injection

### CNG Direct injection system

For direct injection of natural gas a major question deals with the injection pressure. For late injection during the compression stroke a relatively high fuel pressure is desirable. However, the useful filling capacity and the cruising range leads to a compromise. A maximum injection pressure of 20 bar was chosen as development target for the INGAS DI injection system. The DI injector itself is the key-component of the CNG DI engine and is based on a Piezo actuated outwardly opening nozzle including a stroke amplifier unit and was developed by SIEMENS.

- Due to the more stable behavior under different conditions and over runtime a drive mechanism with double-stack Piezo represents the final solution.

- The needle design was developed for better reliability and lower friction with special coating. The design of the hollow needle was assisted by 3D-CFD simulation of the in-injector flow to find the best number of holes and geometry for a maximum mass-flow, done by POLITECNICO DI TORINO.
- The stroke amplifier emerged as the most critical part in the injector. A sealed metal bellow design filled with silicon oil finally led to the necessary reliability in the 4<sup>th</sup> injector generation.

Regarding the development targets with the final solution the following results were reached:

- A needle lift of 300µm was reached leading to approximately 10mg/ms static flow, as recommended in the injector guidelines for the target power output of the engine
- The maximum allowed system pressure is 26bar
- Latest generation of injectors showed more than 30 million cycles of operation
- Regarding injector size there is some optimization potential. Latest generation had a maximum diameter of 28mm at 8.3mm at injector tip, and due to the double-stack design an overall length of 200mm.

Figure A2.2 shows the INGAS Gen 4 CNG-DI injector including the key-components lift-transformer and nozzle-needle.



Figure A2.2: INGAS CNG-DI injector with sub-components

### ECU & Subsystems

A prototype ECU with an I/O interface box was developed by CONTINENTAL AG to fulfill the requirements and flexibility needed for the CNG DI prototype engine. Different control units had to be connected. The power stages for the Piezo injectors and the ePCD were implemented and the communication via CAN-Bus between the ECUs and the vehicle related components was

established. A lot of CNG and especially DI specific functionalities were implemented in the software for the INGAS engine. The cylinder individual calibration of the injector characteristics was for example an important step to make the engine EURO 6 emission limit capable.

One of the very new components installed in the INGAS vehicle as well as on the test bed is the ePCD (electronic pressure control device). It allows adjusting the injection pressure variable over speed and load. The ePCD, developed by SIEMENS, is a device actuated by a series production Piezo stack and allows significantly improved dynamic behavior.

### **Combustion system development**

The basis for the engine behavior, efficiency and combustion stability was set in the layout of combustion chamber, intake ports, piston shape and injector. The validation and characterization was done in stationary investigation on the engine test bed at AVL. The main development fields are:

- Full load performance testing
- Part load optimization (for best engine efficiency)
- Development of strategies for catalyst heating and catalyst keeping warm.

The full load performance of the INGAS 1.8l CNG DI Turbo engine shows significant advantage for CNG direct injection, especially at low engine-speed the low-end torque target (290Nm at 1800rpm) was more than reached. 300Nm are already reached at 1500rpm, rated power output of 126kW was demonstrated. Compared to state-of-the-art port injected CNG engine the low-end torque was remarkably improved - e.g. the same engine operated as MPI reaches the 300Nm around 2500rpm. This behavior is reached by utilization of scavenging strategies like in modern gasoline DI Turbo engines and allows as a consequence implementing down-speeding and/or down-sizing concepts with significant benefit regarding fuel consumption.

In part load the main focus was put on fuel consumption respectively CO<sub>2</sub> emissions. The result of the base calibration map shows together with driving cycle simulations the potential to fulfill the INGAS CO<sub>2</sub> emission target. Especially when state-of-the-art measures like "Start-Stop" and "Intelligent generator control" are introduced, CO<sub>2</sub> emission values below 140g/km close to 130g/km are possible in this D-segment Mercedes E-class vehicle. In base calibration the results from the combustion development were transferred to the calibration of the engine ECU.

An application of lean stratified part load operation was tested but does not show enough CO<sub>2</sub> reduction potential to compensate the effort for exhaust gas after treatment. Furthermore there is not yet an after treatment system available for Methane emissions that shows sufficient conversion efficiency at the very low exhaust gas temperatures.

For catalyst heating different operation strategies were developed and tested. Finally the homogeneous mode with retarded ignition showed the best potential at lowest calibration risk for fast catalyst light-off.

An unconventional new approach for catalyst heating was investigated using post injection to increase the exhaust gas temperature. The strategy worked well at single cylinder level but showed critical stability behavior at multi cylinder engine, so that an application was not done. Furthermore HC was identified as the most critical exhaust gas component, for which the post-injection strategy did not point out any benefit.

Cylinder unbalancing is a strategy developed to provide energy to the catalyst. Differently from ignition retardation the energy is mainly transported chemically in form of increased CO emission in the exhaust gas to the catalyst brick. This method has proven to be most efficient, especially for keeping the catalyst warm in low load phases, therefore it was applied for the driving cycle testing.



### Mixing process with direct CNG injection - Transparent engine & CFD Simulation

As support to the combustion development mixture formation investigations on a transparent single cylinder engine were done at AVL in parallel to the multi-cylinder engine investigations on the stationary test bed.

The relevant operation conditions and injection strategies were investigated. Interactions between injection and air charge motion were evaluated. Statistical and advanced evaluation methods gave a deeper understanding for the mixture formation process using advanced gas direct injection. The visualization of the mixture formation was done by LIF (Laser induced fluorescence) with TMA (Tri Methyl Amine) traced fuel (Methane). Figure A2.3 shows example images of the injection jet in the combustion chamber demonstrating the high dynamics of the supersonic gas jet.

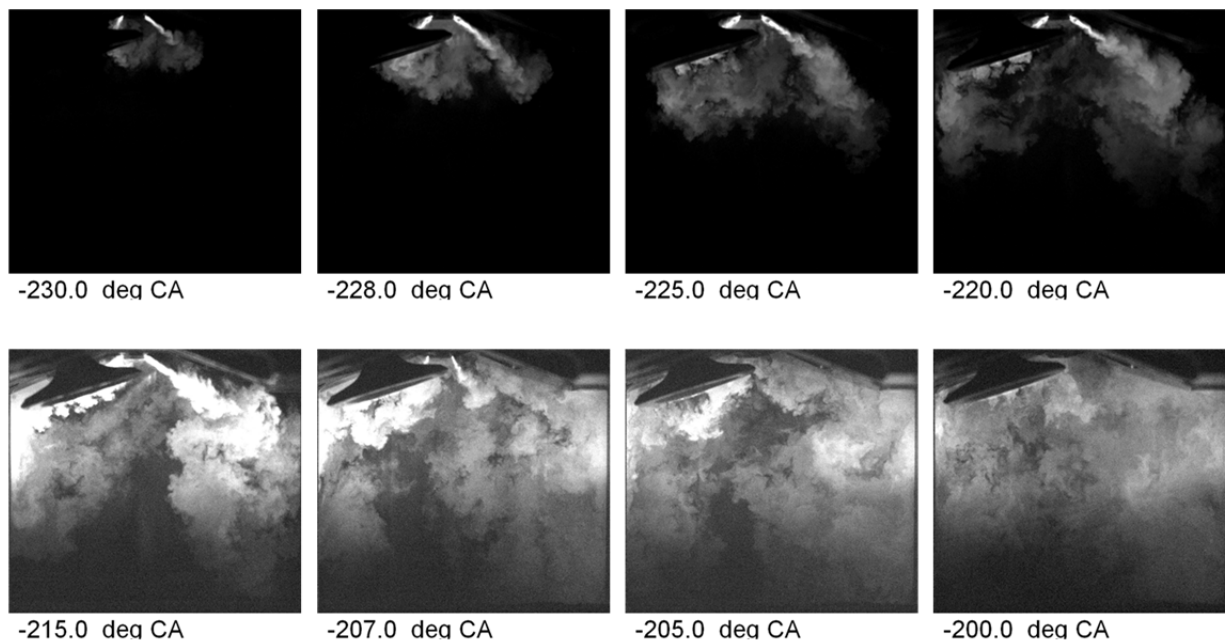

Figure A2.3: Example of injection jet visualization on the transparent engine

The main results can be summarized as follows:

- the time for mixing of gaseous fuel in the combustion chamber is significantly shorter than the necessary mixture preparation time of liquid fuel like in a gasoline DI system. Nevertheless this mixing process is influenced by the air charge motion and takes some time for good homogenization
- a high sensitivity and interaction of the injection-jet and near combustion chamber walls was detected and is caused by the so called “Coanda effect”.
- the potential regarding charge stratification was demonstrated
- new catalyst heating strategies for DI gas injection were developed.

In parallel a comprehensive CFD analysis of the mixture formation process in the INGAS DI-CNG engine was performed by POLITECNICO DI TORINO. The synergy between the optical investigation on the transparent single cylinder engine and the simulation activity allowed a deeper understanding of the mixture formation process, and supported the experimental investigation of the combustion process. In particular, useful guidelines for the optimal injection timing, as well as for the injector protrusion, were derived from the analysis of the optical and the CFD results.

In general, the best results were obtained for high injection protrusion. For homogeneous operation at partial load, the best results are obtained with very early injection in the suction stroke, whereas in the case of stratified mode late injection in the compression stroke allows the formation of a compact fuel cloud which can be ignited near TDC. Under full-load conditions, at low engine speed, end of injection has to be latest in the first 3<sup>rd</sup> of the compression stroke to reach a good homogenization.

### **Transient engine operation**

The pure numbers for stationary measured torque and power output were already mentioned. In stationary conditions so traction force of the INGAS vehicle exceeds the one of comparable CNG and even Diesel reference vehicles and is on the level of an E 220 CDI.

Especially for Turbo engines the transient response respectively the torque-build-up is even more important for real driving performance and fun-to-drive. Dedicated tests have been performed on the dynamic test bed at AVL to evaluate, analyze and improve this transient response. Similar to gasoline direct injection, the application of scavenging gas exchange is possible with Turbo engines with direct gas injection. In addition the direct injection itself offers new flexibilities by the variation of timing. In consequence time for torque-build-up was reduced to less than one half by optimized transient functionalities. Compared to a conventional MPI gas engine torque build shows equal acceleration potential even at 25 % lower engine speed. This transient power output benefit can – at least partly – be used to reduce fuel consumption by applying a “down speeding” strategy, where the engine is operated in a load / speed range of better efficiency. In the actual case a down-speeding ratio of about 15% (e.g. rear axle ratio from approximately 3.5 to 3.0) was applied. The torque benefit is even higher, so that an improved acceleration and fun-to-drive was reached. In real driving this low-end-torque improvement will “invite” the driver to use a higher gear which has a significant “real life” fuel consumption benefit.

At the fully dynamic test bed the engine calibration was optimized to follow especially the highly dynamic phases of engine start, accelerations and gear shifting during the test driving cycles. A calibration status was reached that enables reproducible testing at EURO 6 emission level.

Besides emission tests in NEDC also an optimization of the engine behavior under more realistic and more dynamic conditions by a “real driving cycle” proposed by CRF was done.

### **Vehicle performance**

The focus of the work on the demonstrator vehicle mainly by CONTINENTAL was to transfer the described potentials of the engine concept onto the road and to show its “fun to drive” in reality. Finally the INGAS demonstrator vehicle, see Figure A2.4, has shown its good drivability and fun-to-drive - at the final project meeting the improved acceleration potential with CNG-DI-Turbo was feel-able. Vehicle acceleration from 0 ... 100 km/h close to 10 seconds was measured – a pretty good result considering the weight of more than 2 tons of the demo car, increased by additional measurement equipment, second backup lead battery etc.

On the emission development side highest effort had to be spent to the emissions of Hydrocarbons due to the very stable Methane molecules that makes a catalytic conversion difficult. High compression ratio and better engine efficiency lead to significantly lower exhaust gas temperature compared to state-of-the-art CNG engines. Dedicated engine measures like aggressive catalyst heating and cylinder unbalancing combined with new specific Methane catalyst formulation from SPB2 make it possible to reach EU6 limits in stoichiometric operation. There is no risk regarding particulate emissions when using direct gas injection - the measured results show values far below future limitations.

Depending on the vehicle configuration (mainly gear box set-up) very low values of CO<sub>2</sub>-emission down to almost 130g/km can be reached – despite the relatively high driving resistance of the D-

segment demo vehicle. The demonstrator vehicle shows measured CO<sub>2</sub> values very close to the INGAS target of 140g/km. So the INGAS CNG-DI-Turbo engine enables to reach the INGAS target corresponding to a fuel consumption of 5.2kg/100km CNG combined with very good driving performance (acceleration, elasticity) and fun-to-drive. The demonstrator vehicle demonstrates this benefit in an impressive way “feel-able”.



Figure A2.4: INGAS demonstrator vehicle

## Sub Project A3 – Boosted lean burn gas engine

### Engine Development

The technology approach within the INGAS subproject A3 considers a natural gas engine using port fuel injection and homogeneous lean combustion. The target values regarding power and torque output require a high boost pressure level to realize high the BMEP in combination with considerable air excess for lean combustion.

In comparison to Diesel engine operation a 20% reduction of GWI (*Global Warming Impact*) is targeted what implies at least comparable efficiency level.

Concerning emission performance EURO VI level – for NO<sub>x</sub> ½ EURO VI - is anticipated. As a consequence a capable exhaust gas aftertreatment system regarding oxidation of methane as well as NO<sub>x</sub> reduction device has to be designed within SP A3.

The engine related technology strategy based on a Diesel engine which is converted to natural gas operation according to Otto-Cycle. However, typical gasoline engines do not cover the required peak pressure level of more than 150 bars. Thus the engine Z19DTH (V<sub>H</sub> = 1.9 l, Diesel) was chosen and modified within this project. This means in detail:

- Application of natural gas capable compression ratio using the FEV-ATAC® combustion system (*ATAC* ⇔ *Advanced Turbulence Assisted Combustion*)
- Modification of intake ports towards high swirl level to generate high turbulence intensity to improve the combustion characteristics
- Application of a spark plug into the cylinder head and installation of an ignition system
- Design and built up of the intake manifold system with integrated fuel metering hardware

- Setup of an engine management system
- Layout of a 2-stage boosting system dictated by the power/torque target. Elaboration of the corresponding packaging due to increased space requirement compared to single stage boosting

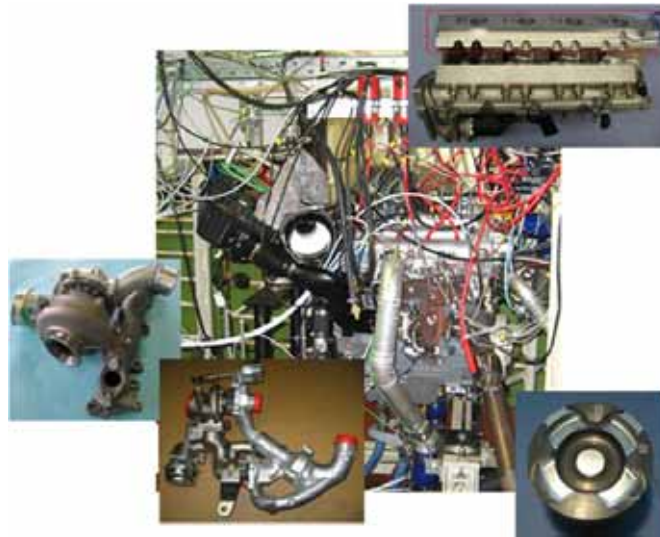

Figure SPA3-1: Lean burn gas engine (center) and developed components (cylinder head, piston, boosting system)

Due to high complexity of influencing operation parameters – ignition timing, air/fuel ratio and fuel metering timing with strong impact on operation behavior – efficient map generation has been performed supported by statistical methods (DoE – Design of Experiment).

The influence of the natural gas injection timing on combustion behavior was analyzed using CFD simulation. In detail the mixture preparation and the combustion have been investigated. These results match well with the experimental data.

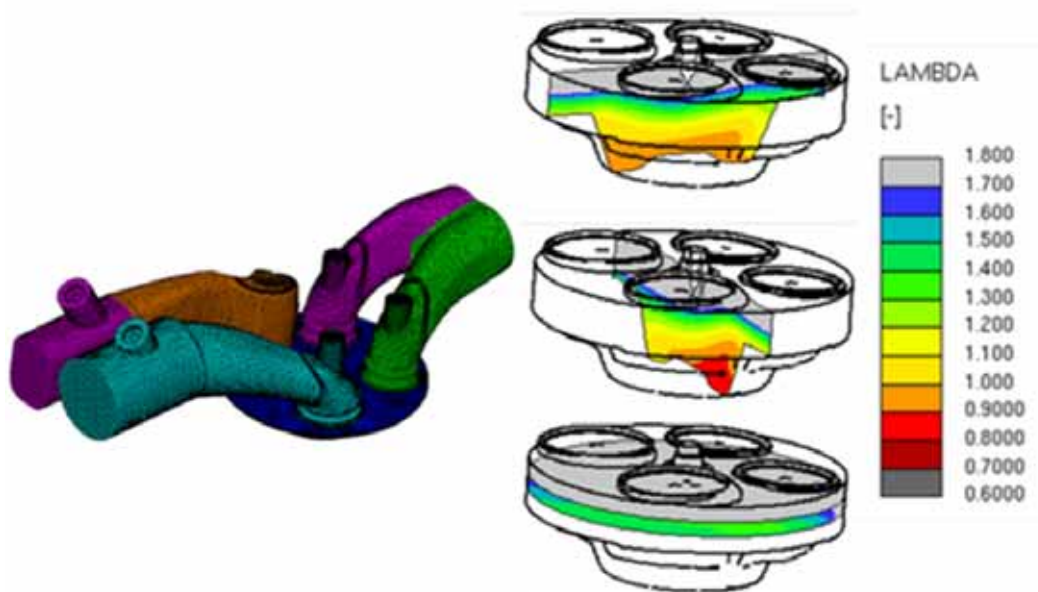

Figure SPA3-2: CFD Simulation of mixture homogenization

The lean burn capability of the combustion system enables significant fuel saving in the range of 10% up to 15% compared to stoichiometric operation. The required relative air/fuel ratio range is

from 1.4 to 1.6. Engine out NO<sub>x</sub> concentration is reduced by approx. 85%. However, high air excess results in unacceptable HC emission levels. The exhaust gas temperature will drop at the same time. This has to be considered when developing the exhaust gas aftertreatment concept. Reduction of the initial tested compression ratio (CR) of 13 units down to 12 units enables on the one hand a noticeable increase of the exhaust gas temperature (EGT) and simultaneously improved raw emission behavior while the efficiency is equal or deteriorated in an acceptable range. Therefore the lower CR represents the final value.

Achievement of power/torque equivalent to the diesel counterpart (120 kW/320 Nm) requires 2-stage turbo charging if fuel efficient air excess (rel. A/F > 1.4) is aspired.

The engine with a displacement of V<sub>H</sub>=1.9 l shows with the load profile of the referred vehicle OPEL ZAFIRA a low exhaust gas temperature level. At the same time HC and NO<sub>x</sub> raw emissions gives a need for very high conversion efficiency of the catalysts. In addition it was seen that the targets for fuel consumption with this configuration are hard to reach. It has been concluded to perform the investigation of the vehicle behavior using an engine with a displacement of V<sub>H</sub> = 1.6 l.

Due to change in consortium no vehicle was built up and tested in target configuration. A detailed simulation of the vehicle performance in fuel consumption and emission behavior was done.

It was setup a detailed model to simulate the engine behavior regarding fuel consumption and emission performance within a vehicle. The engine performance is considered by implementing the essential engine maps that contain the base operation parameters (i.e. relative air/fuel ratio) as well as the relevant maps for emission behavior, fuel consumption and pressure and temperature values. The maps are based on the experimental results of the V<sub>H</sub> = 1.9 l engine and were scaled to match the smaller engine (V<sub>H</sub> = 1.6 l) with high accuracy.

A final calibration was elaborated using lean combustion from start of the NEDC in combination with an improved heating strategy. This means the combination of ignition timing and injection timing was optimized with the focus on realizing lowest raw emissions and highest EGT. The simulation results show figures close to the target values:

	<b>Target</b> g/km	<b>Result</b> g/km
<b>CO<sub>2</sub></b>	124	127
<b>THC</b>	0.10	0.18
<b>NO<sub>x</sub></b>	0.030	0.043

Table SPA3-1: Simulation Results

### **Exhaust Gas Aftertreatment System Development**

The development of the exhaust system for an ultra lean-burn CNG engine that fulfill Euro 6 standard is a challenging task as emission data from the previous lean-burn NICE project indicated required approximate conversions of 97% of CH<sub>4</sub> and 88% of NO<sub>x</sub>. As the lean burn exhaust contains a high oxygen concentration (5-8%) none of all known 3 way catalyst formulations used for stoichiometric gas engines could be used in this project. Therefore we could from the start foresee two main catalyst development challenges in the project:

1. Catalytic oxidation of methane to carbon dioxide and water at the available engine exhaust temperature and under ultra-lean conditions.

The most efficient CH<sub>4</sub> oxidation catalysts is Pd supported on high surface area carriers with a light-off temperature for methane (T<sub>50</sub>) around 300 °C. Water vapour in the exhaust gas shifts the light-off temperature up to approx.. 425 °C. This severe requirement to the exhaust temperature implies that the CH<sub>4</sub> oxidation catalyst must as first priority be placed very near the engine manifold. High activity catalyst samples composed of Pd supported on high surface area carriers were delivered by HT to the SAPT for car test under the designation as a 1st generation catalyst. Due to space limitations in the Opel ZAFIRA the oxidation catalyst was divided into a 1 liter close coupled and a 2 liter underfloor catalyst.

However, in general these very active Pd based lean burn oxidation catalysts are extremely sensitive to sulfur deactivation (i.e. poisoning of the active catalytic sites by SO<sub>2</sub> and SO<sub>3</sub>) even at ppb levels of sulfur in the exhaust. Potential supply of complete sulfur-free natural gas qualities was discussed with the INGAS gas supply partners but it showed up not to be feasible. This sulfur poisoning problem was addressed both at CHALMERS and HT.

At CHALMERS, a study with the aim to gain more knowledge about the active state of Pd and Pt for CH<sub>4</sub> oxidation was performed. Different sample configurations were compared to investigate the influence of Pt-Pd interaction on the activity for CH<sub>4</sub> oxidation and sulfur sensitivity. Pd shows an initially higher activity than Pt. When the samples are exposed to SO<sub>2</sub>, the Pd system gradually loses activity. However, the Pt system does not degrade as rapidly as the Pd system. There is initially a promoting effect on the activity when SO<sub>2</sub> is introduced. However, the observed promoting effect diminish as a function of time on stream and instead the CH<sub>4</sub> oxidation becomes inhibited.

Ceria itself is active for total CH<sub>4</sub> oxidation above 450°C, likely due to the oxygen dynamics in the ceria system. However, the CH<sub>4</sub> conversion decreases upon SO<sub>2</sub> introduction and is not regained when SO<sub>2</sub> is removed from the feed. These results indicate that SO<sub>2</sub> does not form new active sites on the support material itself. Sulfates are formed on ceria immediately upon SO<sub>2</sub> introduction and that the sulfate formation is accompanied by a corresponding instantaneous increase in CH<sub>4</sub> conversion. Further, close interaction between Pt and ceria is important for the promoting effect to occur. Since CH<sub>4</sub> oxidation is self-poisoned by oxygen over Pt catalysts, i.e. CH<sub>4</sub> dissociation is the rate limiting step, exposing the catalyst to sulfur most likely create and/or expose sites for CH<sub>4</sub> dissociation. Sulfate formation on ceria sites close to Pt can modify the Pt sites and/or form new sites in the metal-support interface which can polarize the C-H bond and thus facilitate CH<sub>4</sub> dissociation.

Despite the lean conditions, upon SO<sub>2</sub> exposure, the ceria is reduced indicating that oxidation of ceria with gas phase oxygen is kinetically hindered. Dissociative O<sub>2</sub> adsorption on Pt, however, can facilitate ceria oxidation via oxygen spill-over. This process will likely decrease the oxygen coverage and/or induce rearrangement of adsorbents on the Pt surface and, thereby, facilitating the dissociative CH<sub>4</sub> adsorption and subsequent oxidation. Eventually the ceria becomes saturated with sulfates and the oxygen mobility in the system decreases which may explain the inhibiting effect. The results from this study indicate that it is not possible to permanently increase the activity for methane oxidation over Pt/ceria catalysts by sulfur addition. However, it is conceivable that periodic regeneration in analogy with regeneration of NO<sub>x</sub> traps can be utilized also for these catalysts.

HT developed after heavy screening a much more sulfur tolerant CH<sub>4</sub> oxidation catalysts based on a more expensive precious metal formulation, called 2<sup>nd</sup> generation catalyst and this had nearly the same activity as the above described 1<sup>st</sup> generation. Samples of 2<sup>nd</sup> generation was also produced and delivered to SAPT for NEDC tests on the Opel ZAFIRA.

## 2. Removal of nitrogen oxides at lean conditions (5-8% oxygen)

Two potential solutions for NO<sub>x</sub> removal were investigated at the start: Lean NO<sub>x</sub> trap technology and selective catalytic reduction (SCR). The Lean NO<sub>x</sub> trap solution was early abandoned due to problems with trap regeneration with CH<sub>4</sub>, limited NO<sub>2</sub> formation from the CH<sub>4</sub> oxidation catalyst, limited temperature window and, not least important, high fuel penalty from the lean/rich management.

However, the development at HT of high-active zeolite based SCR catalysts seemed to be able to meet the required NO<sub>x</sub> conversion in underfloor position using only the (slow) normal SCR reaction scheme as the NO<sub>2</sub> formation over the CH<sub>4</sub> oxidation catalyst is very limited. SCR catalysts use NH<sub>3</sub> as reducing agent, normally generated from decomposition of urea into urea-water solutions. But in this case a commercial system with NH<sub>3</sub> absorbed in a salt instead of urea-water solutions has been selected as ammonia source; NH<sub>3</sub> can be directly injected from low temperatures (170 °C) and the mixing distance can be short and the exhaust temperature will not decrease by water evaporation, selecting the former ammonia source. The SCR catalyst volume was optimised to 4 l considering required NO<sub>x</sub> 90% conversion, the low temperature and the thermal mass of canned catalysts in underfloor position

A number of the above described SCR catalysts were delivered as washcoated cordierite monoliths for exhaust system assembly at SAPT. The system consisted of close coupled and underfloor CH<sub>4</sub> oxidation catalysts, ammonia injection, underfloor SCR catalyst, and NO<sub>x</sub> sensors. The NEDC chassis dynamometer testing at a 1.6 l CNG Opel ZAFIRA car in emission was performed with conversion of the 1.6 l CNG engine into lean mode targeting rel. A/F ≈ 1.4

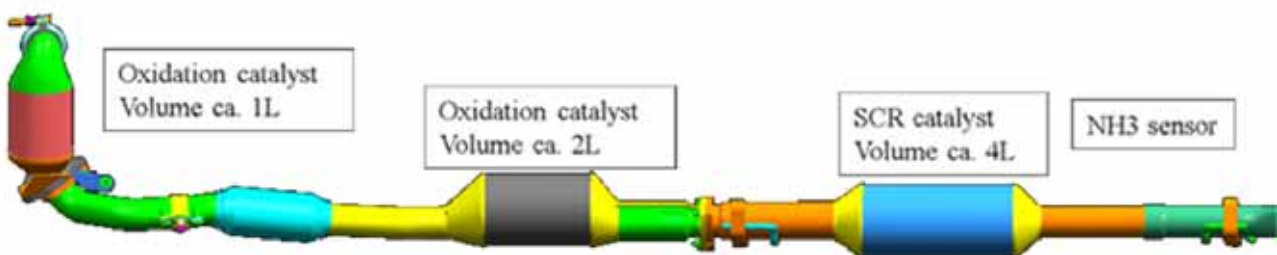

Figure SPA3-3: InGas Exhaust gas aftertreatment system for lean combustion

The NEDC test results showed that it is possible to reach the CH<sub>4</sub> (THC) EURO 6 emission level with the developed exhaust gas aftertreatment system if the following items are addressed at the same time:

- Short light-off time implying engine management for warmer exhaust gas
- Thermal management during operation that hinders drop below light-off temperature
- Overall low engine out methane levels

The 1<sup>st</sup> generation CH<sub>4</sub> oxidation catalyst met the Euro 6 limit 0.1 g/km HC while the 2<sup>nd</sup> generation was just above the limit. CO is easily removed.

The NEDC results for NO<sub>x</sub> removal by the developed SCR catalyst with an injection of gaseous NH<sub>3</sub> to the exhaust gas showed that the EURO 6 NO<sub>x</sub> emission target 0.06 g/km also could be met even 160 s elapsed before the SCR catalyst was active in underfloor position. The following points should be kept in mind:

- Low engine out NO<sub>x</sub> levels are desirable during engine start as the underfloor SCR converter needs at least 170 °C to operate and thermal inertia of the system
- Low engine out NO<sub>x</sub> levels during high engine load. The mass flow of nitrogen oxides can however be relatively high.

The above described NEDC tests are of preliminary nature. Long time sulfur poisoning is an important issue for all CH<sub>4</sub> oxidation catalysts.

Due to a change in consortium final tests on vehicle have not been performed.

## **Sub Project B0 - Fuels for advanced CNG engines**

### **Impact of fuel properties on engine behavior**

Subproject B0 covered the fuels-related aspects of the development of advanced CNG-vehicles, in order to achieve maximum fuel flexibility of advanced engines operated with methane-based gaseous fuels. The current future supply situation in Europe is characterized by an increased share of LNG (liquid natural gas) and of Biomethane as supply sources. A survey determining the bandwidth of the properties of the different natural gases, including the option of adding hydrogen from renewable sources to natural gas, led to the identification of five limit gases (L1 to L5) relevant for engine development. L1 gas is a gas with a low calorific value that could be encountered in countries like France, Germany, Romania, Hungary or Poland. L2 is a typical natural gas, L3 too, but with a low Methane Number which could lead to knock problems. L4 and L5 gases contain 20% of hydrogen mixed with a standard natural gas (L4) and with a low Calorific Value gas (L5).

The impact of the range of relevant fuels on engine operation was investigated by engine testing at the Czech Technical University in Prague – Josef Bozek Research Centre (CVUT JRBC) and by numerical simulations carried out by GDF SUEZ and CVUT JRBC. Limit gases were first tested on test facilities at JRBC. First those tests allowed both CVUT JBRC and GDF SUEZ to calibrate constants of their own computational simulation tools with the purpose to obtain a good agreement between simulated returns and test bench results.

In the framework of investigation of fuel quality impact on engine parameters the computational procedures were compiled which describe the engine response on fuel composition variations. The procedures were calibrated and verified using experimental data acquired within wide range of operational regimes and fuel blends. The calculation routines are universally valid and can be implemented into various simulation tools as sub-models. They enable to predict the heat release pattern as well as knock occurrence when engine is fuelled by natural gas of various origins and with blends of natural gas with hydrogen. By combination of experimental and simulation approaches the impacts of fuel composition on engine power, efficiency and emissions were determined quantitatively. Guidelines were derived for exploitation of advanced engine control possibilities to compensate possibly negative impact of fuel composition on engine power and efficiency with respect to applicable constraints.

In the most generalized manner it can be claimed that satisfactory level of fuel flexibility can be obtained within whole range of operational conditions of small (car dedicated) highly turbocharged engine providing that appropriate adaptation of engine adjustment is applied. This statement is valid within fuel quality tolerance bandwidth as it was declared by gas grid operators. The adoption



of knock-suppressing control interventions is typically the most stressing demand for adaptation of engine adjustment according to fuel composition. The most important fuel property is its knock resistance.

In the last period of the simulation activities, the models were then applied on the engine developed by CRF in subproject A1 to determine the performance of engine over the limit gases defined in the INGAS project and an extended matrix of European gases. Engine performance, based on the Indicated Mean Effective Pressure (IMEP), has been investigated by GDF SUEZ with the GNVSim model in the AMESIM platform. Based on IMEP comparison, simulations were used to compare engine performance obtained with G20 (99% CH<sub>4</sub>) to IMEP obtained with other gases. All low calorific value gases have a high negative impact on engine performances. For example, with limit gas L1 (with 19.2% of N<sub>2</sub>), the IMEP decreases by 35% compared to G20. L gases are mainly available eastern countries like Hungary, Romania, Poland, but also France and Germany which still have a L gas network. Apart from L gases and some low calorific value H gases, performances of the SPA1 engine are quite constant over all European gases (IMEP(natural gas)/IMEP(G20)>0.95).

In the future, Hythane (blends of methane and hydrogen) gases, corresponding to INGAS limit gases L4 and L5 could help increase performances of natural gas vehicles (as IMEP(Hythane)/IMEP(G20) is of order 1.1) and reduce CO<sub>2</sub> emissions. Hydrogen admixture reduces the methane number. Numerical simulation have shown the occurrence of knock on an extended zone of operational conditions. A specific development or engine tuning for these gases may be required. GT-Power engine model submitted by CRF was completed by JBRC, heat release and knock prediction sub-models and predictive simulations were performed. Knock-free operation was confirmed even at high BMEP operation of the CRF engine fuelled by pure methane without EGR (Exhaust Gas Recirculation device). Light knock was predicted by CRF engine operation at high load when fuelled by limit gasses with low methane numbers and with Hythane. No drawbacks were predicted regarding engine power and efficiency when engine operates with any of limit gasses assuming that ignition timing and boost pressure is optimized for each fuel.

## **Gas sensors**

The current control concepts rely on signals from the engine management system and from the lambda sensor. An information about the gas quality in the gas rail for use in a fast forward open loop control is as yet not available. Therefore, a novel low-cost gas quality sensing technique has been investigated by company MEMS during the INGAS project. In the first phase of this project feasibility was proven and a technology demonstrator was realized. In the second phase, the demonstrator was tested under road conditions within different cars and also by CRF.

First, sensor reliability was tested within a VW Caddy of a Swiss gas supplier company situated in Basel. The car was refueled only in the nearby area, so no major gas quality changes were expected and finally detected correspondingly. With a standard deviation for calorific value of only 0.6% and for methane number of 1 in absolute terms, low statistical spreading was demonstrated for the sensor system. Furthermore, a long term test was conducted with a VW Passat by MEMS AG. Fuel stations of a greater area could be covered, mainly stations in Germany, Switzerland and Italy. The seasonal and local differences in gas quality were clearly detected observing significant changes of the methane number ranging from 70 to 100 MN.

The second sensor prototype was first installed onto an engine test bench at CRF, where it was checked with different, predefined gas mixtures. After this it was installed within the INGAS

demonstrator vehicle, a Fiat Bravo. CRF tests proved the functionality of the sensor under different circumstances.

Since methane number is the most relevant figure for CRF, a more basic sensor design, characterized by an easy in-rail mounting without gas outlet, can be used. Implementing this concept and considering previous test findings, a second demonstrator was built. The system is now capable to withstand high pressures, a prerequisite for an in-rail installation. Purpose of the sensor re-design was also cost reduction. With a much simpler mechanical construction, estimated costs between €90 and €130 for 1000 units are  $\frac{1}{3}$  lower than for the first prototype. Cost-benefit-considerations have to distinguish between nice and need to have reasons for a gas quality sensor. The former relate to comfort attributes like residual range indicators whereas above-mentioned emission restrictions may soon make the use of such a sensor a necessity.

### **Impact of oil content into Natural Gas**

A special aspect of fuel quality, namely the content of oil as particles or aerosols in CNG, was investigated by E.ON Ruhrgas. In recent years, there have been isolated cases reported in Germany of operating problems with CNG engines as a result of oil deposits in the gas system, above all on the gas valves. Normally, it is compressor oil residues from CNG fuelling stations which are found in the gas systems of vehicles and can cause problems. For this reason, the German CNG automotive fuel standard DIN 51624 provides for a limit value for oil and particular matter (aerosol). However, this value has not yet been specified because the background knowledge for determining a quantitative value is not yet considered to be sufficient. Therefore, the INGAS project trials were to provide information on how great the tolerance of the vehicle gas system is to oil entrained in the gas. For this purpose, a test facility to examine the effect of oil was installed on the engine test rig of E.ON Ruhrgas in Essen.

In order to obtain sound conclusions on the tolerable content of entrained oil, a very high dosage was intentionally chosen, i.e. an oil content of 70 mg/m<sup>3</sup> or 87 mg/kg. This figure is much higher than the figures which have been measured in practice at a large number of gas fuelling stations in Germany. The studies have shown that even with the above-mentioned very high oil carryover in CNG in liquid form in three consecutive tests – each 200 engine hours - no significant quantities of oil remain in the gas supply. Most of the oil (roughly 90 %) is combusted in the engine. In the tests, only oil in its liquid state was found again. Solid or wax-like deposits were not formed on the relevant components (pressure regulator, piping and fuel injectors). Relevant quantities were detected, particularly in the gas rail and in the intake manifold. No oil was visible on the injectors themselves and on the gas pressure regulator. The synthetic oil and the mineral oil behaved virtually the same in the tests. Only marginal deposits were visible in the combustion chambers after completion of the tests due to the comparatively small oil loading.

Thus it was proved that the potential oil carryover from the compressor of the fuelling station causes no problems when the vehicle is in operation under normal operating conditions and given a compressor with still acceptable wear and in an acceptable maintenance condition. Given the results determined, it is proposed to limit the oil loading to a value which is above the normal oil carryover at a gas fuelling station but below the oil content chosen in the tests conducted. This limit value could be roughly 40 mg/kg.

## **Blends of methane and hydrogen**

The fuel hythane (natural gas with essential amounts of H<sub>2</sub>, e.g. 20% H<sub>2</sub>) shows potential for modern compressed natural gas (CNG) vehicles due to its low-emission combustion in the motor, as mentioned before. However, the Regulation ECE R110 limits the hydrogen content in natural gas to 2 vol%, taking account to the risks of hydrogen embrittlement of the steel. In Europe, the material 34CrMo4 is employed exclusively. This material is in principle compatible with hydrogen and is also used in gas trailers, but with specified requirements which are not fulfilled by the CNG steel tanks in the market. Therefore the tanks in use are not suited for hydrogen contents of more than 2%. Further research is needed to understand the influence of hydrogen amounts of up to 20% on the embrittlement behavior of CNG steel tanks. A short-term or mid-term introduction of hythane is possible by launching dedicated hythane vehicles and by installing a separate hythane filling infrastructure.

## **SPB1 - Gas storage for passenger cars CNG engines**

### **CNG Storage System Requirements**

The main results of the comparative analysis undertaken by CRF, which focused on the CNG storage solutions used on vehicles which are currently available on the European market, was that the objectives of the project do represent a significant step forward with respect to identifying feasible solutions for advanced CNG storage system and its constituent components (i.e. cylinders, valves, and pressure regulator) to extend the driving range of economy class vehicles (B- and C-segment) in which the space available for a large capacity CNG storage systems is severely limited.

### **Development & validation of lightweight, low cost composite vessels**

In order to achieve an optimal design solution of advanced CNG thermoset vessel design based on a glass and carbon hybrid composite structure for the new lightweight, low-cost composite vessels, more than 50 design solutions were investigated by Xperion. A total of 125 cylinders of the Hybrid Vessels Gen 1.3 were produced, 50 of them for the extensive tests conducted at BAM and WRUT within the project. Through the various tests (Figure B1.1), it was possible to conclude that the most critical drop for the safety of the whole construction is drop in vertical position. In general the vessels have been optimized for weight rather robustness; nevertheless, by appropriately redesigning the area around the neck of the vessels, it was possible to respect all of the ECE R110 tests without the need to add a shock absorbing protector onto the domes of the cylinder.



Figure B1.1: Extensive testing was performed by BAM and WRUT of the new vessels.  
(Shown, clockwise from top left: Burst tests, fire engulfment, bullet penetration, and AE-testing)

The finally achieved design, the Hybrid Vessels Gen 1.3 solution, seems to be the best compromise between weight saving, economics and volume.

When the design had been finalised, and the ECE R110 tests respected, Xperion designed and manufactured two different vessel dimensions for integration within the FIAT Grande Punto Vehicle demonstrator, one with 21 and a larger vessel with 60.5l water capacity both of which used the INGAS Hybrid Vessels Gen 1.3 design (Figure B1.2).



Figure B1.2: The new lightweight, low-cost Hybrid-composite Vessels Gen 1.3 CNG vessels developed and realised by Xperion during the InGAS project

As regards mass production of the vessels, in an automotive high volume manufacturing process, the cycle time of a wet winding process (more than 30min for an automotive CNG vessel) is rather long in comparison to other regular manufacturing processes in the automotive industry. To overcome this hurdle, Xperion would recommend to split the production chain in several different production cells, which can be combined to high volume production line. In particular several production cells for wet winding can feed one cell of the oven for curing. By multiplying the production cells, a production volume up to 500.000 units per year would be possible within a reasonable investment and by applying well-known, robust production technologies. One main advantage of this high volume manufacturing concept is that several vessel dimensions can be produced in parallel. By introducing modularity into the vessel manufacturing process, a high redundancy can also be achieved in case of a breakdown of one production cell or for maintenance, while enabling a high volume flexibility in case of varying demands by customer. The study of quality aspects of advanced type IV pressure vessels conducted by BAM clearly demonstrated the potential of acoustic emission as the quality control method within the manufacturing process as a 100% non-destructive test. With the use of the reusable coupling, the sensors are easily and quickly applied on top of the pressure vessel surface. Further R&D efforts in future should aim to improve the determination of the relevant criteria in order to enable a more automated analysis of the AE test results and to improve detection of highly localised defects e.g., knots in the composite. Furthermore, for application within serial mass production, automated methods would be needed using AE-sensors with higher reliability and lower cost.

### **Advanced storage system components**

Ventrex developed a new generation of an electronic pressure regulator during the project focusing on the functional optimisation and the reduction of size (Figure B1.3). In parallel with the design work, many validation tests were performed in the laboratory and on a test vehicle. Finally, a FIAT Bravo demonstrator vehicle was realised in conjunction with INGAS SP A1 which used the VENTREX pressure regulator and control unit. By performing a series of functional tests on this vehicle, highly satisfactory performance was demonstrated by these components which met the specifications and achieved the project targets.

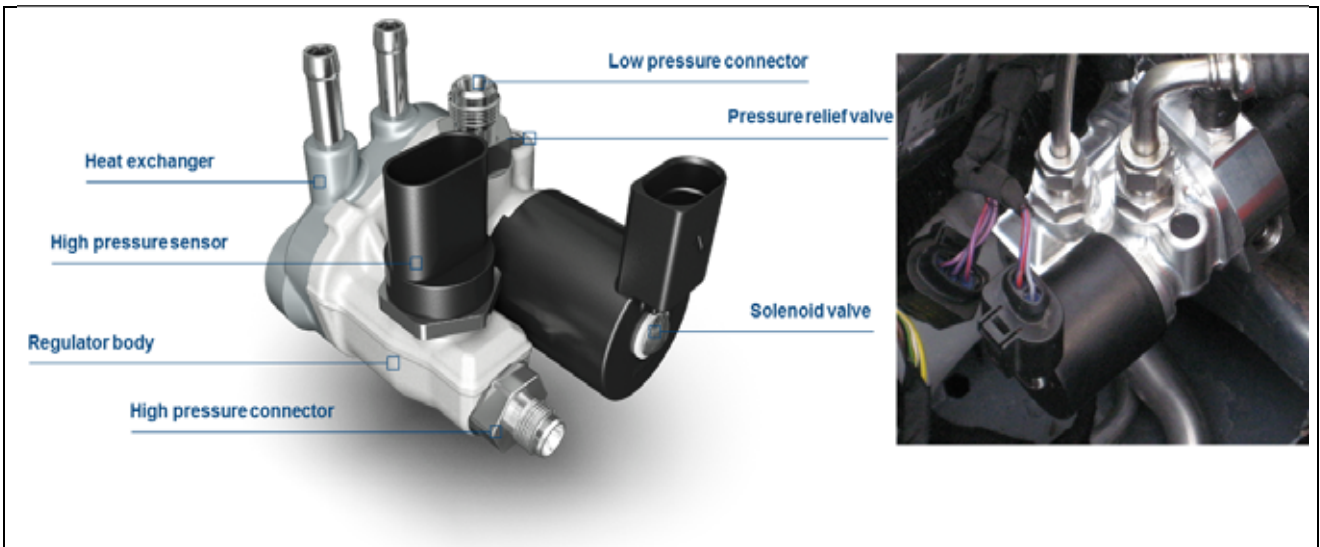

Figure B1.3: The electronic pressure regulator developed and realised by Ventrex during the InGAS project

Ventrex also developed an advanced in-tank shut-off valve, developing and testing a series of different concepts. Following the acquisition by Ventrex of the CNG High Pressure Business Division from Bosch, including the internal tank valve, the Bosch design was used as a basis for the further development enabling an ECE R110 conforming in-tank valve which can be screwed into the Xperion pressure vessel to be realised (Figure B1.4).



Figure B1.4: The advanced in-tank valve developed and realised by Ventrex during the InGAS project

Following the successful completion of a series of functional and misuse tests, a set of valves were supplied in order to realise the FIAT Bravo (SP A1) and FIAT Grande Punto (SP B1) prototype vehicles. By performing a series of functional tests on these vehicles, highly satisfactory performance was demonstrated by these components which met the specifications and achieved the project targets.

The engine control system can play a more important role in managing the different conditions that can occur on vehicle with regards to the control of performance and the detection of conditions that could induce safety and reliability concerns. During the project, a specific software strategy for control of the fuelling line was implemented by CRF which introduces cross-checking of the pressure levels in the high pressure and low pressure line. The comparison of these values at key-off and key-on conditions supports the control of potential internal and external leakage of gas from the system, thus increasing the robustness of the system with regards to safety issues.

### **Storage Module Concepts**

During the project, an innovative a CNG storage module for an economy-segment car (Fiat Grande Punto) was designed, validated using numerical simulation and realised physically by CRF which integrated the advanced CNG cylinders developed by Xperion, and a re-designed rear suspension system. This storage module (Figure B1.5) respects the technical specifications defined in the project, and in particular:

- Tank capacity of approx. 130 lt
- Minimal impact on the space within the passenger compartment and in particular no reduction in the habitability on the rear passengers
- Minimal reduction (-10%) of the space in the luggage compartment
- Minimised the variations of the vehicle settings so as to reduce to a minimum the impact of the vehicle performance characteristics, also with respect to overall efficiency
- Adequate aerodynamic performance

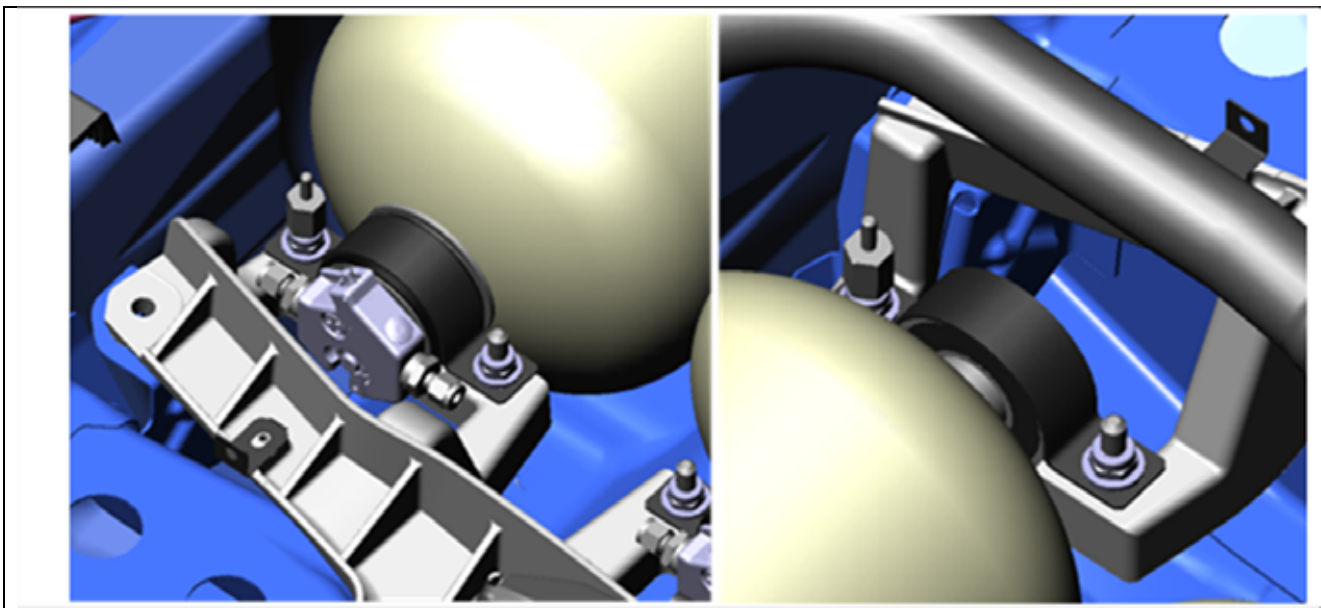

Figure B1.5: Details of the neck mounting system of the vessels in the advanced CNG storage module developed and realized by CRF during the InGAS project

As regards the redesign of the rear suspension for incorporation in the CNG storage module, the final solution offers a number of slight advantages with respect to the original configuration without

exhibiting significant variations in terms of ride-comfort and handling performance. Furthermore the assessment of the productive cycle required for the innovative CNG storage module system concluded that the concept can be made to be direct compatible with standard assembly process operations and material flow, assuming such issues are evaluated sufficiently early process design analysis. On this basis, the solution proposed offers adequate CNG capacity to achieve a driving range in the order of 500km with less additional weight when compared to other solutions while offering a good intrinsic safety and compatibility with automotive assembly process.

### **Advanced CNG Vehicle Concepts**

In order to be able to accommodate in the vehicle the advanced CNG storage module developed in the subproject, based on a modular archetype using Hybrid composite Type IV vessels attached to the vehicle via neck mounting, the under-body of the vehicles was completely re-designed in order to respect the following specifications:

- Develop of the under-body for the integration of the advanced CNG storage module
- Ensure a high-level of intrinsic safety of the advanced CNG vehicle
- Analyse of the assembly/disassembly of the storage unit vs. on-line assembly
- Minimise the weight
- Limit the required variations so as to reduce to a minimum the impact of the vehicle performance characteristics.

The successful realization of the advanced CNG storage module and its successful installation on the Fiat Grande Punto technology-validator vehicle (Figure B1.6) serves to validate the solution in terms of technical feasibility and technological viability, in direct accordance with the requirements of the project targets.

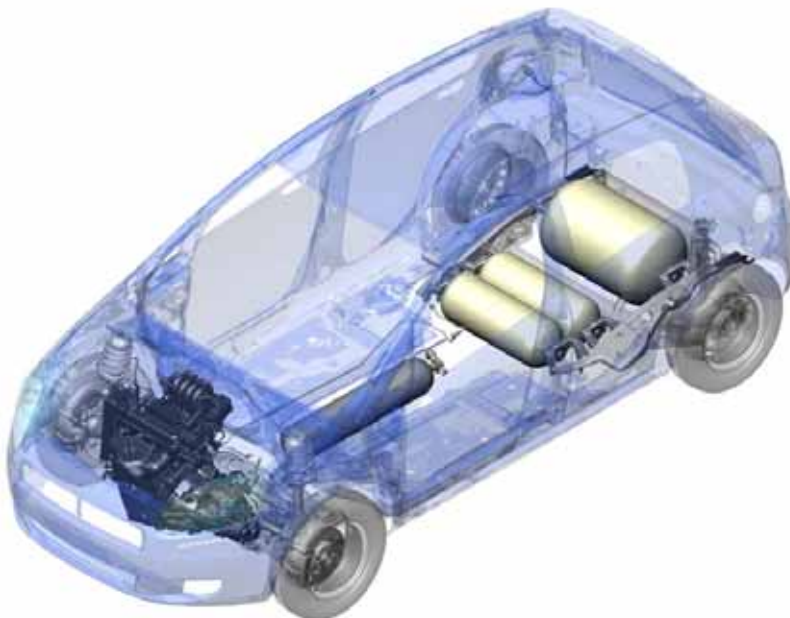

Figure B1.6 - Image of the advanced CNG storage module integrated into the FIAT Grande Punto vehicle developed and realized by CRF during the INGAS project



The virtual performance assessment which was conducted also validated the solution in terms of stiffness, crashworthiness and NVH performance:

- Using a detailed FE model, it was possible to verify that both the bending and torsional stiffness, and the first bending and torsional eigen-frequencies of the Body-in-White fulfilled the pre-defined specifications. Furthermore, by conducting static and dynamic simulations with and without the vessels, it was ascertained that the presence of the vessels does not influence to any significant extent the salient static and dynamic characteristics of the vehicle body due to the presence of bushings in the connection between the vessels and the vehicle.
- A detailed numerical analysis of the vehicle complete with the advanced storage system, which was further supported by an experimental analysis on the demonstrator vehicle, revealed that the dynamic behaviour of the vessels does not adversely influence the behaviour of the vehicle when excited by road-surface induced oscillations due to the filtering effect through the attachments of the vessels to the vehicle.
- The detailed analysis of the structural resistance of the storage module served to validate the selection of the aluminum alloy AlSi9MgMn as appropriate material for the frames of the CNG storage module. However the results of the analysis also indicated that, before finalizing such a design for mass production, further detailed optimization of the vessel supporting brackets may be appropriate to reinforce these potentially critical regions.
- The crashworthiness analysis served to validate the technical feasibility of the modular advanced CNG storage system. With respect to the European frontal, lateral and rear impact standards, the numerical simulations demonstrated that the level of forces acting on the storage module in general, and the vessels in particular, would not give rise to any specific issues in terms of structural integrity. Instead the more severe Japanese TRIAS33 rear impact test standard, which Fiat vehicles are conventionally designed to fulfilled, would give rise to relatively high levels of forces acting specifically on the larger, rear vessel due to the relatively confined deformation space in the original configuration. Correspondingly a series of design variations were identified and analyzed, including the re-positioning of the rear exhaust muffler in order to avoid any possible impact with the rear vessels, and a relatively small design variation in the rear floor section of the vehicle to avoid contact in this area during a rear impact crash scenario.

Overall the results of the virtual performance analysis successfully demonstrated the validity of the advanced CNG module concept while highlighting areas for final design optimization with a view to proposing this solution for mass production on a vehicle with this layout.

In terms of the respective investments and variable costs related to manufacturing and the productions process, an analysis was performed focusing on the CNG system components, the under-body transformation, and the assembly of the vehicle. Since projected production volumes affect not only proportional investment costs, but also the selection of the most appropriate and cost-effective production technologies, comparisons were made considering a range of typical production volumes which, depending on the extent of market penetration, might be expected for a vehicle of this segment namely a medium level of between 20,000 and 50000 vehicle per year and a high level of 100,000 vehicles per year.

From the results of this comparison it would appear that the option of using neck mounting as opposed to independent strap mounting is more expensive overall. However it is important to note that this analysis has been conducted specifically with respect to the B-segment vehicle selected for this activity and its transformation in order to achieve the pre-defined CNG storage capacity. In

practical terms, for this vehicle the independent strap mounting would not be feasible since more space would be required for the single production line to enable the independent mounting of three vessels which is typically unavailable in an existing production plant; instead the modular configuration using neck-mounted vessels enables the possibility of secondary lines running in parallel with the main production line. This represents an important practical advantage of which tends to offset the slightly higher costs estimated for this specific case.

## **Sub Project B2 – Aftertreatment for passenger cars CNG engines**

Sub-Project B2 “Aftertreatment for passenger car CNG engine” deals with the development of an aftertreatment system for natural gas vehicles with special regards to CH<sub>4</sub> conversion efficiency under stoichiometric conditions and NO<sub>x</sub> abatement under lean conditions. Three technical approaches are considered: The first one consists of the development of new catalyst formulations with better methane light-off temperature, the second one consists of a catalytic coated counter current heat exchanger and the last one focuses on engine measures enabling a faster heat-up and a better management of the catalytic systems.

### **Advanced catalyst development**

As a very stable molecule methane requires high temperatures to be oxidized and therefore the abatement of unburned methane still remains a demanding challenge in respect of the today emission limit of 100 mg/km introduced in EURO5/6 regulations for total hydrocarbon (THC). In order to be able to meet these limits the main objective in the catalyst technology development inside the project has been the development of new catalyst formulations for mainly methane oxidation with a light off temperature below 350°C and a high thermal and sulfur stability. In addition, to establish new catalyst candidates in real manufacturing, the development of coating methods and up-scaling have been considered. To support the engine management modeling, kinetic data and the control strategy for methane and NO<sub>x</sub> abatement have been examined.

#### Mixed oxides:

The work on mixed oxide catalyst optimization aimed at the enhancement of the catalytic activity and improvement of the resistance against thermal degradation. The approach focused on the doping of the mixed oxide precursor with palladium, modification of the support, optimization of the synthetic procedure of the hydrotalcite derived CuMn catalyst and modification of the synthetic procedure of thermally stable low surface area oxide phase. Therefore, several mixed oxide powders were examined, characterized and tested including spinels, perovskites, hexaaluminates and pillared clays containing: Cu, Mn, Co, Cr, Ce, Zr, Pd, La and Al. Among the over 120 catalyst formulations tested, Cu-Mn spinel phases obtained by the sol-gel method or derived from hydrotalcite precursors were the most promising. 2<sup>nd</sup> generation catalyst based on the CuMnAl(2,5:5:1) hydrotalcite structure doped with 2-wt% of Pd showed the best light off performance for methane especially when using modified synthetic procedure by shortening the time of interaction between the support and metal salt solution. Although the catalytic performance was found favorable with the literature data, the performance was not sufficient for the requirements set by the boundary conditions of the CNG aftertreatment catalyst.

#### Palladium based catalysts:

Another approach in the methane catalyst development has been to focus on noble metal (mainly palladium) based formulations. For the development of novel catalyst formulations some main

classes have been considered like Pd-only catalyst supported onto different oxides and parallel Pt-Pd samples in the similar carriers. Among the different support materials the optimal Pd/support interactions have been found with  $\text{CeO}_2\text{-Al}_2\text{O}_3$  and it increases the specific activity towards methane. In the laboratory it was found that Pt adding may increase activity, but is detrimental on Pd redox reaction. On the other hand, after long term ageing at engine, Pt was found to increase thermal durability of the Pd-Rh catalyst. The new Pd/ $\text{CeO}_2\text{-Al}_2\text{O}_3$  catalyst has a smoother activation trend and has superior methane oxidation activity with respect of the lower loaded alumina samples and the Pd-based commercial reference catalyst at corresponding loading. The isothermal testing of monolith samples in laboratory showed that the observations found in powder stage could be supported also in real catalyst samples: new Pd/ $\text{CeO}_2\text{-Al}_2\text{O}_3$  powder based catalyst provides superior methane conversion performances, particularly in the lean part of the lambda sweep cycle and at high temperatures. It is also found that the new catalyst is more robust against thermally ageing. In addition, both the Pd-containing catalyst powders and the real monolith catalyst samples were examined for the sulfur poisoning and the regeneration behaviour. The results showed that deep deactivation occurs upon sulfur poisoning, but a significant recovery of the activity can be achieved after thermal treatments, especially under reducing conditions. In particular for Pd/ $\text{CeO}_2\text{-Al}_2\text{O}_3$  catalyst an almost complete recovery of the activity was obtained at 650°C using rich pulses and at 850°C under lean atmosphere. Light off tests at the laboratory scale for the real monolith catalyst samples at adiabatic conditions showed that at lean and stoichiometric conditions about 80°C and 20°C decrease of the light off temperatures for methane after severe ageing were achieved for the new Pd/ $\text{CeO}_2\text{-Al}_2\text{O}_3$  powder based catalyst compared to the corresponding Pd-based reference catalyst. Light off temperatures were about 350°C and 360°C for the lean and stoichiometric conditions after the ageing, respectively (Figure B2.1). In addition, at stoichiometric conditions the methane conversion at higher temperatures after light off showed superior performance for the new catalyst compared to that of the reference one. In that respect, at the laboratory testing conditions the project target (light off less than 350°C for methane) was practically achieved.

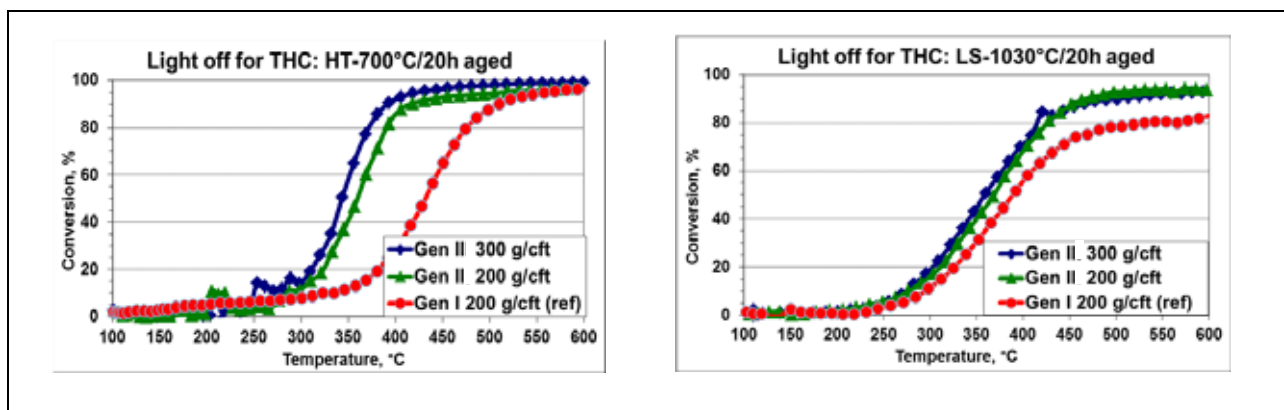

Figure B2.1: Methane conversion =  $f$  (temperature) under lean conditions (**left**) and stoichiometric conditions (**right**) - Gen I: Pd/ $\text{Al}_2\text{O}_3$  (reference); Gen II: Pd/ $\text{CeO}_2\text{-Al}_2\text{O}_3$

#### Scale up and coating:

In order to establish the catalyst behaviour in real size the scale up and the coating methods for the catalyst powders were examined and developed. During the scale up and coating examinations both 6-% Pd/ $\text{CeO}_2\text{-Al}_2\text{O}_3$  and 9-% Pd/ $\text{CeO}_2\text{-Al}_2\text{O}_3$  powder were used in order to be ready to make catalysts both at 200 and 300 g/cft loading levels. Catalyst powder was mixed with alumina binder material and made for the slurry mixing with water and milled for the proper particle size and

viscosity values. As a result good coating abilities and adhesion were found both on the metal surface and ceramic substrates. During the scale up the method for the preparation of kilogram scale of the catalyst powder from small laboratory scale was developed.

As a conclusion of the catalyst development work, the mixed oxide route for developing the new methane catalysts was not successful despite the positive results in respect of the literature data, while very good results with Pd-based catalyst supported on the  $\text{CeO}_2\text{-Al}_2\text{O}_3$  powder were achieved. The light off temperature found for the new catalyst both at the laboratory and the engine bench conditions was under or very near the project target for methane ( $<350^\circ\text{C}$ ).

### Coated heat exchanger

Heat-integrated exhaust purification concepts for CNG engines have been developed and studied by detailed simulation and verified by laboratory and bench scale tests. The specific challenge is the provision of sufficiently high catalyst temperatures ( $>400^\circ\text{C}$ ) for the required methane conversion. For optimized exhaust purification, a counter-current metallic heat exchanger (HEX) coated with the reference Pd/Rh-based three-way-catalyst was developed. With this approach, the adiabatic temperature increase  $\Delta T_{ad}$  during oxidative conversion of pollutants is amplified due to counter-current heat exchange between inflowing and outflowing gas, providing the required high catalyst temperatures even with considerably colder exhaust (Figure B2.2 left). Experimental results depicted in Figure B2.2 (right) show, that in a realistic system,  $\Delta T_{ad}$  is amplified with factors between 4 and 5.

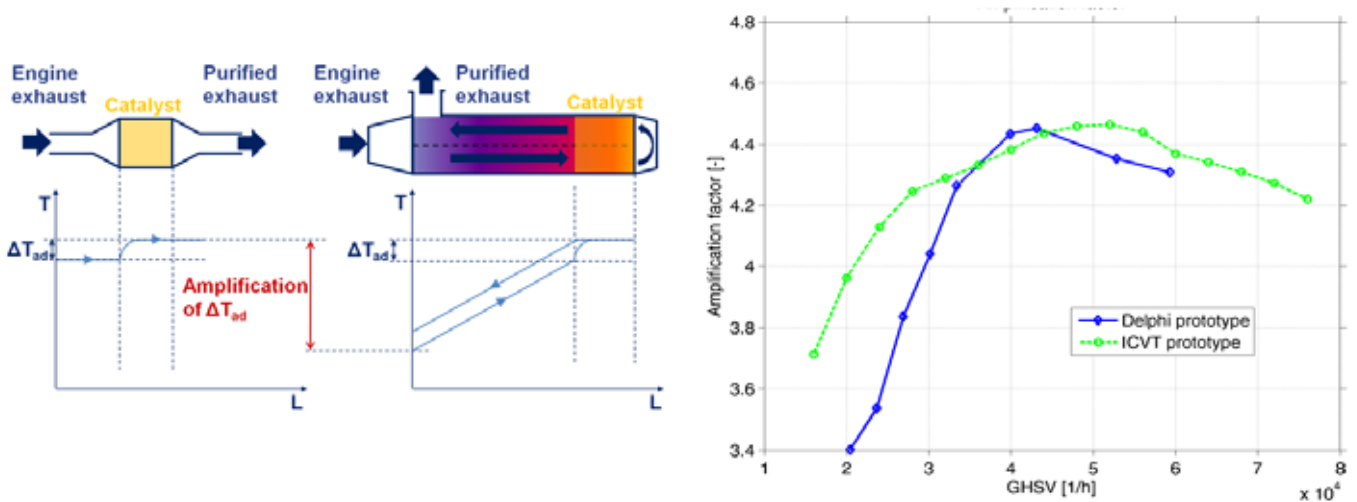

Figure B2.2: Principle of heat integrated system (left); Measured amplification factor of  $\Delta T_{ad}$  versus gas hourly space velocity (GHSV) (right)

In the course of this project, a new HEX design based on a brazed stack of flat tubes (Figure B2.3) was developed and manufactured.

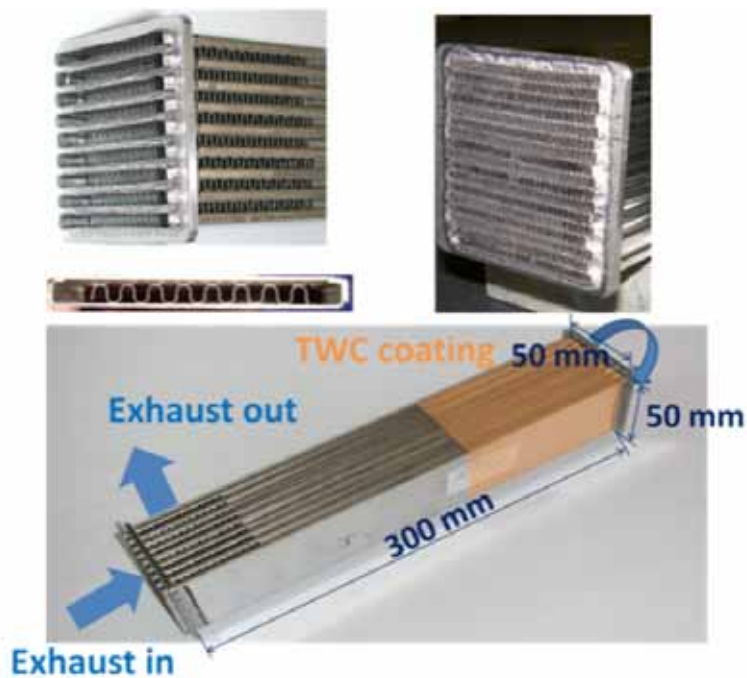

Figure B2.3: Brazed HEX design, top left: cold end with axial inflow/sideways outflow and one flat tube in detail, top right: hot end with increased free surface, bottom: complete HEX with dimensions and indicated coated zone

The advantage of this design approach is its proven manufacturability. However, the required relatively thick walls, necessary for safe brazing resulted in a high thermal mass of the HEX. Since rapid catalyst heating during cold start plays a crucial role in decreasing pollutant emissions, special transient operating strategies needed to be developed during the project. In Figure B2.4, a schematic of the final concept is depicted. With a simple exhaust flap, the engine exhaust can be fed directly into the coated part of the HEX during cold start. For optimized performance, the heating strategy performed with the engine (i.e. late ignition and/or lambda unbalancing for high CO/H<sub>2</sub> content) can be supported with an electric heater. This option is regarded to be more advantageous than a previously considered fuel burner, since no secondary emissions are formed and the air-to-fuel ratio of the exhaust is not affected.

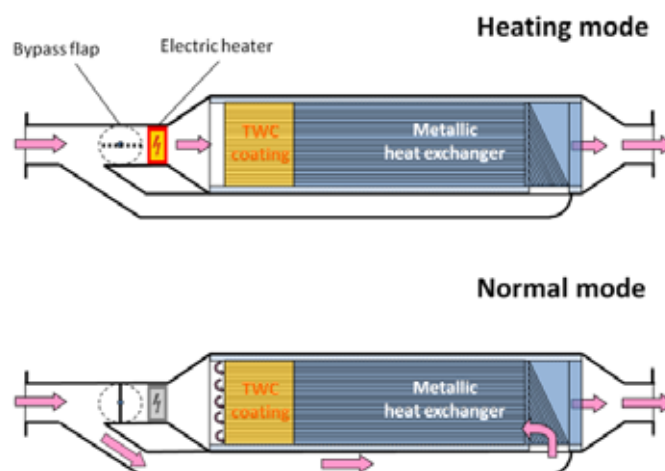

Figure B2.4: Operating modes of HEX with electric heater and bypass flap

After sufficient heating, the bypass flap is closed and the HEX is operated without further auxiliary power input in counter-current flow configuration. In case of high exhaust temperatures, the flap is opened again and the exhaust passes through catalyst and the outflow channels. Hence, the heat amplification effect can be deactivated and the backpressure is significantly lower, which is of special interest under full load conditions. With this strategy the backpressure of the HEX system can be kept below 100 mbar even at full load.

In order to find an optimal operating strategy for the bypass system under drive cycle conditions, a simulation model of the HEX system was set up with appropriate dimensions and raw emission data from a CNG powered vehicle, performing a NEDC sequence on a dynamometer test bench was assumed as inflow. Then, the optimal transition from bypass mode to normal operation was determined based on optimization runs with minimum emission as target. During the bypass phase, different auxiliary power inputs between 0 and 3 kW were assumed. The amount of accumulated  $\text{CH}_4$  emissions during the complete cycle for the different cases is depicted in Figure B2.5.

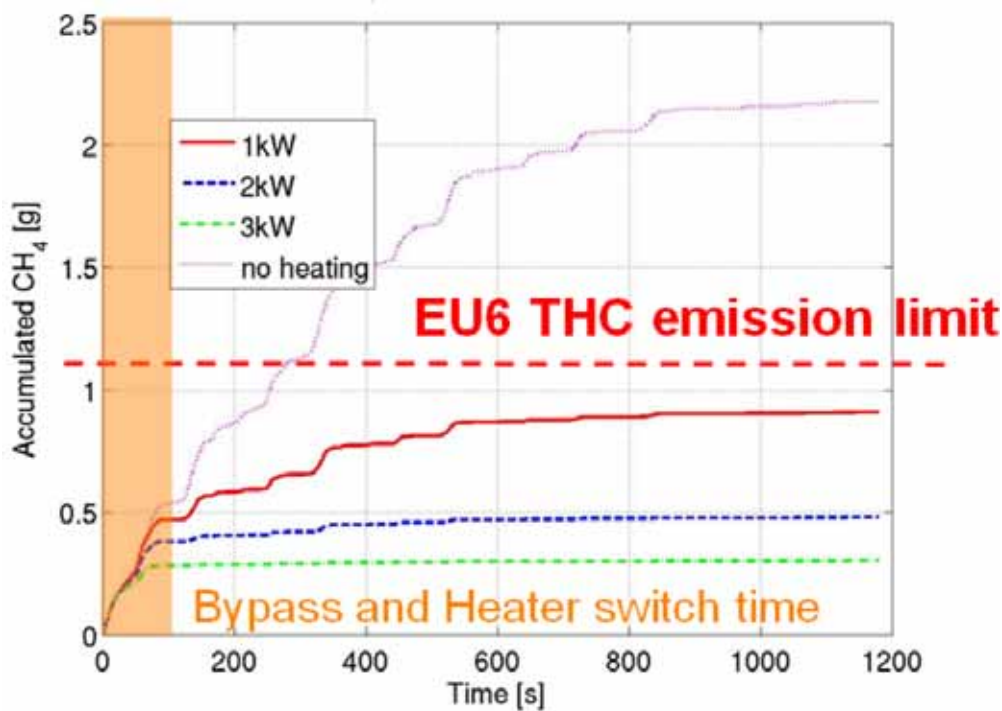

Figure B2.5: Accumulated  $\text{CH}_4$  emissions for different auxiliary power inputs during heating phase

Without auxiliary power input, full conversion is reached towards the end of the drive cycle and the EURO 6 limit is exceeded. However, with a small additional heating input of 1 kW during the initial 90 seconds of the cycle, much higher conversion values were obtained over the remaining cycle. Hence, for optimal HEX performance, auxiliary heating has to occur as close as possible to the catalyst coating and heat losses to the environment have to be minimized. In order to decrease the required amount of auxiliary heating, the thermal mass of the HEX has to be further decreased.

The above simulations have been performed assuming a lambda-controlled three-way catalyst. Further simulations assuming a lean burn engine with  $\text{NO}_x$  storage catalyst (NSC) revealed that the NSC should be placed after the heat exchanger containing the oxidation catalyst for lean conversion of  $\text{CH}_4$  in order to operate both catalysts in an optimal temperature range.

## Engine measures and characterization of the systems on the engine test bench

### Operation strategy for three way catalyst (TWC) to increase the $CH_4$ conversion efficiency:

One objective of subproject B2 was to develop suitable operation strategies for rapid catalyst heat-up and for catalyst keeping warm.

For the catalyst heating phase (before light-off) the target is to produce minimum engine out emissions (especially THC) at increased temperature to heat up the cold catalyst matrix. Finally it was found out that the best operation strategy is a homogeneous, slightly lean mixture combined with late ignition. The possibility of multiple injections with direct injection did not show any benefits.

The commonly used forced lambda oscillation like in gasoline applications is not sufficient to keep the catalyst temperature within the necessary conversion window over the whole test cycle. Therefore for catalyst keeping warm, a controlled cylinder unbalancing strategy has proven to be the most efficient method providing the extra energy to the catalyst. It is significantly more efficient than spark retardation.

### Operation strategy for control of the heat exchanger:

The HEX can be seen as a catalyst with internal heat recuperation. In principal the strategies are the same as for a TWC when considering the engine control aspects. Important is to develop the right operation strategy for controlling the flow through the HEX depending on the operation mode of the engine. It was found that a direct flow to the coated matrix is necessary for catalyst heating. For low engine load the heat exchange is used by switching the flaps to the counter current mode where the exothermic energy is transferred to the inflowing exhaust gas. At high load and full load the heat exchanger operation is by-passed in order to avoid a thermal damage of the HEX as represented in Figure B2.6.

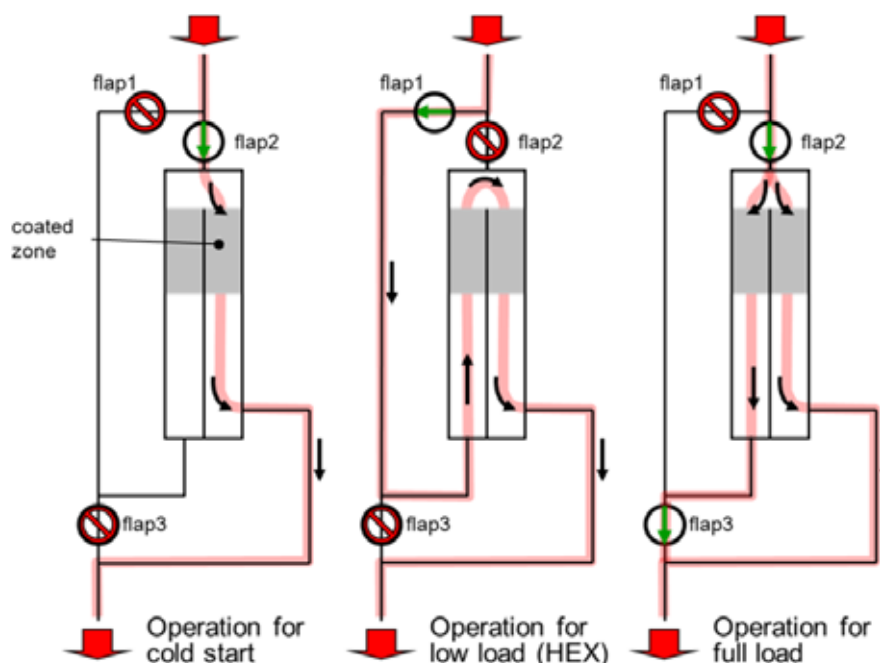

Figure B2.6: HEX operation strategy

Catalyst characterization on the engine test bed (steady-state, transient):

The different coatings developed in subproject B2 were tested in stationary operation mode on the INGAS engine test bench in order to evaluate the CH<sub>4</sub> conversion efficiency with different operation strategies for fresh and aged catalysts. After ageing both the reference catalyst and the Pd/CeO<sub>2</sub>-Al<sub>2</sub>O<sub>3</sub> powder based catalyst exhibit a light off temperature around 340°C. Additionally, advanced operation strategies as described above enabled a faster heat-up of the system and therefore a faster light-off. For all coatings the optimal lambda window for high conversion is below 1.00 and depending on the load point the optimal value can be around 0.98 for the very low loads.

The performance test over the driving cycle (NEDC) showed that again both the reference catalyst and the Pd/CeO<sub>2</sub>-Al<sub>2</sub>O<sub>3</sub> based catalyst worked better than the commercial one despite the lower loading (200 vs. 300 g/cft) and after thermal ageing. With the best catalyst EURO 6 level for THC was not fully reached (111%) due to injector unstability, but in cold start phase (up to 100s) emissions were around 50 mg/km (Figure B2.7). This result is promising when taking account that the tests were performed only with one monolith in close coupled position while the vehicle is normally equipped with a second underfloor catalyst.

In addition, the tests over the driving cycle showed a good possibility to use the new catalyst materials for the methane abatement in order to reach EURO 6 emission levels.

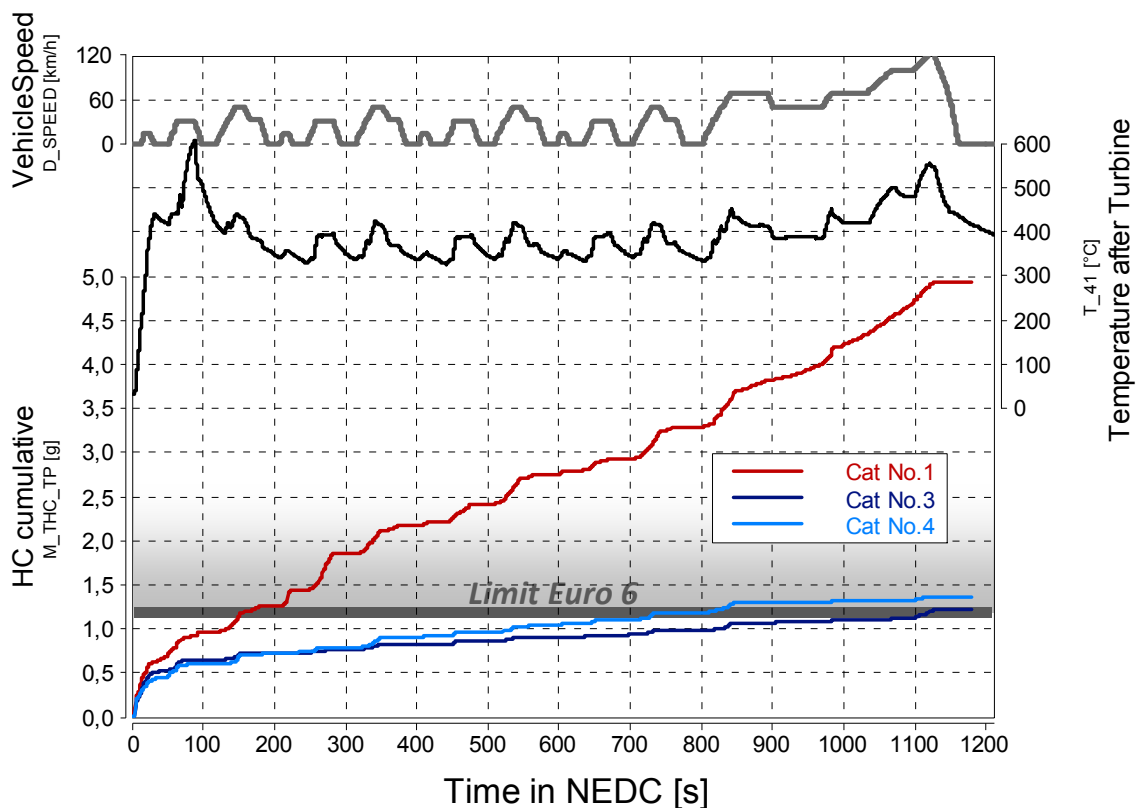

Figure B2.7: Catalyst testing in NEDC driving cycle

Cat 1: commercial catalyst (Pt/Pd/Rh 300g/ft<sup>3</sup>)

Cat 3: Reference catalyst (Pd/Rh 200g/ft<sup>3</sup>)

Cat 4: new material (Pt/Pd/Rh 200g/ft<sup>3</sup>)



## 1.4 Potential Impact

### **CNG technologies for passenger cars**

Technologies developed in SP A1 have demonstrated the huge potential in lowering noxious and CO<sub>2</sub> emissions by matching advanced solutions for stoichiometric internal combustion engines and Natural Gas. The combination of the downsizing + turbocharging + variable valve actuation system approach enables, on one side, to increase the torque and power density of the engine offering a good low-end torque behaviour and the opportunity to close the performance gap compared to the gasoline units. On the other side, 3-ways catalyst technology has also demonstrated its robustness in ensuring high conversion efficiency able to fulfill emissions standards even over Euro 6 limits at acceptable technology cost.

The engine system developed in SP A1 has also been designed taking into account the possible variations in gas composition through European countries and, to support gas quality identification via SW algorithms, an innovative gas quality sensor developed in SP B0 has been deeply investigated and assessed both on engine and on the validator vehicle; the prototype sample has demonstrated the validity of the technical concept and a further integration onto the Engine Management System could provide a wider flexibility to a same engine configuration through different markets.

Another interesting topic is the demonstration done during the project of the capability to use natural gas/hydrogen blends (some tests have been done even with a 40% by volume H<sub>2</sub> concentration) with the same engine technology developed for the natural gas applications. A right metering of hydrogen into the natural gas provides not only an immediate reduction in tailpipe CO<sub>2</sub> emissions but also induces a more complete combustion process with a lower formation of THC and CO. Thanks to its characteristics these blends enable a more important amount of EGR rate (and more generally charge dilution) for a better control of NO<sub>x</sub> emissions and of in cylinder gas temperatures.

This approach results beneficial for a short term introduction of “green” hydrogen at sustainable costs; in a short-medium time horizon it is possible to draw a scenario where NGV could be designed, in terms of engine management system and component materials, to run also with these kind of blends with a wide potential of diffusion all over the NG market.

This in addition to the perspective of a more and more significant introduction of biomethane as transportation fuel issued from biomass conversion processes; thanks to its characteristics, in fact, biomethane can be easily mixed to fossil natural gas into the distribution pipeline network or directly used as pure fuel in the internal combustion engines. In this way natural gas engine technologies could represent an effective solution not only to control the air quality but also to significantly increase the use of renewable energy sources through Europe.

The completion of the activities on the validator vehicle, including the development of a dedicated CNG storage system based on Type IV vessels, has also demonstrated that a C-segment vehicle could achieve an appreciable driving range (500 km) with no extra weight load compared to a conventional CNG storage system providing a “conventional” range by 250 km. This is also a fundamental aspect for the customer acceptance of the CNG technologies taking into account the current distribution of public filling stations and the need in offering more significant CNG driving range as far as moving towards higher vehicle market segments.

Finally, the technologies developed in SP A1 have demonstrated a huge potential for a short medium term strategy where NG could play a growing role in the EU transportation fuels panel; this potential is also supported by the economical sustainability of this approach as most of the engine technologies are in sharing with the gasoline engine platforms (downsizing / turbocharging / variable valve actuation system / 3-ways catalyst) offering higher production volumes to contain the

variable costs. The cost estimation of the developed system indicates an overall extra engine cost by 20% compared with a conventional TC engine, including the integration of innovative gas quality sensor and electronically controlled pressure regulator.

### **Turbo DI CNG engine**

Despite the environmental and fuel economy aspect of natural gas vehicles, performance and fun-to-drive is one of the strongest factors for end-customer buying decision. The Diesel-boom in Europe underlines this trend. Here mainly the good low-end-torque capability together with low fuel costs is the driver. Therefore the outstanding fun-to-drive of the INGAS CNG DI engine might be one of the most important results of SPA2 showing a technology that fits exactly the customer wish. Also from fuel cost side CNG offers an attractive alternative.

Within INGAS subproject A2, the main targets according to the project targets were achieved and/or demonstrated:

- Performance targets with respect to torque and power density and fun-to-drive were achieved
- Potential for EURO 6 and future emission legislations was demonstrated
- Fuel economy in combination with state-of-the-art down-sizing and down-speeding concepts could be quantified and showed a remarkable benefit.
- A functional prototype of a CNG DI injector was developed
- New ECU functionalities for CNG DI were implemented in the engine ECU
- Validation of CFD simulations and code by experimental investigations

The injector as key-component for gas direct injection stays the most challenging HW component with respect to series production. The INGAS solution is not yet series prove, but it clearly shows the weak points to be improved. A further consequent development especially pushed by Tier 1 suppliers should be supported by OEMs but also by public authorities.

A further output and technical innovation is the electronic pressure control device (ePCD) based on a Piezo actuator. This component has already reached a development status close to series production quality. A commercialization could be done with relatively low effort.

The main technical innovations despite the HW components are dedicated to operation strategies and ECU functionalities. Here significant knowledge was generated that can be transferred to next generation CNG engines and help utilizing the potential this fuel offers regarding emissions and efficiency.

The innovations in the field of engine operation strategy and engine control could be exploited with very little further development effort to next generation CNG engines for mass production, enabling CNG optimized Turbocharged engines with less compromises due to aftertreatment reasons. A significant part of the developed operation strategies can be transferred also to port injected CNG engines gathering significant benefits.

The future commercial exploitation of the developments made within the INGAS SPA2 may help to achieve a deeper market penetration and customer acceptance, utilizing the benefits of CNG as fuel in terms of CO<sub>2</sub> and particulate emission reduction. The low pollutant emissions and here especially the low particulate emissions make CNG vehicles interesting especially for urban areas. In subproject A2 also the impact of direct injection on particulates was investigated, with the result that also CNG direct injection the particulate number is one magnitude below future particulate limits. Even better is the situation on particulate matter were the emission is below 1% of the EURO 6 limit. With respect to discussions about urban low emission zones and healthiness of the residents in urban areas this factor might have a significant socio-economic impact.

### **Fuels for advanced CNG engines**

The optimization of CNG engines on the one hand and the maintenance fuel flexibility with respect to different gas qualities on the other hand are partly oppositional objectives. The results of subproject B0 contribute to advanced CNG engine solutions with improved performance and with the capability to run properly with the appropriate range of fuel qualities. It was one of the tasks of this subproject to define this range by the selection of limit gases. These limit gases reflect the current and future gas supply situation in Europe and the perspective of a hydrogen admixture from renewable sources. By this means, the interests in both an economic and ecologically friendly gas supply and the progress of CNG vehicle technology are balanced.

The results of the INGAS project are valuable as a basis for future standardization efforts. In Germany, a standard for natural gas as a fuel already exists. The planned activities for the amendment of this standard (especially the specification of the still missing limit value for particles and oil in CNG) will benefit from the knowledge gained during the project

### **Gas storage for passenger cars CNG engines**

Within INGAS devoted also to gas storage, all the main specified performance targets were achieved in terms of:

- proposing new modular design and construction concepts for advanced CNG vehicles
- enabling extended vehicle range by virtue of the advanced, highly-integrated CNG storage module
- developing and validating advanced CNG storage components (valves and electronic pressure regulator)
- ensuring full compatibility of the components of the system
- assessing the EC regulations ECE R110 via scientific validation.

The additional cost of current-production CNG vehicles compared to the gasoline/diesel derivative results mainly from costs of the storage components and from higher vehicle assembly costs. These vehicles are normally converted offline – outside the conventional assembly lines – on lifting platforms. In this project it has been possible to demonstrate that the integration into the assembly lines of the conventional gasoline and diesel derivative would be feasible by virtue of the modular CNG storage system concepts, which can be preassembled and tested outside the vehicle assembly lines.

Overall the project delivered technical solutions of considerable interest and relevance from an industrial perspective being both innovative and economically viable, particular as regards:

- the advanced CNG thermoset vessel design based on a glass and carbon hybrid composite structure developed, validated and realized by Xperion within the project, and tested extensively by BAM and WRUT, which offers a technically valid and sustainable solution for the innovative lightweight, low-cost composite vessels for the on-board storage of CNG;
- the new generation of an electronic pressure regulator and advanced in-tank shut off valves developed, realized and tested by Ventrex which offer significant advantages in terms of dimensions, weight, number of components and cost with respect to previous versions of these innovative, high-precisions components;
- the advanced CNG storage module concept using Hybrid composite Type IV vessels attached to the vehicle via neck mounting which was developed, validated, realized and tested by CRF.

In general, these innovations could be exploited with very little further development to next generation CNG vehicles for mass production, thus overcoming the main obstacles for mass-market entry of CNG vehicles related to the storage system, namely:

- the driving range which is typically limited to less than 350-400km in the CNG mode
- significantly higher vehicle kerb weight of CNG vehicles compared with gasoline or diesel vehicles due to the weight of the CNG storage system
- inferior vehicle performance, particularly in terms of handling, acceleration and braking, due to the higher mass of the CNG storage system
- higher vehicle costs and hence longer payback time for the higher initial investment when purchasing the vehicle.

In this context, the future commercial exploitation of the developments made within INGAS Project will provide a significant boost to the prospects that CNG vehicles achieve significant market penetration over the coming 2-5 years, enabling the well-known benefits of CNG in terms of reduced CO2 emissions and impact on the environment to be realized.

## 1.6 Project website address

[www.ingas-eu.org](http://www.ingas-eu.org)

Beneficiaries		
Short Name	Name	Country
CRF (coord.)	Centro Ricerche Fiat SCpA	IT
AVL	AVL List GmbH	AT
FEV	FEV Motorentechnik GmbH	DE
EON-RUHR	E.ON Ruhrgas AG	DE
DAI	Daimler AG	DE
SAPT	SAAB Automobile Powertrain AB	SE
GMPT-G	General Motors Powertrain Germany – GmbH	DE
GDF SUEZ	GDF SUEZ	FR
IFPEN	Institut Français du Pétrole	FR
CNR-IM	Consiglio Nazionale delle Ricerche	IT
TU-GRAZ	Graz University of Technology	AT
ECOCAT	Ecocat Oy	FI
CONTI	Continental Automotive GmbH	DE
SIEMENS	Siemens Aktiengesellschaft	DE
PT	Politecnico di Torino	IT
CHALMERS	Chalmers Tekniska Högskola AB	SE
HT	Haldor Topsøe A/S	DA
RWTH	Rheinisch Westfälische Technische Hochschule Aachen	DE
MEMS	MEMS AG	CH
CVUT-JBRC	ČVUT v Praze	CZ
XPERION	ALPHA Composites GmbH	DE
VENTREX	VENTREX Automotive GmbH	AT
BAM	Bundesanstalt für Materialforschung und -prüfung	DE
WRUT	Wroclaw University of Technology	PL
DELPHI	Delphi Automotive Systems Luxembourg S.A.	LX
ICVT	Universität Stuttgart	DE
POLIMI	Politecnico di Milano	IT
ICSC-PAS	Institute of Catalysis and Surface Chemistry Polish Academy of Sciences	PL
KATCON	KATCON Global SA	LX
OPEL	Adam OPEL GmbH	DE

## 2. Use and dissemination of foreground

### Section A

TEMPLATE A1: LIST OF SCIENTIFIC (PEER REVIEWED) PUBLICATIONS, STARTING WITH THE MOST IMPORTANT ONES

N.	Title	Main author	Title of the periodical or the series	Number, date or frequency	Publisher	Place of publication	Year of publication	Relevant pages	Permanent identifiers <sup>2</sup> (if available)	Is/Will open access <sup>3</sup> provided to this publication?
1	<i>New clean fuels herald green motoring revolution</i>	CRF	<i>Projects magazine</i>	<i>October 2010</i>	<i>Insight Publisher</i>	<i>Web</i>	<i>2010</i>	<i>pp. 61 - 63</i>	<a href="http://viewer.zmags.com/publication/374fb128#/374fb128/61">http://viewer.zmags.com/publication/374fb128#/374fb128/61</a>	Yes
2	<i>Mixture Formation and Combustion of Hydrogen/Methane Mixtures in PC-Application</i>	TU Graz	<i>Doctorial Thesis by C. Skalla</i>	<i>June 2011</i>	<i>n.a.</i>	<i>n.a.</i>	<i>2011</i>	<i>n.a.</i>	<i>n.a.</i>	No
3	<i>Effect of natural gas/hydrogen blends on spark ignition stoichiometric engine efficiency</i>	CNR IM	SAE	<i>September 2011</i>	SAE Naples	<i>Web</i>	<i>2011</i>	<i>n.a.</i>	2011-24-0121	<i>Only abstract Full access to SAE members</i>

<sup>2</sup> A permanent identifier should be a persistent link to the published version full text if open access or abstract if article is pay per view) or to the final manuscript accepted for publication (link to article in repository).

<sup>3</sup> Open Access is defined as free of charge access for anyone via Internet. Please answer "yes" if the open access to the publication is already established and also if the embargo period for open access is not yet over but you intend to establish open access afterwards.

4	Numerical and Experimental Analysis of Mixture Formation and Performance in a Direct Injection CNG Engine	Baratta, M., Rapetto, N., Spessa, E., Fuerhapter, A., Philipp, H.	SAE 2012 World Congress	24-26/04/2012	SAE International	Detroit (MI)	2012	22	<a href="http://papers.sae.org/2012-01-0401/">http://papers.sae.org/2012-01-0401/</a>	No
5	DI-CNG Injector Characterization at Small Energizing Times by Means of Numerical Simulation	Baratta, M., Catania, A.E., Rapetto, N., Fuerhapter, A., Gerlich, M., Zoels, W.	2012 ASME ICED Spring Technical Conference	6-9/05/2012	ASME		2012	12		No
6	Computational and Experimental Analysis of Direct CNG Injection and Mixture Formation in a SI Research Engine	Baratta, M., Catania, A.E., Pesce, F.C.	2010 ASME ICED Fall Technical Conference	12-15/09/2012	ASME		2010	17		No
7	Sulfur promoted low-temperature oxidation of methane over ceria supported platinum catalysts	Lisa Kylhammar, Per-Anders Carlsson, Magnus Skoglundh CHALMERS	Journal of Catalysis	vol. 284 (2011)	Elsevier		2011	pp. 50 - 59	<a href="http://dx.doi.org/10.1016/j.jcat.2011.08.018">http://dx.doi.org/10.1016/j.jcat.2011.08.018</a>	Yes
8	Experimental studies of ceria and alumina supported platinum Regenerable sulphur traps and methane oxidation catalysts	Lisa Kylhammar (CHALMERS)	Doktorsavhandlingar vid Chalmers tekniska högskola (PhD theses at Chalmers University of Technology)	Series No: 3216	Chalmers University of Technology	Göteborg, Sweden	2011	pp. 1-54		Yes
9	Einfluss von Verdichteröl aus Erdgastankstellen auf den Betrieb von CNG-Fahrzeugen (in German)	Schollmeyer, H.-J.	gwf Gas Erdgas	No 1-2, Feb. 2012	Oldenbourg Verlag	Munich	2012	78 - 84		Yes

10	<i>Influence of compressor oil from natural gas filling stations on the operation of CNG vehicles</i>	Schollmeyer, H.-J.	gas4energy	No 1, 2012	Oldenbourg Verlag	Munich	2012			Yes
11	<i>Investigation of option to compensate for fuel quality variation by a combination of several control interventions at once</i>	Marcel Skarohlid	MECCA Journal of Middle European Construction and Design of Cars ISSN 1214-0821	No. 03 2011, volume IX	České vysoké učení technické v Praze	Prague, Czech Republic	2011	34-46		Yes
12	<i>Hydrogen containing gaseous blends as vehicle fuels</i>	Michal Takats		No. 02 2011, volume IX			2011	14-20		Yes
13	<i>Correlation of ignition delay for various methane based fuel blends</i>	Vojtech Klir		No. 02 2011, volume IX			2011	21-27		Yes
14	<i>Advanced engine control possibilities to react on fuel features</i>	Marcel Skarohlid		No. 02 2011, volume IX			2011	28-44		Yes
15	<i>Description of the transformation of chemical species using a combination of chemical kinetics and chemical equilibrium</i>	Jiri Hvezda		No. 03 2011 volume IX			2011	28-33		Yes
16	<i>Research on RC&amp;S for Hydrogen Storage Relevant to transport and Vehicle issues with special focus on Composite Containments</i>	P.Pöschko, G.Mair	Proceedings of the International Conference on Hydrogen Safety	9/12/2011	hySafe		2011			No
17	<i>Überwachung der Fertigungsqualität von Faserverbund-Druckbehältern mittels Schallemissionsprüfung</i>	E. Duffner, J. Bohse, C. Gregor	Proceedings of Kolloquium Schallemission der DGZfP	27-28/10/2011	DGZfP	DGZfP BB 131-CD	2011	1-9		Yes
18	<i>SMART high pressure composite vessels for hydrogen storage with integrated Structural Health Monitoring (SHM) system</i>	W.Blazejewski, A. Czulak, P. Gasior, J. Kaleta	Proceedings of the 19th World Hydrogen Energy Conference WHEC 2012	3-7/06/2012			2012			Yes

19	Optical fiber based strain monitoring method for high pressure composite vessels for gaseous fuel storage	P. Gasior	Ph. D. Thesis				2012			
20	Effect of Pt/Pd ratio on catalytic activity and redox behaviour of bimetallic Pt-Pd/Al <sub>2</sub> O <sub>3</sub> catalysts for CH <sub>4</sub> combustion	P. Castellazzi; G. Groppi; P. Forzatti Dipartimento di Energia, Politecnico di Milano, Milano, 20133 Italy	APPLIED CATALYSIS B-ENVIRONMENTAL 95 (2010) 303-311	2010	APPLIED CATALYSIS B-ENVIRONMENTAL		2010	pp. 303-311		yes
21	Optimization of a heat-integrated exhaust catalyst for CNG engines	Rink, M.*1), Nieken, U.1), Tuttlies, U. 1) Eigenberger, G.1) University of Stuttgart, Inst. of Chemical Proc. Eng.	Catalysis Today	2011	Catalysis Today		2011			yes
22	Effect of periodic lean/rich switch on methane conversion over a Pd/Rh-based three way catalyst in the exhausts of natural gas vehicles	D. Bounechada <sup>1</sup> , G. Groppi <sup>1</sup> , P. Forzatti <sup>1</sup> , K. Kallinen <sup>2</sup> , T. Kinnunen <sup>2</sup> 1)Dipartimento di Energia, Politecnico di Milano, Milano, 20133 Italy 2)Ecocat Oy, Typpitie, Oulu, Finland	Accepted for publication on APPLIED CATALYSIS B-ENVIRONMENTAL	2012	APPLIED CATALYSIS B-ENVIRONMENTAL		2012			yes



**TEMPLATE A2: LIST OF DISSEMINATION ACTIVITIES**

N.	Type of activities <sup>4</sup>	Main leader	Title	Date	Place	Type of audience <sup>5</sup>	Size of audience	Countries addressed
1	Conference "Engine combustion process"	TU Graz	<i>Optical Investigation on the Mixing- and Burning Process of Gaseous Fuels in a PC-Size Engine with External Mixture Formation</i>	24 March 2011	Munich	Scientific Community /Industry	> 500 persons	EU
2	SAE Naples Internal Combustion Engines	CNR IM	<i>Effect of natural gas/hydrogen blends on spark ignition stoichiometric engine efficiency</i>	Sept 2011	Capri	Scientific Community , Industry, Policy makers, Medias	> 500 persons	EU
3	Conference	AVL	<i>5<sup>th</sup> Conference Gas Powered Vehicles</i>	30/09/10 – 1/10/10	Berlin	Scientific Community , Industry	~ 200	Worldwide
4	Conference	PT	<i>SAE 2012 World Congress</i>	24-26/04/2012	Detroit (MI)	Scientific Community	About 100	Worldwide
5	Conference	PT	<i>2012 ASME ICED Spring Technical Conference</i>	6-9/05/2012	Torino, Italy	Scientific Community	About 50	Worldwide
6	Conference	PT	<i>ASME ICED Fall Technical Conference</i>	12-15/09/2010	San Antonio (TX)	Scientific Community	About 50	Worldwide

<sup>4</sup> A drop down list allows choosing the dissemination activity: publications, conferences, workshops, web, press releases, flyers, articles published in the popular press, videos, media briefings, presentations, exhibitions, thesis, interviews, films, TV clips, posters, Other.

<sup>5</sup> A drop down list allows choosing the type of public: Scientific Community (higher education, Research), Industry, Civil Society, Policy makers, Medias ('multiple choices' is possible).

7	Academic Lessons	PT	CFD simulation of underexpanded gas flow	Ongoing since P2	Torino, Italy	Students	About 30	Worldwide (international courses)
8	Ph.D. Thesis	PT	CFD simulation of underexpanded gas flow	October, 2008 – December, 2009	Torino, Italy	Scientific Community	About 30	Italy
9	Master thesis	PT	CFD simulation of underexpanded gas flow	September, 2010 – March, 2011	Torino, Italy	Scientific Community	About 30	Italy
10	Ph.D. Thesis	PT	CFD simulation of underexpanded gas flow	Ongoing since January, 2010	Torino, Italy	Scientific Community	About 30	Italy
11	University lecture	RWTH	Combustion system development	ongoing	Aachen	Students, RWTH scientific personnel	150	
12	University lecture	RWTH	Ignition systems for advanced operation strategies	ongoing	Aachen	Students, RWTH scientific personnel	150	
13	University lecture	RWTH	Boosting systems for advanced operation strategies	ongoing	Aachen	Students, RWTH scientific personnel	150	
14	University lecture	RWTH	Process simulation	ongoing	Aachen	Students, RWTH scientific personnel	150	
15	7 <sup>th</sup> International CTI Conference	HT	DeNOx concepts to meet the future legislations: SCR only and SCR on DPF	4-6 July 2011	Stuttgart	Automotive engineers	100	

16	Ph.D. Thesis Defence	CHALMERS	Experimental studies of ceria and alumina supported platinum Regenerable sulphur traps and methane oxidation catalysts	June 17, 2011	Chalmers	Students, Senior academic scientists, Industry R&D personell, Civil Society	100	
17	Presentation	Ph. Prêtre	Low Cost Gasqualitätsbestimmung für den Massenmarkt	07. Nov. 2011	Cologne, Germany	Industry (FIGAWA Arbeitskreis Sensorik)	15	D, NL
18	Conference	BAM	International Conference on Hydrogen Safety	09/12/2011	San Francisco USA	Scientific Community , Industry, Policy makers	300+	International
19	Conference	BAM	Kolloquium Schallemission der DGzFP	27- 28/10/2011	Wetzlar, Germany	Scientific Community	50+	Germany
20	Conference	WRUT	19th World Hydrogen Energy Conference WHEC	3-7/06/2012	Toronto, Canada			
21	Publication	P. Castellazzi; G. Groppi; P. Forzatti Dipartimento di Energia, Politecnico di Milano, Milano, 20133 Italy	Effect of Pt/Pd ratio on catalytic activity and redox behaviour of bimetallic Pt- Pd/Al <sub>2</sub> O <sub>3</sub> catalysts for CH <sub>4</sub> combustion	APPLIED CATALYSIS B- ENVIRONM ENTAL 95 (2010) 303- 311	APPLIED CATALYS IS B- ENVIRON MENTAL	Scientific community		International
22	Publication	Rink, M.*1), Nieken, U.1), Tuttlies, U. 1) Eigenberger, G.1) University of Stuttgart, Inst. of Chemical Proc. Eng.	Optimization of a heat- integrated exhaust catalyst for CNG engines	November 2011	CATALYS IS TODAY	Scientific Community		

23	Publication	D. Bounechada <sup>1</sup> , G. Groppi <sup>1</sup> , P. Forzatti <sup>1</sup> , K. Kallinen <sup>2</sup> , T. Kinnunen <sup>2</sup> 1) Dipartimento di Energia, Politecnico di Milano, Milano, 20133 Italy 2) Ecocat Oy, Typpitie 1, Oulu, 90620 Finland	Effect of periodic lean/rich switch on methane conversion over a Pd/Rh-based three way catalyst in the exhausts of natural gas vehicles	Accepted for publication on APPLIED CATALYSIS B-ENVIRONMENTAL	APPLIED CATALYSIS B-ENVIRONMENTAL	Scientific community		International
24	Conference - World Congress on Oxidation Catalysis	P. Castellazzi; G. Groppi; P. Forzatti Dipartimento di Energia, Politecnico di Milano, Milano, 20133 Italy	Effect of Pt/Pd atomic ratio on CH <sub>4</sub> combustion activity and palladium redox properties of PdPt/Al <sub>2</sub> O <sub>3</sub> catalysts.	2009	Lille, France	Scientific community, Industry	500	International
25	Conference - XLI Annual Polish Conference on Catalysis	R. Dula, M. Zimowska, B. Napruszewska, R. Socha, T. Machej, W. Rojek, E.M. Serwicka ICSC-PAS, Krakow Poland	Hydrotalcite-derived mixed oxide Cu-Mn-Al-O catalysts for methane combustion	April 2009	Krakow, Poland	Scientific community, Industry	200	Poland
26	Conference - Europacat X	D. Bounechada <sup>1</sup> , G. Groppi <sup>1</sup> , P. Forzatti <sup>1</sup> , K. Kallinen <sup>2</sup> and T. Kinnunen <sup>2</sup> 1) Dipartimento di Energia, Politecnico di Milano, Milano, 20133 Italy 2) Ecocat Oy, Typpitie 1, Oulu, 90620 Finland	Effect of lean/rich feed oscillations on methane conversion over a Pd/Rh TWC	28 August - 2 Sept 2011	Glasgow, Scotland	Scientific community, Industry	400	International

27	Conference - 2nd International Symposium on Modelling of Exhaust Gas After Treatment MODEGAT II	Rink, M.*1), Nieken, U.1), Eigenberger, G.1) University of Stuttgart, Institute of Chemical Process Engineering	Optimization of a heat- integrated exhaust catalyst for CNG engines	September 2011	2nd Internatio nal Symposiu m on Modelling of Exhaust Gas After Treatment MODEGA T II, Bad Herrenalb , Germany	Scientific community, Industry	300	International
28	Presentation PhD Thesis	Bounechada Djamela Dipartimento di Energia, Politecnico di Milano, Milano, 20133 Italy	Strategies for the enhancement of low temperature catalytic oxidation of methane emissions	March 2012	Politecnic o di Milano, Milano, Italy	Scientific community, students	30	Italy
29	Conference - Jahrestreffen Reaktionstechnik	Rink, M.1), Nieken, U.1), Eigenberger, G.1) University of Stuttgart, Institute of Chemical Process Engineering, D- 70199 Stuttgart, Germany	Heat-integrated, sequential exhaust purification system for monovalent CNG engines	May 2012	Jahrestref fen Reaktions technik, Würzburg , Germany	Scientific community	200	Germany

30	Conference - CAPoC 9	D. Bounechada <sup>1</sup> , G. Groppi <sup>1</sup> , P. Forzatti <sup>1</sup> , K. Kallinen <sup>2</sup> and T. Kinnunen <sup>2</sup> 1) Dipartimento di Energia, Politecnico di Milano, Milano, 20133 Italy 2) Ecocat Oy, Typpitie 1, Oulu, 90620 Finland	Enhanced methane conversion under periodic operation over a Pd/Rh based TWC in the exhaust from NGVs	August 2012	CAPoC 9, Brussels	Scientific community, Industry	500	international
31	Conference - CAPoC 9	Rink, M.1), Nieken, U.1), Eigenberger, G.1), Weibel, M.2), Rappe, T.2), Fürhapter, A.3), Certic, M.3), Ayad, F. 4) 1) Univ. Stuttgart, Inst. of Chemical Process Eng., D-70199 Stuttgart, Germany 2) Daimler AG, D-70546 Stuttgart, Germany 3) AVL List GmbH, Hans-List-Platz 1, A-8020 Graz, Austria 4) Delphi Automotive Systems Luxembourg SA, Luxembourg	Heat-integrated exhaust purification for monovalent CNG engines	August 2012	CAPoC 9, Brussels	Scientific community, Industry	500	international

## Section B

### Part B1

<b>TEMPLATE B1: LIST OF APPLICATIONS FOR PATENTS, TRADEMARKS, REGISTERED DESIGNS, ETC.</b>					
Type of IP Rights <sup>6</sup> :	Confidential Click on YES/NO	Foreseen embargo date dd/mm/yyyy	Application reference(s) (e.g. EP123456)	Subject or title of application	Applicant (s) (as on the application)
Patent	no	17.06.2010	DE 10 2010 017 413 A1	Druckbehälter zum Speichern eines Fluides	Michael Kleschinski Dietmar Müller

<sup>6</sup> A drop down list allows choosing the type of IP rights: Patents, Trademarks, Registered designs, Utility models, Others.

**Part B2**

Type of Exploitable Foreground <sup>7</sup>	Description of exploitable foreground	Confidential Click on YES/NO	Foresee n embargo date dd/mm/yyyy	Exploitable product(s) or measure(s)	Sector(s) of application <sup>8</sup>	Timetable, commercial or any other use	Patents or other IPR exploitation (licences)	Owner & Other Beneficiary(s) involved
General advancement of knowledge	NG / H2 BLENDS COMBUSTION PROCESS	NO	N.A.	COMBUSTION PROCESS OPTIMIZATION	C29.1 – C29.3	AVAILABLE	NOT DEVELOPED IN THE PROJECT	N.A.
Commercial exploitation of R&D results	CNG DEDICATED ENGINE TECHNOLOGY	NO	N.A.	CNG DEDICATED ADVANCED ENGINE	C29.1 – C29.3	2013	NOT DEVELOPED IN THE PROJECT	N.A.
General advancement of knowledge	Advanced CNG DI Combustion Design	Yes	31.05.2015	CNG DI Combustion Concept	C29.1 - Manufacture of motor vehicles	open		AVL, Daimler
General advancement of knowledge	Transient Control Strategies for CNG engines	Yes	31.05.2015	Engine Calibration Data	C29.1 - Manufacture of motor vehicles	2013		AVL
General advancement of knowledge	Improved functionality for gas pressure control	Yes	11.05.2015	Engine Management System	C29.1 - Manufacture of motor vehicles	2013	-	CONTI, car manufacturers
General advancement of knowledge	Functionality for gas direct injection	Yes	11.05.2015	Engine Management	C29.1 - Manufacture of motor vehicles	open	-	CONTI, car manufacturers

<sup>19</sup> A drop down list allows choosing the type of foreground: General advancement of knowledge, Commercial exploitation of R&D results, Exploitation of R&D results via standards, exploitation of results through EU policies, exploitation of results through (social) innovation.

<sup>8</sup> A drop down list allows choosing the type sector (NACE nomenclature) : [http://ec.europa.eu/competition/mergers/cases/index/nace\\_all.html](http://ec.europa.eu/competition/mergers/cases/index/nace_all.html)



Type of Exploitable Foreground <sup>7</sup>	Description of exploitable foreground	Confidential Click on YES/NO	Foreseen embargo date dd/mm/yyyy	Exploitable product(s) or measure(s)	Sector(s) of application <sup>8</sup>	Timetable, commercial or any other use	Patents or other IPR exploitation (licences)	Owner & Other Beneficiary(s) involved
				System				
General advancement of knowledge	Layout and design of DI CNG system	Yes	31/12/2015	DI CNG engine	C29.1 - Manufacture of motor vehicles	open	-	Daimler, Conti, Siemens CT, AVL
General advancement of knowledge	Catalyst heating with DI CNG engine	Yes	31/12/2015	Method for DI CNG engines	C29.1 - Manufacture of motor vehicles	open	-	Daimler, AVL
General advancement of knowledge	Knowledge of underexpanded gas jet	NO		Lessons	M72.1 - Research and experimental development on natural sciences and engineering	Ongoing since October, 2009		PT (owner)
General advancement of knowledge	Advanced simulation techniques for compressible flow	Yes		Founded or academic research	M72.1 - Research and experimental development on natural sciences and engineering	From the end of the project on		PT (owner)
Commercial exploitation of R&D results	Increased data base on lean combustion results	Yes			Development		Already existing ATAC patent @ FEV	FEV

Type of Exploitable Foreground <sup>7</sup>	Description of exploitable foreground	Confidential Click on YES/NO	Foreseen embargo date dd/mm/yyyy	Exploitable product(s) or measure(s)	Sector(s) of application <sup>8</sup>	Timetable, commercial or any other use	Patents or other IPR exploitation (licences)	Owner & Other Beneficiary(s) involved
Commercial exploitation of R&D results	Refinement of rapid prototyping EMS	Yes			Development			FEV
Commercial exploitation of R&D results	Validity of process simulation tools	Yes			Development			FEV
Commercial exploitation of R&D results	Methane oxidation formulations	Yes			Development & Marketing		Already existing methane catalyst patent	HT
Commercial exploitation of R&D results	SCR catalyst formulations	Yes			Development & Marketing			HT
Commercial exploitation of R&D results	Exhaust system design	Yes			Development & Marketing			HT
COMMERCIAL EXPLOITATION OF R&D RESULTS	HYBRID DESIGN FOR PRESSURE VESSEL	Yes	2013	CNG PRESSURE VESSELS	AUTOMOTIVE INDUSTRIAL GASTRANSPORT	2013	SEE PART B1	XPERION EE
General advancement of knowledge	Operation strategies for fast catalyst heat-up	NO		Engine control management, ECU functions	Automotive industry, supplier industry			AVL, Daimler

Type of Exploitable Foreground <sup>7</sup>	Description of exploitable foreground	Confidential Click on YES/NO	Foreseen embargo date dd/mm/yyyy	Exploitable product(s) or measure(s)	Sector(s) of application <sup>8</sup>	Timetable, commercial or any other use	Patents or other IPR exploitation (licences)	Owner & Other Beneficiary(s) involved
General advancement of knowledge	Coated heat exchanger for exhaust aftertreatment, operation strategies	NO		Counter current heat exchanger with catalytic coating	Catalyst suppliers, automotive industry, automotive suppliers, universities		Patents ICVT: WO2004/099 577A1 US2006/0096 282A1	USTUTT (owner) Daimler, AVL, Delphi, Katcon, Ecocat
General advancement of knowledge	New catalyst formulations for low-temperature methane conversion	NO		Knowledge about catalyst synthesis and activity for methane oxidation	Universities, catalyst suppliers, automotive industry, other industries for air purification		Patents ICSC-PAS: PL 183796 PL 166598 Patents POLIMI	Polimi, ICSC-PAS, Ecocat, Daimler, AVL
Commercial exploitation of R&D results	New catalyst formulation	NO		Catalyst for CH <sub>4</sub> removal	Catalyst suppliers, automotive industry	Expected in 2013		Ecocat

## Comments

**Sub Project A1.** With regards to the general knowledge issued from the deep experimental activity on the combustion process of natural gas / hydrogen blends, the advances will enable to conceive new flexible CNG engine platforms able not only to run with different NG composition (thanks also to the possible integration of the gas quality sensor) but also with the hydrogen blends. This steps will go through different topic, also dealing with the component material certification, but the outcome from SP A1 activities will allow to optimize the Engine Management System.

Moving to the engine technologies, the concept developed within the CNG stoichiometric dedicated engine will be adopted for the future application on the FIAT Natural Power brand: the next generation of the A/B segment CNG vehicles will be equipped with a strong downsized engine (2 cylinder – 0,9 liter displacement – turbocharged) integrating the variable valve actuation system first applied on CNG during the INGAS project. This application is scheduled for end of 2012 with a production volume potential up to 50 000 units/year.

**Sub Project A2.** AVL: Substantial knowledge regarding design and control of a modern CNG engine concept could be gained in INGAS Project. Control strategies and functionalities have been developed and applied to reach very competitive engine performance and efficiency while fulfilling strict legal regulations. For example for emission reduction an improved methane conversion strategy specifically for CNG engines is applied. As a supplier of automotive engine development AVL can bring such findings instantly into the development process of new concepts. Modern gasoline engines are increasingly equipped with DI-systems. Topics like the durability of the gasoline injection valve and easy conversion of the basic engine into a CNG derivate will enhance the priority of CNG DI concepts – even if there is still some R&D-work to do; especially regarding the injection valves.

DAI: The work within subproject A2 delivered valuable experience and information regarding layout and design of future CNG engines with direct injection of natural gas. The results showed clearly the benefit of direct injection concerning low-end torque. Hence, downsizing of CNG engines will be feasible and considerable potential for lowering CO<sub>2</sub> emission will be realizable. For catalyst heating additional possibilities were found to increase exhaust gas enthalpy and to reduce emissions. Daimler will seek for suppliers, which will carry on the development of this technology. Further research or development work is necessary regarding injector size, durability, leakage and production costs.

PT: PT will exploit its advancement in knowledge about under-expanded gas-flow phenomenology and simulation through the release of advanced applied lectures within Master-degree courses of Automotive as well as Mechanical Engineering. This exploitation will be carried out by PT personnel and will last several years, aiming at increasing the students' knowledge in the CFD field.

The knowledge acquired by PT employees will be useful to increase the quality of the Institution research, and this will lead to the capability of facing larger types of research projects, both with and without dedicated budget. However, no specific IPR measures have to be taken.

**Sub Project A3.** With the necessity to build up a new flexible engine management system for the SP A3 engine a standard – especially concerning the modular arrangement of functionalities – has been established at FEV. Further development projects with similar scope of work will benefit from that.

Due to time and cost intensive engine test bench measurements it is to expect that in the near future the development support by computational simulation will increase. Within INGAS subproject A3 the performed process simulation enabled a remarkable increase of knowledge concerning analysis of test bench data. Within further engine development projects simulation tools reasonably can be used in preposition also concerning reduction of the extent of measurements.

### 3. Report on societal implications

Replies to the following questions will assist the Commission to obtain statistics and indicators on societal and socio-economic issues addressed by projects. The questions are arranged in a number of key themes. As well as producing certain statistics, the replies will also help identify those projects that have shown a real engagement with wider societal issues, and thereby identify interesting approaches to these issues and best practices. The replies for individual projects will not be made public.

<b>A General Information</b> <i>(completed automatically when Grant Agreement number is entered.</i>	
Grant Agreement Number:	218447
Title of Project:	INGAS
Name and Title of Coordinator:	Massimo Ferrera, Dr.
<b>B Ethics</b>	
<p><b>1. Did your project undergo an Ethics Review (and/or Screening)?</b></p> <ul style="list-style-type: none"> <li>If Yes: have you described the progress of compliance with the relevant Ethics Review/Screening Requirements in the frame of the periodic/final project reports?</li> </ul> <p>Special Reminder: the progress of compliance with the Ethics Review/Screening Requirements should be described in the Period/Final Project Reports under the Section 3.2.2 'Work Progress and Achievements'</p>	No
<p><b>2. Please indicate whether your project involved any of the following issues (tick box) :</b></p> <p><b>RESEARCH ON HUMANS</b></p> <ul style="list-style-type: none"> <li>Did the project involve children?</li> <li>Did the project involve patients?</li> <li>Did the project involve persons not able to give consent?</li> <li>Did the project involve adult healthy volunteers?</li> <li>Did the project involve Human genetic material?</li> <li>Did the project involve Human biological samples?</li> <li>Did the project involve Human data collection?</li> </ul> <p><b>RESEARCH ON HUMAN EMBRYO/FOETUS</b></p> <ul style="list-style-type: none"> <li>Did the project involve Human Embryos?</li> <li>Did the project involve Human Foetal Tissue / Cells?</li> <li>Did the project involve Human Embryonic Stem Cells (hESCs)?</li> <li>Did the project on human Embryonic Stem Cells involve cells in culture?</li> <li>Did the project on human Embryonic Stem Cells involve the derivation of cells from Embryos?</li> </ul> <p><b>PRIVACY</b></p> <ul style="list-style-type: none"> <li>Did the project involve processing of genetic information or personal data (eg. health, sexual lifestyle, ethnicity, political opinion, religious or philosophical conviction)?</li> </ul>	No

• Did the project involve tracking the location or observation of people?	No
<b>RESEARCH ON ANIMALS</b>	
• Did the project involve research on animals?	No
• Were those animals transgenic small laboratory animals?	No
• Were those animals transgenic farm animals?	No
• Were those animals cloned farm animals?	No
• Were those animals non-human primates?	No
<b>RESEARCH INVOLVING DEVELOPING COUNTRIES</b>	
• Did the project involve the use of local resources (genetic, animal, plant etc)?	No
• Was the project of benefit to local community (capacity building, access to healthcare, education etc)?	No
<b>DUAL USE</b>	
• Research having direct military use	No
• Research having the potential for terrorist abuse	

### **C Workforce Statistics**

**3. Workforce statistics for the project: Please indicate in the table below the number of people who worked on the project (on a headcount basis).**

Type of Position	Number of Women	Number of Men
Scientific Coordinator		1
Work package leaders		15
Experienced researchers (i.e. PhD holders)	4	50
PhD Students		15
Other		

**4. How many additional researchers (in companies and universities) were recruited specifically for this project?**

Of which, indicate the number of men:	10
---------------------------------------	----

## D Gender Aspects

5. Did you carry out specific Gender Equality Actions under the project?  Yes  No

6. Which of the following actions did you carry out and how effective were they?

	Not at all effective	Very effective			
<input checked="" type="checkbox"/> Design and implement an equal opportunity policy	X	<input type="radio"/>	<input type="radio"/>	<input type="radio"/>	<input type="radio"/>
<input checked="" type="checkbox"/> Set targets to achieve a gender balance in the workforce	X	<input type="radio"/>	<input type="radio"/>	<input type="radio"/>	<input type="radio"/>
<input checked="" type="checkbox"/> Organise conferences and workshops on gender	X	<input type="radio"/>	<input type="radio"/>	<input type="radio"/>	<input type="radio"/>
<input checked="" type="checkbox"/> Actions to improve work-life balance	X	<input type="radio"/>	<input type="radio"/>	<input type="radio"/>	<input type="radio"/>
<input type="radio"/> Other: <input type="text"/>					

7. Was there a gender dimension associated with the research content – i.e. wherever people were the focus of the research as, for example, consumers, users, patients or in trials, was the issue of gender considered and addressed?

Yes- please specify

No

## E Synergies with Science Education

8. Did your project involve working with students and/or school pupils (e.g. open days, participation in science festivals and events, prizes/competitions or joint projects)?

Yes- please specify

No

9. Did the project generate any science education material (e.g. kits, websites, explanatory booklets, DVDs)?

Yes- please specify

No

## F Interdisciplinarity

10. Which disciplines (see list below) are involved in your project?

Main discipline<sup>9</sup>:

Associated discipline<sup>9</sup>:  |  Associated discipline<sup>9</sup>:

## G Engaging with Civil society and policy makers

11a Did your project engage with societal actors beyond the research community? (if 'No', go to Question 14)  Yes  No

11b If yes, did you engage with citizens (citizens' panels / juries) or organised civil society (NGOs, patients' groups etc.)?

- No
- Yes- in determining what research should be performed
- Yes - in implementing the research
- Yes, in communicating /disseminating / using the results of the project

<sup>9</sup> Insert number from list below (Frascati Manual).



<b>11c In doing so, did your project involve actors whose role is mainly to organise the dialogue with citizens and organised civil society (e.g. professional mediator; communication company, science museums)?</b>	<input type="radio"/> <input type="radio"/>	Yes No
<b>12. Did you engage with government / public bodies or policy makers (including international organisations)</b>		
<input checked="" type="radio"/> No <input type="radio"/> Yes- in framing the research agenda <input type="radio"/> Yes - in implementing the research agenda <input type="radio"/> Yes, in communicating /disseminating / using the results of the project		
<b>13a Will the project generate outputs (expertise or scientific advice) which could be used by policy makers?</b> <input type="radio"/> Yes – as a <b>primary</b> objective (please indicate areas below- multiple answers possible) <input checked="" type="radio"/> Yes – as a <b>secondary</b> objective (please indicate areas below - multiple answer possible) <input type="radio"/> No		
<b>13b If Yes, in which fields?</b>		
Agriculture Audiovisual and Media Budget Competition Consumers Culture Customs Development Economic and Monetary Affairs Education, Training, Youth Employment and Social Affairs	Energy Enlargement Enterprise Environment External Relations External Trade Fisheries and Maritime Affairs Food Safety Foreign and Security Policy Fraud Humanitarian aid	<input checked="" type="checkbox"/> Human rights Information Society Institutional affairs Internal Market Justice, freedom and security Public Health Regional Policy Research and Innovation Space Taxation Transport

<b>13c If Yes, at which level?</b>		
<input type="radio"/> Local / regional levels <input type="radio"/> National level <input checked="" type="radio"/> European level <input type="radio"/> International level		
<b>H Use and dissemination</b>		
<b>14. How many Articles were published/accepted for publication in peer-reviewed journals?</b>	<b>22</b>	
<b>To how many of these is open access<sup>10</sup> provided?</b>		
<b>How many of these are published in open access journals?</b>	<b>1</b>	
<b>How many of these are published in open repositories?</b>	<b>15</b>	
<b>To how many of these is open access not provided?</b>	<b>6</b>	
<b>Please check all applicable reasons for not providing open access:</b>		
<input type="checkbox"/> publisher's licensing agreement would not permit publishing in a repository <input checked="" type="checkbox"/> no suitable repository available <input type="checkbox"/> no suitable open access journal available <input type="checkbox"/> no funds available to publish in an open access journal <input type="checkbox"/> lack of time and resources <input type="checkbox"/> lack of information on open access <input type="checkbox"/> other <sup>11</sup> : .....		
<b>15. How many new patent applications ('priority filings') have been made?</b> <i>("Technologically unique": multiple applications for the same invention in different jurisdictions should be counted as just one application of grant).</i>	<b>1</b>	
<b>16. Indicate how many of the following Intellectual Property Rights were applied for (give number in each box).</b>	Trademark	-
	Registered design	-
	Other	-
<b>17. How many spin-off companies were created / are planned as a direct result of the project?</b>	<b>0</b>	
<i>Indicate the approximate number of additional jobs in these companies:</i>		
<b>18. Please indicate whether your project has a potential impact on employment, in comparison with the situation before your project:</b>		
<input type="checkbox"/> Increase in employment, or <input type="checkbox"/> Safeguard employment, or <input type="checkbox"/> Decrease in employment, <input checked="" type="checkbox"/> Difficult to estimate / not possible to quantify	<input type="checkbox"/> In small & medium-sized enterprises <input type="checkbox"/> In large companies <input type="checkbox"/> None of the above / not relevant to the project	
<b>19. For your project partnership please estimate the employment effect resulting directly from your participation in Full Time Equivalent (FTE = one person working fulltime for a year) jobs:</b>	<i>Indicate figure:</i>	
Difficult to estimate / not possible to quantify	X	

<sup>10</sup> Open Access is defined as free of charge access for anyone via Internet.

<sup>11</sup> For instance: classification for security project.

## I Media and Communication to the general public

20. As part of the project, were any of the beneficiaries professionals in communication or media relations?

Yes  No

21. As part of the project, have any beneficiaries received professional media / communication training / advice to improve communication with the general public?

Yes  No

22. Which of the following have been used to communicate information about your project to the general public, or have resulted from your project?

- |  |                                     |   |
|--|-------------------------------------|---|
| <input type="checkbox"/> Press Release                           | <input checked="" type="checkbox"/> | Coverage in specialist press  |
| <input type="checkbox"/> Media briefing                          | <input type="checkbox"/>            | Coverage in general (non-specialist) press                                      |
| <input type="checkbox"/> TV coverage / report                    | <input type="checkbox"/>            | Coverage in national press  |
| <input type="checkbox"/> Radio coverage / report                 | <input type="checkbox"/>            | Coverage in international press   |
| <input checked="" type="checkbox"/> Brochures / posters / flyers | <input checked="" type="checkbox"/> | Website for the general public / internet                                       |
| <input type="checkbox"/> DVD /Film /Multimedia                   | <input checked="" type="checkbox"/> | Event targeting general public (festival, conference, exhibition, science café) |

23. In which languages are the information products for the general public produced?

- |  |                                     |         |
|--|-------------------------------------|---------|
| <input type="checkbox"/> Language of the coordinator | <input checked="" type="checkbox"/> | English |
| <input type="checkbox"/> Other language(s)           |                                     |         |

**Question F-10:** Classification of Scientific Disciplines according to the Frascati Manual 2002 (Proposed Standard Practice for Surveys on Research and Experimental Development, OECD 2002):

### FIELDS OF SCIENCE AND TECHNOLOGY

#### 1. NATURAL SCIENCES

- 1.1 Mathematics and computer sciences [mathematics and other allied fields: computer sciences and other allied subjects (software development only; hardware development should be classified in the engineering fields)]
- 1.2 Physical sciences (astronomy and space sciences, physics and other allied subjects)
- 1.3 Chemical sciences (chemistry, other allied subjects)
- 1.4 Earth and related environmental sciences (geology, geophysics, mineralogy, physical geography and other geosciences, meteorology and other atmospheric sciences including climatic research, oceanography, vulcanology, palaeoecology, other allied sciences)
- 1.5 Biological sciences (biology, botany, bacteriology, microbiology, zoology, entomology, genetics, biochemistry, biophysics, other allied sciences, excluding clinical and veterinary sciences)

#### 2. ENGINEERING AND TECHNOLOGY

- 2.1 Civil engineering (architecture engineering, building science and engineering, construction engineering, municipal and structural engineering and other allied subjects)
- 2.2 Electrical engineering, electronics [electrical engineering, electronics, communication engineering and systems, computer engineering (hardware only) and other allied subjects]
- 2.3. Other engineering sciences (such as chemical, aeronautical and space, mechanical, metallurgical and materials engineering, and their specialised subdivisions; forest products; applied sciences such as geodesy, industrial chemistry, etc.; the science and technology of food production; specialised

technologies of interdisciplinary fields, e.g. systems analysis, metallurgy, mining, textile technology and other applied subjects)

### 3. MEDICAL SCIENCES

- 3.1 Basic medicine (anatomy, cytology, physiology, genetics, pharmacy, pharmacology, toxicology, immunology and immuno-haematology, clinical chemistry, clinical microbiology, pathology)
- 3.2 Clinical medicine (anaesthesiology, paediatrics, obstetrics and gynaecology, internal medicine, surgery, dentistry, neurology, psychiatry, radiology, therapeutics, otorhinolaryngology, ophthalmology)
- 3.3 Health sciences (public health services, social medicine, hygiene, nursing, epidemiology)

### 4. AGRICULTURAL SCIENCES

- 4.1 Agriculture, forestry, fisheries and allied sciences (agronomy, animal husbandry, fisheries, forestry, horticulture, other allied subjects)
- 4.2 Veterinary medicine

### 5. SOCIAL SCIENCES

- 5.1 Psychology
- 5.2 Economics
- 5.3 Educational sciences (education and training and other allied subjects)
- 5.4 Other social sciences [anthropology (social and cultural) and ethnology, demography, geography (human, economic and social), town and country planning, management, law, linguistics, political sciences, sociology, organisation and methods, miscellaneous social sciences and interdisciplinary, methodological and historical S1T activities relating to subjects in this group. Physical anthropology, physical geography and psychophysiology should normally be classified with the natural sciences].

### 6. HUMANITIES

- 6.1 History (history, prehistory and history, together with auxiliary historical disciplines such as archaeology, numismatics, palaeography, genealogy, etc.)
- 6.2 Languages and literature (ancient and modern)
- 6.3 Other humanities [philosophy (including the history of science and technology) arts, history of art, art criticism, painting, sculpture, musicology, dramatic art excluding artistic "research" of any kind, religion, theology, other fields and subjects pertaining to the humanities, methodological, historical and other S1T activities relating to the subjects in this group]