



GOOD ROUTE

IST-4-027873-STREP
Dangerous Goods Transportation Routing,
Monitoring and Enforcement

D10.3: Final Report

Publishable Part

Report Version: 2
Report Preparation Date: January 2009
Classification: Public
Contract Start Date: 01.01.2006
Duration: 36 months (Extension of 1 month, until M37, has been agreed upon the relevant amendment as of 21 November 2008)
Project Co-ordinator: CERTH/ITI
Partners: CERTH (ITI&HIT), CRF, IVECO, PTV, UPM, TID, GST, SITAF, COAT, USTUTT, ICCS, ELPA, FINRE, SIEMENS¹



Information Society
Technologies

Project funded by the European Community under the
“Information Society Technology” FP6 Programme (2002-
2006)

Thematic Priority: 2.4.12 eSafety-Cooperative Systems for Road
Transport

Project Co-ordinator:

Name: Dr. Dimitrios Tzovaras

Organisation: Centre for Research and Technology Hellas / Informatics and Telematics Institute (CERTH/ITI)

Address: 1st Km Thermi-Panorama Road, 57001 Thermi, Greece

Phone Numbers: +30-2310-487515

Fax Numbers: +30-2310-464164

E-mail: Dimitrios.Tzovaras@iti.gr

Project websites & other access points: <http://www.goodroute-eu.org/>

¹ As of the beginning of the year 2007, SIEMENS S.A. is not a Partner of the GOOD ROUTE Consortium and all activities under its responsibility have been allocated to other Partners of the Consortium having the relevant capacity. The aforementioned is depicted in the amended Description of Work as well as in all documents produced since then.

Table of Contents

Table of Contents	i
List of Figures	ii
List of Tables	iv
Abbreviation List	v
1. Publishable Final Activity Report	6
1.1. Project Execution	6
1.1.1. Project data.....	6
1.1.2. Project objectives.....	7
1.1.3. Overall relation of project to State of the Art	8
1.1.4. Specific objectives, work performed and end results	11
1.1.4.1. WP1: Traffic safety vs. mobility needs (CERTH/HIT) [Start: M1-End: M9]	11
1.1.4.2. WP2: Minimum Risk Route Guidance system (PTV) [Start: M6-End: M20]	20
1.1.4.3. WP3: On board Telematic System (CRF) [Start: M3-End: M22].....	39
1.1.4.4. WP4: Infrastructure Telematic System (TID) [Start: M3-End: M22].....	56
1.1.4.5. WP5: Enforcement System (UPM) [Start: M3-End: M21].....	66
1.1.4.6. WP6: Cooperative System Integration (IVECO) [Start: M6-End: M26].....	72
1.1.4.7. WP7: Pilot testing (FINRE) [Start: M1-End: M34].....	85
1.1.4.8. WP8: Guidelines, Training and standards (COAT) [Start: M1-End: M36]	91
1.1.4.9. WP9: Dissemination and exploitation (ICCS) [Start: M1-End: M35].....	94
1.1.4.10. WP10: Project management (CERTH/ITI) [Start: M1-End: M36].....	100
1.1.5. Impact on Industry and Research Sectors	101
1.1.5.1. General view.....	101
1.1.5.2. Insight in GOOD ROUTE expected impacts.....	103
1.1.5.3. GOOD ROUTE SWOT Analysis.....	110
1.1.6. Dissemination and Use	115
1.1.6.1. Project Communication material	115
1.1.6.2. Other Dissemination Actions.....	115
1.1.6.3. Exploitation Knowledge and its Use	119
Annex 1: Training Schemes for DG Drivers and Infrastructure Operators.....	135

List of Figures

Figure 1: Overall methodology followed for WP1.....	12
Figure 2: GOOD ROUTE ontological framework.....	18
Figure 3: GOOD ROUTE ontologies abstract.....	19
Figure 4: The DSS architecture.....	23
Figure 5: Relationships among risk models in GOOD ROUTE’s Quantitative Risk Analysis methodology.....	24
Figure 6: The GOOD ROUTE generalised Event Tree.....	25
Figure 7: An Event Tree example.....	25
Figure 9: The main window of the GOOD ROUTE Simulator showing the node and link property floating dialogs.....	27
Figure 10: Dialog box for defining a new transport.....	28
Figure 11: Dialog box for setting the economic cost parameters for a new transport.....	28
Figure 12: Dialog box for setting the risk-related cost parameters for a new transport.....	29
Figure 13: The lowest economic cost route.....	30
Figure 14: The lowest risk-related cost route.....	31
Figure 15: The lowest combined cost route.....	31
Figure 16: Conflict Resolution Module Architecture.....	32
Figure 17: Conflict Resolution Module Simulator.....	34
Figure 18: Output of the Conflict Resolution Module Simulator.....	34
Figure 19: DSS – Control Centre Architecture.....	35
Figure 21: GOOD ROUTE mobile client.....	36
Figure 22: GOOD ROUTE navigation application architecture.....	37
Figure 23: System Overview.....	40
Figure 24: Communication I2V.....	40
Figure 25: GOOD ROUTE telematic system architecture.....	41
Figure 26: Tractor architecture.....	43
Figure 27: In-Vehicle HMI architecture.....	45
Figure 28: Trailer architecture.....	46
Figure 29: Trailled emulator box.....	47
Figure 30: Baracoda RFID reader.....	47
Figure 31: GOOD ROUTE Client – maneuver list.....	50
Figure 32: GOOD ROUTE Client – Points of interest.....	51
Figure 33: GOOD ROUTE Client – traffic information.....	51
Figure 34: GOOD ROUTE Client – information of changed route.....	52
Figure 35: OBU DF internal modules.....	54
Figure 36: GOOD ROUTE OBU Data Fusion Simulator main menu.....	55
Figure 37: Overall Semantic Data framework of LSS.....	57
Figure 38: Logistics Support System within GOOD ROUTE.....	58
Figure 39: GOOD ROUTE system architecture backend overview.....	60
Figure 40: Screenshot from GOOD ROUTE portal – calculating a new route.....	62
Figure 41: Screenshot from GOOD ROUTE – calculating a new route.....	63
Figure 42: Screenshot from GOOD ROUTE – map & status view.....	64
Figure 43: Screenshot from GOOD ROUTE – infrastructure overview view.....	64

Figure 44: Screenshot from GOOD ROUTE – infrastructure – passage request view.....	65
Figure 45: Screenshot from GOOD ROUTE – infrastructure – infrastructure condition view.....	65
Figure 46: Enforcement System Overview.....	68
Figure 47: Enforcement System Architecture Overview.....	69
Figure 48: Police in the Enforcement System Network.....	69
Figure 49: Local Node internal Architecture.....	70
Figure 50: Enforcement System use cases.....	70
Figure 51: GOOD ROUTE General Context Diagram.....	73
Figure 52: GOOD ROUTE sub-systems.....	74
Figure 53: GOOD ROUTE architecture.....	75
Figure 55: GOOD ROUTE message Schema’s main structure.....	76
Figure 56: GOOD ROUTE communications architecture.....	77
Figure 57: Risk analysis process.....	79
Figure 58: GOOD ROUTE system overview and interfaces between the components.....	1
Figure 61: GOOD ROUTE IVECO Stralis.....	83
Figure 62: Tractor OBU integrated in truck cabin.....	83
Figure 63: Validation Approach of GOOD ROUTE (modified, following Zhang et al., 1998).....	86
Figure 65: Example route followed in Pilots.....	89
Figure 68: GOOD ROUTE deployment scenarios vs. evaluation criteria (expected impacts).....	95
Figure 69: Ranking of GOOD ROUTE evaluation criteria (expected impacts).....	96
Figure 70: GOOD ROUTE deployment scenarios overall ranking.....	96
Figure 71: Overview of GOOD ROUTE envisaged impacts according to Pilot participants interviewed.....	109
Figure 72: GOOD ROUTE value chain.....	120
Figure 73: GOOD ROUTE exploitation roadmap.....	124
Figure 74: Value chain for deployment scenario 1.....	126
Figure 75: Value chain for deployment scenario 2.....	127
Figure 76: Value chain for deployment scenario 3.....	128
Figure 66: GOOD ROUTE training curriculum for DG drivers.....	138
Figure 67: GOOD ROUTE training curriculum for Infrastructure Operators.....	139

List of Tables

Table 1: Comparison of the characteristics of GOOD ROUTE DSS in relation to Quantitative Risk Analysis Tools and Route Guidance Systems.....	10
Table 2: Interrelation of the GOOD ROUTE Use Cases and the “Profiles” of the GOOD ROUTE ontology.....	18
Table 3: User rights matrix.	61
Table 4: Participants per GOOD ROUTE pilot site.....	88
Table 5: Sensitivity Analysis Matrix.	97
Table 35: % of population present, outdoor and in road during day and night in an inhabited area.	104
Table 36: Fatalities and injuries in an inhabited urban and suburb area during day and night.	104
Table 8: Total distance, travel time, economic cost and risk for three alternative routes.	105
Table 9: Total distance, travel time, economic cost and risk for equipped and non-equipped DGV (allowed/not allowed to pass through the infrastructure).	106
Table 10: GOOD ROUTE dissemination activities.....	119
Table 11: GOOD ROUTE Exploitable plans.....	123

Abbreviation List



Term	Definition
A	Activity
ADAS	Advanced Driver Assistance Systems
ADR	Agreement concerning the international carriage of Dangerous Goods by Road
AES	Advanced Encryption Standard
CAN	Controller Area Networks
CBA	Cost Benefit Analysis
CC	Control Centre
CEA	Cost Effectiveness Analysis
CR	Conflict Resolution
CRM	Conflict Resolution Module
CRU	Conflict Resolution Unit
D	Deliverable
DFP	Data Fusion Platform
DGV	Dangerous Good Vehicle
DoW	Description of Work
DSRC	Dedicated Short Range Communications
DSS	Decision Support System
DTCO	Digital Tachograph
GIS	Geographic Information System
GPRS	General Packet Radio Services
GSM	Global System for Mobile communication
GUI	Graphical User Interface
GVW	Gross Vehicle Weight
HMI	Human Machine Interface
IVICS	In-vehicle Information and Communication Systems
LN	Local Node
LSS	Logistics Support System
M	Month
MIF	MapInfo files
OBU	On-board unit
OEM	Original equipment manufacturer
QCB	Quality Control Board
QMR	Quarterly Management Report
RFID	Radio Frequency Identification
SHP	ESRI shapefiles
UI	User Interface
UMTS	Universal Mobile Telecommunications System
V2V	Vehicle to Vehicle
WP	Workpackage
WSN	Wireless Sensor Network
WTH	Willingness to Have
WTP	Willingness to Pay

1. Publishable Final Activity Report

1.1. Project Execution

1.1.1. Project data

The following table summarises the GOOD ROUTE project data:

Project acronym	GOOD ROUTE				 
Contract Number	IST-4-027873-STREP				
Date of start	01 January 2006		Duration	36 months (37 months including one month extension)	
Coordinator details	Name: Dimitrios Tzovaras Organisation: CERTH/ITI Address: 1 st Km Themi-Panorama Road, 57001 Themi, Greece Tel/Fax: +30-2310-487515/ +30-2310-464164 E-mail: Dimitrios.Tzovaras@iti.gr				
Consortium	Participant name	Short name	Country		
	Centre for Research and Technology Hellas/ <i>Informatics and Telematics Institute</i>	CERTH/ITI	EL		
	Centre for Research and Technology Hellas/ <i>Hellenic Institute of Transport</i>	CERTH/HIT	EL		
	Centro Ricerche Fiat	CRF	IT		
	IVECO	IVECO	IT		
	Planung Transport Verkehr AG	PTV	DE		
	<i>SIEMENS S.A.²</i>	<i>SIEMENS</i>	<i>ES</i>		
	Universidad Politécnica de Madrid/ Life Supporting Technologies	UPM/LST	ES		
	Telefónica I+D	TID	ES		
	Gotthardstrassentunnel	GST	CH		
	Società Italiana per il Traforo Autostradale del Frejus	SITAF	IT		
	Center of Applied Technologies	COAT	CH		
	University of Stuttgart	USTUTT	DE		
	Institute of Communications and Computer Systems	ICCS	EL		
	Automobile and Touristic Club of Greece	ELPA	EL		
Finnish Road Enterprise	FINRE	FI			

² As of the beginning of the year 2007, SIEMENS S.A. is not a Partner of the GOOD ROUTE Consortium and all activities under its responsibility have been allocated to other Partners of the Consortium having the relevant capacity. The aforementioned is depicted in the amended Description of Work as well as in the current document.

Web site	www.goodroute-eu.org
----------	--

1.1.2. Project objectives

GOOD ROUTE, funded in terms of the 6th European Framework, aimed to develop a cooperative system for dangerous goods vehicle routing, monitoring, re-routing (in case of need), enforcement and driver support, based upon dynamic, real time data, aiming to minimise the Societal Risks related to their movements, while still generating the most cost efficient solution for all actors involved.

GOOD ROUTE has approached this aim, through its main objectives, which were to:

- Analyse dangerous goods accidents and needs of the dangerous goods companies, transporters, drivers, recipient clients, transport infrastructure owners, authorities, etc., as well as the best practises followed so far, for the specification of an integrated, cost-efficient, fair and modular system.
- Develop an ontological framework, which will classify and correlate the dangerous cargo, vehicle types and road infrastructure elements, to automatically permit or re-route specific dangerous good vehicles through specific road infrastructures (i.e. tunnels, long bridges, etc.).
- Develop a collaborative platform, able to gather and process in real time vehicle, cargo and environmental data (road status, unexpected obstacles, weather conditions, population density) as input to an optimal routing and route guidance system.
- Develop a minimum risk guidance system, that is able to route and re-route dangerous goods vehicles, taking into account individual and societal risk (based upon the collaborative platform based dynamic data), as well as conflict resolution and equity schemes.
- Develop Control Centre algorithms that will deal with movements of all participating dangerous goods vehicles within a certain geographical area, provide the necessary traffic and environmental data to them and inform in real time their logistic chain for any unscheduled re-routing required.
- Develop an on-board automatic data retrieval and storage system, to monitor key dangerous goods vehicle parameters (actual vs. planned route, speed, weight per axle, etc.), able to supply it to local nodes (i.e. police car at toll station or before tunnel/bridge, etc.), for enforcement purposes.
- Develop optimal user interfaces for both the drivers of the dangerous goods vehicle and the control centre operators, to provide them with appropriate information and/or warnings, without adversely affecting their workload or causing unnecessary behavioural adaptations.
- Integrate all functions in a prototype vehicle and test them in three Pilot sites, across Europe, to evaluate their reliability, usability, successfulness, cost efficiency and thus estimate their potential safety impact and viability.

- Involve all key actors in the dangerous goods transportation chain, as well as OEMs and sensor suppliers in order to result in a viable business strategy for wide and quick diffusion of the system.

1.1.3. Overall relation of project to State of the Art

The GOOD ROUTE project, in order to identify the needs and the most applicable Use Cases for the intended system, has taken into consideration a series of accident data sources which deal with the DG transportation in national, European and International level (i.e. FARS, MHIDAS, BP, GUNDI databases, INFORMED reported studies, etc.). It has managed to re-classify the available data in a way that enabled the identification of those conditional parameters that are considered significant for the GOOD ROUTE system implementation and evaluation, creating in this way a knowledge database around accidents and relevant information for the accidents and the status of traffic safety in the DG haulage sector. In addition, through the surveys and the workshops that were realised, it achieved to go one step further and detect the specific needs of all actors involved in the DG transportation chain, with regard to systems like GOOD ROUTE. The Use Cases identified is the most significant outcome of this work and can be used as a reference for other systems and for further research.

On the other hand, existing classification systems that support the current transportation schemes all around Europe, most of them ADR-based, but applied in a very specific way (according to local infrastructures and regulations requirements), have been investigated. The ontology of A1.5 (included in D1.1) is considered to be the most innovative outcome of WP1, since there is no relevant ontology known, which addresses the special conditions existing in DG transportation and has classified a series of info about the driver, the cargo, the company, the environmental conditions, the vehicle and the logistic chain, so that the needs of all interested actors (i.e. infrastructure, drivers, customers, companies, etc.) are addressed. Its main benefits lie in the fact that the ontology is open, easily interfaced and also amenable to further enrichment.

Furthermore, the Route Guidance System of GOOD ROUTE and its embedded DSS is the first and only (so far) system that optimizes routing by taking into account the risk associated with the road transport of dangerous goods in addition to the usual economic factors, such as time, distance and/or fuel consumed. Systems relevant to GOOD ROUTE can be separated into two broad categories, with no significant overlap between them. The first category encompasses systems dealing with Quantitative Risk Assessment whereas as the second deals with Vehicle Route Guidance and Optimization.

Quantitative Risk Assessment tools are based on a set of procedures, aimed at the quantitative assessment of the risks connected with processing, storage and transportation of dangerous substances in industrial areas. The risk quantification procedure is developed through the evaluation, for all risk sources, of the accidents occurrence frequency and of the magnitude of casualties caused by such events. Such tools include integrated modules for visualization, geospatial analysis, statistical analysis, human health risk assessment, ecological risk assessment, cost/benefit analysis, sampling design, and decision analysis. The main objective of all Quantitative Risk Assessment Systems is the location planning of industrial installations and/or of static transportation routes, by taking into account economic and societal factors (e.g. safety).

Vehicle Route Guidance and Optimization is a quickly expanding field, that uses the latest advances in telematics and computing to combine real time location information with detailed knowledge of terrains, in order to provide detailed routing instructions to vehicles on the road. All commercial fleet management systems offer a core of common features, such as:

- Multiple commodity, multiple vehicle routing optimization, that takes into account delivery time windows. Parameters optimized are of a financial nature, such as fuel cost or time, distance, etc.
- Integration with enterprise logistics systems.
- Wireless, real time (satellite and mobile carrier based) monitoring, and control of vehicles to various extents.
- Real time re-routing capabilities in the case of unforeseen events or changes in business requirements.
- Logging of vehicle status.
- Advanced systems, that offer a “hazmat” routing option, that takes into account relevant accessibility regulations and restrictions for the different classes of transported goods when doing routing optimization.

From the analysis of available offerings in both sectors it has been made clear that existing Quantitative Risk Assessment tools do not include facilities for dynamic vehicle routing, whereas Route Guidance systems do not take into account transport risk related factors.

The DSS of GOOD ROUTE is a system that integrates and builds on the most recent research efforts, combining methodologies from the area of Quantitative Risk Assessment and Vehicle Routing Optimization under real time conditions and local information. Even though existing systems overlap with particular areas covered by GOOD ROUTE and most of the relevant technologies and know-how are available, the integrated functionality offered by the GOOD ROUTE DSS is truly unique and novel. The following table presents a comparison of the characteristics of GOOD ROUTE DSS in relation to existing systems.

Characteristic	GoodRoute DSS	Quantitative Risk Analysis Tools	Route Guidance Systems
GIS back-end	✓	✓	✓
Quantitative Risk Assessment	✓	✓	
Evaluation of Risk measures (Individual & societal risks, F/N curves etc.)	✓	✓	
Vehicle Routing Optimization	✓		✓
Minimum Risk Routing	✓		
Use of real time traffic data	✓		✓
Use of local road characteristics	✓		✓

Use of local weather statistical	✓	✓	
Use of real time weather data	✓		
Consideration of broader needs of society	✓	✓	

Table 1: Comparison of the characteristics of GOOD ROUTE DSS in relation to Quantitative Risk Analysis Tools and Route Guidance Systems.

Even though there are significant challenges to be met before the system envisaged by GOOD ROUTE can become implemented to its fullest extent, significant gains can be expected from even an incomplete initial realization, thereby making the existence of a critical market mass for profitable implementation unnecessary. Challenges to be overcome relate mostly to the lack of detailed data from which accurate Quantitative Risk Assessment calculations can be made. However, even when using data with low time and space granularity, useful decisions can be made with regard to the routing of DGVs. Another significant challenge, that is being currently overcome, is the necessity of performing the numerically very intensive calculations, related to the calculation of transport risks over an entire road network in real or almost real time.

Considering the given total lack of commercial systems similar to GOOD ROUTE, in combination with the vigorous research interest apparent in the recent literature and the obvious benefits to society, it becomes clear that there should be significant commercialization opportunities for the GOOD ROUTE DSS and Route Guidance system. However, much concerted work remains to be done in terms of building the necessary information infrastructure, by the private as well as by the public sector, for sustainable real world implementation. The effort is certainly worthwhile, given the opportunities involved.

Another important module that GOOD ROUTE developed is the one dedicated to enforcement. Studies performed in the EU Member States showed that good enforcement practices could avoid many road fatalities resulting from speeding, not wearing seat belts or driving while intoxicated; moreover non compliance with rules relating to professional road transport activities, such as driving and resting times or weight and dimensions, for trucks and buses, is an important cause of fatal accident.

According to the Directive 2006/22/EC on social legislation relating to “Road transport activities”, the introduction of digital tachographs (DTCO) has become mandatory in all EU Member States commercial vehicles. The Directive defines checks to be undertaken, resting times and the proper operation of the tachograph and associated equipment. Some constraints have been introduced on storage duty of diagram charts in the vehicle, manual recordings and printout and their safekeeping period has been prolonged. Drivers, on request, must be able to present diagram charts, manual recordings and printouts for the current week plus the preceding 15 days.

EU Member States are currently planning legal regulations making DTCO remote data download mandatory, to achieve driver card and mass memory data on a regular basis.

The GOOD ROUTE project refers in particular to vehicles transporting goods that, in case of accident are dangerous for the environment and people health. The enforcement module developed within the project is connected to DTCO and anticipates the capability to transmit through wireless communication links driver and vehicle information to control centres and infrastructure nodes.

1.1.4. Specific objectives, work performed and end results

1.1.4.1. *WP1: Traffic safety vs. mobility needs (CERTH/HIT) [Start: M1-End: M9]*

Objectives

- To identify through a thorough accident analysis, bibliographical survey, experts and drivers opinion capture, the key drivers, cargo, infrastructure and environmental factors that may endanger the security and safety of a dangerous goods vehicle.
- To derive to priority application scenarios for each of the above environments for the GOOD ROUTE system.
- To map dangerous goods classes and sub-classes (according to ADR), vehicle types and cargo levels (empty, full, intermediate levels) to the infrastructure characteristics, safety equipment and limitations; creating a joint classification and ontologies.

Activities

- A1.1 Accident analysis of dangerous goods transport (CERTH/HIT)
- A1.2 Expert opinion collection (ELPA)
- A1.3 Driver comfort and work hours related needs (COAT)
- A1.4 Priority application scenarios (CERTH/HIT)
- A1.5 Dangerous goods classification and ontologies (CERTH/HIT)

Work performed and end results

WP1 has been concluded during the first year of the project and all work held in its context is reported in the context of D1.1: “Scenarios of use and dangerous goods ontological framework”.

The methodology followed for the work held in WP1 is shown in the following figure.

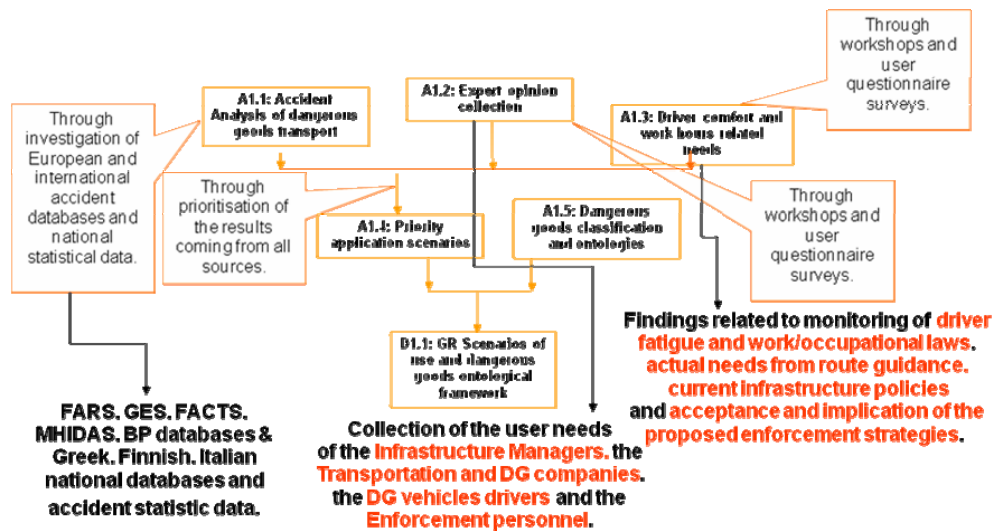

Figure 1: Overall methodology followed for WP1.

A detailed accident analysis has been executed. FARS, FACTS, GES, MHIDAS and BP most recent accident records, as well as other national data (provided by GOOD ROUTE Partners), have been investigated and quantifiable results have emerged for each conditional parameter that was considered significant for the GOOD ROUTE application scenarios. In short the following accident records/cases were investigated within the framework of the analysis:

- GES Accident Database: 174 accidents reported in 2004 with regard to DG vehicles.
- FARS Accident Database: The raw data of 196 cases reported in 2004 with regard to DG vehicles.
- BP Road Trend Database: 161 Road Accidents from January 2001 to February 2003 with regard to DG vehicles.
- FACTS Accident Database: 50 road transport accidents from 2004.
- MHIDAS Accident Database: 100 road transport accidents randomly selected from 2004.
- GUNDI Database: 513 road transport accidents from 1991 until beginning of 2007.
- National data: 25 road accidents related to DG vehicles from the Greek accident database records for 2004, Finnish accident data from 2004 (3486 personal injury accidents) and accidents distribution for years 1999-2004 and presentation of statistics on 318 dangerous goods vehicle incidents coming from the ISTAT database of the Polytechnico of Torino for the years 2003 and 2004.
- Short summation on fatigue-related accidents status (on international level) for DG vehicles and trucks.

The parameters identified as interesting for the accident analysis execution are the following:

-
- Country.
 - Total Number of DG vehicles/ trucks accidents (incl.fatal, injury, damage).
 - Number of DG vehicles/trucks fatal accidents.
 - Number of injury accidents (including fatal) with DG vehicles/trucks.
 - Visibility conditions.
 - Road surface condition.
 - Light conditions.
 - Roadway Alignment.
 - Special infrastructure.
 - Road type.
 - Traffic density.
 - Type of vehicle.
 - Speed of DG vehicle/truck before crash.
 - Collision type.
 - Maneuver type.
 - Cargo type transported.
 - Hazardous Cargo release.
 - Accidents/incidents causes.

All above are parameterised per type of vehicle (Light truck; Heavy truck; Articulated truck; Light tank truck; Heavy tank truck; Articulated tank truck). For the classification per the above types of vehicles, the classification system of GES and FARS databases has been followed.

However, not in all cases, the above accident data were available. On the other hand, there have been cases, where more specific parameters, as for example, weather conditions, time of day, time of year, type of area, etc., were reported.

In parallel to the accident analysis, a user needs survey was executed through workshops and interview surveys. The user needs of the Infrastructure Managers, the Transportation and DG companies, the DG vehicles drivers and the Enforcement personnel regarding the functionalities GOOD ROUTE aimed to address, was the objective of the user needs surveys and the workshops conducted.

There were two workshops conducted in the context of A1.2: “Expert opinion collection”, namely the Pan-European (held in 08/09/06) and the Greek Workshop (13/04/06), as well as a series of interview surveys in the GOOD ROUTE Pilot sites (Finland, Italy and Switzerland), as follows:

- ⇒ Greek survey and workshop (Athens; ELPA offices; 13/04/06): 14 filled-in questionnaires by key Greek stakeholders in the transportation sector and the DG haulage sector.
- ⇒ Italian survey: 10 filled-in questionnaires by DG drivers, coming from different companies and 2 from Police Officers. The infrastructure point of view was provided by SITAF personnel.
- ⇒ Finnish survey: 6 filled-in questionnaires by executive managers in a DG owner company and a transportation company and 10 from DG drivers.

⇒ Finally, the GOOD ROUTE Pan-European workshop, held on 08/09/06 in Stuttgart (USTUTT offices), entitled “Taking the safest route; The GOOD ROUTE initiative”, was the first workshop organized within the framework of GOOD ROUTE project and contributed significantly to the public awareness about GOOD ROUTE, whereas it also helped with the identification of some major needs across Europe from all points of view (infrastructure, transportation companies, Fire Brigade and Police, drivers, etc.). The workshop had 33 participants and the full details of the event have been uploaded in the project web site “<http://www.goodroute-eu.org>”, where the final minutes and the presentations of the workshop can also be found.

An additional survey has been conducted in the context of A1.3: “Driver comfort and work hours related needs”, with regard to driver fatigue and work/occupational laws, actual needs and details from route guidance, current infrastructure policies and alternatives and acceptance and implication of the proposed enforcement strategies. Within this survey, 7 Swiss drivers were interviewed, whereas in Finland 2 group interviews were conducted, within the framework of which, 3 executive managers in the transportation sector and 11 drivers were interviewed.

The results coming from the accident analyses, the user needs surveys and the workshops (Greek and Pan-European) have been prioritised by 5 internal experts upon the following three levels:

- 1: High Priority
- 2: Medium Priority
- 3: Low Priority

The “High” and “Medium” indices have led to the identification of the priority conditional parameters for the GOOD ROUTE use cases.

The priority conditional parameters for GOOD ROUTE are the following:

Visibility conditions

- 1: High visibility conditions
- 2: Medium visibility conditions

Road surface conditions

- 1: Dry road surface
- 2: Wet road surface

Light conditions

- 1: Daylight conditions
- 2: Lighted roads (either during night or not)

Roadway alignment

- 1: Straight roads (no intersection)
- 2: Intersections/curves

Type of cargo

- 1: Liquid fuel (transport fuel)

2: Gas

Travel speed related to accidents

1: 51-80km/h

2: 0-50km/h

Vehicle manoeuvre

1: "Going straight"

2: "Negotiating a curve" (11.6%) & "Turning (left)"

Type of road/type of location

1: Highways/non-residential areas

2: Rural roads/residential areas + tunnels, bridges ferry lines and harbors, peri-urban motorways of big cities, new roads of high speed, entry points to a state and especially to the EC

3: Urban roads

Weather conditions

1: Good weather conditions (clear and sunny)

2: Clouded/Mist/Rain

Time of day

1: 13:00-18:00

2: 00:00-06:00

Time of week

1:Weekends

2: Monday

Time of year

County dependent. All year times.

Vehicle type

1: Articulated tank trucks

2: Tank trucks (road tankers)

The conditional parameters have been instantiated in D7.1: "Final Pilot Plans" per scenario and site.

The values attached as more critical ones at each identified conditional parameters have been also taken into account for the Decision Support system algorithms formulation. However, some of the above values, such as "Time of Day" or "Time of Week" have been instantiated per Pilot Site, taking into consideration the local restrictions and special cases, leading to the identification of the expert rules, which have been used as a feedback for the DSS and have been dealt in A2.1: "Extraction of expert knowledge rules".

In addition to the above conditional parameters, a series of items and needs were identified with regard to the GOOD ROUTE routing, re-routing, emergency and enforcement functionalities, which were very much considered in the formulation of the Use Cases (Chapter 5 of D1.1).

Nine priority GOOD ROUTE use cases have been identified as follows:

- UC1: “Passport”
- UC2: “Route guidance”
- UC3: “Environmental-related re-routing”
- UC4: “Business-related re-routing”
- UC5: “Enforcement”
- UC6: “Logistics”
- UC7: “Emergency”
- UC8: “C2C communication”
- UC9: “Critical info”

The GOOD ROUTE Use Cases have been described in Chapter 6 of D1.1 across the following fields:

- *Context of use.* This includes the description of the main use case, i.e. routing, re-routing, etc.
- *Primary actor.* This is the actor who initiates the use case and may be the driver, the infrastructure, the company, the Police, etc.
- *Input (trigger).* This is the first action/request that is provided by one actor.
- *Output.* It is the feedback and the reaction of the system to the *Input (trigger)*.
- *Main success scenario(s).* This includes the upper level description of the Use Case, taken that the system will operate as expected.
- *Connected UCs or extensions.* This refers to any extension or connectivity of the current UC to other UCs.
- *Indicative scenarios of use.* A number of indicative scenarios (envisaged from the *primary actor* aspect) are outlined.

Use Case 1: “Passport” is extracted from D1.1 to serve as an example:

UC1: “Passport”

- *Context of use.* The driver or the company, according to the initially defined route, notifies the system of estimated time of passage through an infrastructure and books the passage through a relevant request.
- *Primary actor.* Driver or company.
- *Input (trigger).* The user (driver or company) provides the vehicle and cargo data, notifies the system of the estimated time of arrival of the specific vehicle at a specific infrastructure and makes a request for passage approval and booking.
- *Output.* The system returns the answer to the user (driver or company) with regard to allowance of passage (potentially with a receipt of booking. For alternative cases, please see at the connected UCs and extensions.

- *Main success scenario(s).*
 - ⇒ **Step 1:** *The user makes a request for the permission of passage to the infrastructure at least 24 hours before the estimated time of arrival at the infrastructure. Vehicle and load info are provided to the infrastructure in the context of the request.*
 - ⇒ **Step 2:** *The system provides the permission of passage on behalf of the infrastructure or notifies for non-feasibility of booking (see connected UCs and extensions) within a time horizon of 15 minutes from the time of request.*
 - ⇒ **Step 3:** *When vehicle arrives at the infrastructure, it is allowed to pass by priority, even in traffic congestion case. The time-horizon of allowed passage is 30-40 minutes around the declared/booked time of arrival.*
- *Connected UCs and extensions. An extension of the UC is the booking of special transits (i.e. big caravans, big amounts of loads or cargo, associated with high level of risk, etc.), where a permission for “special passage” is required and the request for passage booking should be made at least 3 days before by the user. In case of non-feasibility of passage at the requested time, the system has two options (after user consent): either identifies another time of passage through the specific infrastructure, which is close to the initially requested one, or, if this is not possible at all, due to many reasons, such as big expected traffic, business reasons, etc., it initiates the procedure for re-routing (see UC’s 3,4). Moreover, there is a connection to UC9. If the driver is notified for incidents ahead that will cause delays or will totally hinder him from passing through the specific infrastructure, then a relevant notification should be done from the driver (or the system automatically, when receiving the relevant info).*
- *Indicative scenario(s) of use.*
 - ⇒ *“Vehicle X³ (if the user is the company) or I (if the user is the vehicle) need/s to pass the Y tunnel around 19:00pm tomorrow”.*

Finally, the ontological framework of the project was developed and the full ontology is provided in Annex 5 of D1.1. The main fields of the ontology address the driver, the vehicle, the cargo and the environmental conditions. In the context of these fields, the itineraries, the company data and all significant logistics items have been considered. The GOOD ROUTE ontology has been developed in XML schemas and is open to other systems, in order to be interfaced and interface other existing ontological frameworks related to DG vehicles transportation.

The following figure represents in short the GOOD ROUTE ontological framework concept.

³ X refers to the ID of the vehicle and the load.

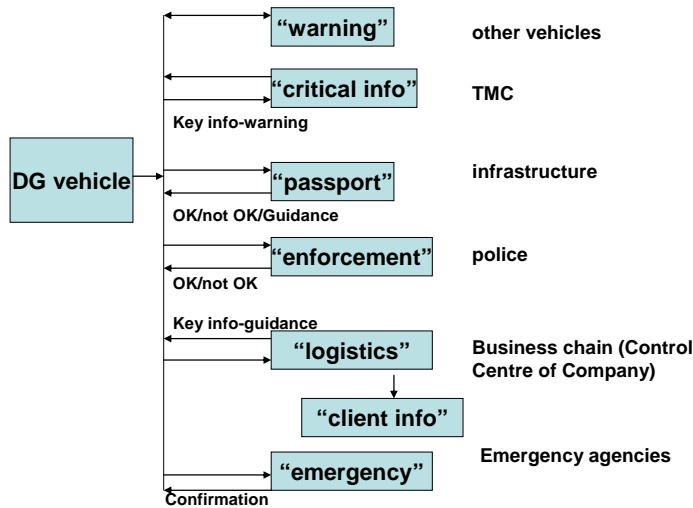

Figure 2: GOOD ROUTE ontological framework.

The Use Cases of the system, as described in Chapter 6 of D1.1, are depicted in the above “Profiles”. The interrelation of the GOOD ROUTE Use Cases and the “Profiles” of the GOOD ROUTE ontology is presented in the following table.

Ontological “profile”	GOOD ROUTE Use Case
“Warning”	UC8: “C2C communication”
“Critical info”	UC9: “Critical info”
“Passport”	UC1: “Passport”
“Enforcement”	UC5: “Enforcement”
“Logistics”	UC2: “Route guidance”; UC3: “Environmental-related routing”; UC4: “Business-related re-routing”; UC6: “Logistics”
“Emergency”	UC7: “Emergency”

Table 2: Interrelation of the GOOD ROUTE Use Cases and the “Profiles” of the GOOD ROUTE ontology.

An abstract of the GOOD ROUTE ontology is provided below:

ONTOLOGY (VEHICLE)										
Information need	Information element	Conditions/ Attribute	Value metrics	Value (blank)	Value threshold	From whom	To whom	Profile	Timing	
							agencies		upon accident/incident occurrence	
2.19 Travel/itinerary	2.19.1 Travel origin latitude position	WGS84 Geodecimal			NA	DC vehicle	Infrastructure	"Passport"	24 hours before the time of arrival	
						DC vehicle	Business Chain	"Logistics"	Upon request	
	2.19.2 Travel destination latitude position	WGS84 Geodecimal			NA	DC vehicle	Infrastructure	"Passport"	24 hours before the time of arrival	
						DC vehicle	Business Chain	"Logistics"	Upon request	
	2.19.3 Type of destination	Text (Supply Depot, Gas station, etc.)				NA	DC vehicle	Infrastructure	"Passport"	24 hours before the time of arrival
							DC vehicle	Business Chain	"Logistics"	Upon request
2.19.4 Type of itinerary	Text (international trip, feeding itinerary, distribution itinerary, etc.)				NA	DC vehicle	Infrastructure	"Passport"	24 hours before the time of arrival	
						DC vehicle	Business Chain	"Logistics"	Upon request	
2.19.5 Time of trip initialisation			GPS		NA	DC vehicle	Infrastructure	"Passport"	24 hours before the	

Figure 3: GOOD ROUTE ontologies abstract.

An updated version of D1.1 was released in the 2nd year, including some updates in the accident analyses (GUNDI database analysis has been incorporated), whereas several updates of the ontology have been held until the end of the project, for the sake of compliance with the specifications and the architecture of the system.

1.1.4.2. WP2: Minimum Risk Route Guidance system (PTV) [Start: M6-End: M20]

Objectives

- To process static and dynamic data from in-vehicle and infrastructure sources, taking into account safety critical aspects, infrastructure capacity risk analysis algorithms, different social and business group demands and conflict resolution between enterprises, to provide minimum risk and high efficiency dynamic routing and re-routing for dangerous goods trucks.

Activities

A2.1 Extraction of expert knowledge rules (CERTH/HIT)

A2.2 Individual risk calculation (CERTH/ITI)

A2.3 Societal risk calculation (CERTH/ITI)

A2.4 Conflict resolution and equity schemes (ITD)

A2.5 Overall risk estimation and decision support system development (CERTH/ITI)

A2.6 Simulation and optimisation for impact analysis, including other road users (CERTH/HIT)

A2.7 Minimum Risk Route Guidance System (PTV)

Work performed and end results

WP2 has been identified as a core work-package of GOOD ROUTE.

In the context of A2.1: “Extraction of expert knowledge rules” a series of interviews have been undertaken among companies in order to identify the business rules that are applicable at a company level concerning the logistics and routing of the dangerous goods vehicles. Two major DG transportation companies, namely SHELL and BP (Greek departments) have been interviewed as example case studies, in order to extract the basic business rules and principles applied in the routing of their vehicles.

In addition, the local rules of the GOOD ROUTE Pilot sites (FINRE, SITAF, GST) have been captured and are presented below.

According to the outcomes of this work, in general terms, the DG companies comply with the national legislation rules for the transportation of dangerous goods in the reference network. These rules concern the basic driver restrictions, safety standards, speed limits, etc. Even if there is no concrete National Reference network, the companies use the safer road network in terms of quality of infrastructure and accessibility in case of incidents.

On the other hand, each company has different approach in monitoring each of the vehicles, the set-up and the policy in terms of re-routing. However there is a clear view that re-routing procedures are basically due to traffic reasons and in scarce cases. Since the real-time communication between the driver and the companies is not established

through any telematic system (some pilot applications are held at the moment in BP), the re-routing procedure is available to the driver only at the subsequent stop.

There is a clear gap in this part of the logistics chain of the dangerous goods as well as the inflexibility in organising the chain at real time and on demand since all orders are scheduled a day before, with limited possibilities for alterations.

All retrieved local rules have been embedded as rules into the DSS. For example, the re-routing alternatives, as described in each Pilot site, constitute the most significant info for the Re-routing Use Case, since the system has to have embedded from which routes is allowed to select in case the main infrastructure passage is closed for any reason (national holiday, maintenance, other event). Of course, dynamic real time traffic, weather and other data are also to be taken into account, through the establishment with the corresponding TMC of the region. This would cover extraordinary events, which cannot be foreseen or extreme weather conditions (storms, etc.) that would not allow the passage through specific routes, etc.

Thus, if the optimum route (or re-route) selected by the DSS in the first place is one of the routes that are not allowed at specific days or hours, the time-related embedded local rules (which have been correlated to specific GIS data with regard to specific coordinates), will function as “flags” which will make the system to proceed automatically to the next optimum route. In a similar way, the parking and rest areas are used, whenever available. The system needs to know where is the closest resting area when the issued route includes stops (also applicable in the Passport Use Case or the re-routing due to Business Reasons Use Case). The working hours regulations in each region are also important, since, if violated, may fall under penalties for the specific region, thus the system needs to know in advance what is the maximum duration of the route that is permitted to issue.

Expert rules are provided as Annex B of D2.2: “Minimum Risk Route Guidance System” and have been embedded in the DSS, for its instantiation for each Pilot site in GOOD ROUTE.

The aforementioned Decision Support System (DSS) is the vital part of the GOOD ROUTE system. It is responsible for calculating the optimum route, which is either the lowest-cost route, the lowest-risk route, or a combination of the two. It calculates the optimum route for every requested dangerous goods transport by checking for conflicts regarding this route with the Conflict Resolution Module (CRM).

The DSS takes into account the individual and societal risk-related cost, in addition to the economic cost, and calculates the optimum route by eliminating the combination of them. The combined cost, which is eliminated, is the result of the linear combination of the economic and risk related cost, by the use of a weighting factor. The inputs to the system include the road network, population distribution data, real-time as well as statistical traffic and weather data, historical accident data, road characteristics, real-time vehicle and cargo status. These data are, whenever possible, time-dependent, with the day being divided into a certain number of time intervals, each of which corresponds to a different value of the time-dependent data.

The DSS calculates either the minimum risk, the minimum cost, or the minimum combined-cost route. The calculated route is then submitted to the Conflict Resolution

Module, which, having a complete view of the road network, the ongoing and the scheduled routes, it accepts it or rejects it. The DSS calculates an alternative route, avoiding the problematic parts of the road network in case the proposed route is rejected, i.e. because certain road segments have exceeded their DGV capacity. In case information is not available for some links capacity, it is moderated by means of a random number, using as input the road category of the link. However, this is static information that won't change so often.

The above process continues until the CRM finally accepts a proposed route. Thus, as it was described above, the DSS considers every DGV transport individually. In order to achieve its goal, it combines data from various sources, both static and real-time. The data that are used are the following:

The **Transportation Network Database**, which contains information about infrastructure and all possible routes. In fact, it is a Geographic Information System (GIS), consisting of nodes and links. The nodes are generally defined as geographical locations with at least two alternative routes for moving cargo. Links are road segments that directly connect two nodes. Every link has properties, such as road category, length, possible tolls, information about the operation hours of the link, etc. Waiting points can also be integrated into the Transportation Network, and be represented by links with the same starting and ending node.

The **Impact Area Database**, which contains information relevant to population distribution. The control area is divided into a number of polygon-shaped areas, with different population densities. The population density of each area may vary throughout the day, as people move from residential to work or recreation areas. Information about population “hotspots”, such as schools and hospitals is also available and taken into account.

The **Past Accident Database**, which is used in order to exploit general and specific causes of accidents, as well as severity of risk factors and indicators. In case past accident data do not exist for the particular road, relevant road type averages are used.

The **Real Time Data**, consisting of current and forecasted weather conditions, traffic conditions, vehicle and cargo properties (such as substance type, tank temperature and pressure, etc). In case of lack of some real time data, the corresponding static historical data are used.

The DSS consists of two parts, the Risk Estimation Module, which calculates the risk related cost that is associated to each segment of the road network, for the particular transport, and the Optimal Route Calculation Module, which produces the optimal route, that is to say the one with the lowest overall combined cost. The former provides the latter with the necessary data to proceed to the calculation.

An interesting feature of the DSS is its capability of handling time-dependent data, whenever they are available. A key concept of that capability is the “time interval”. The day is divided into a number of equally sized time intervals. The time-dependent data take so many different values throughout the day as the number of the time intervals per day is. The data that can be time-dependent are the travel times and the population distribution, reflecting the variable traffic loads and the population shifts throughout the day

The DSS was developed in C++ and has the form of a library that can be used by other modules. That library is wrapped in a web service that was developed in Managed C++,

and which forms the final state of the DSS. A standalone windows application was also developed, in order to test the DSS's operation during the development process. That application, the GoodRoute Simulator, wraps the DSS in a clear and efficient user interface, and can be used independently from the rest of the GOOD ROUTE system, for testing various scenarios and use cases where the DSS is involved.

The GOOD ROUTE Decision Support System consists of two modules, which are the Risk Estimation Module and the Optimum Route Calculation Module.

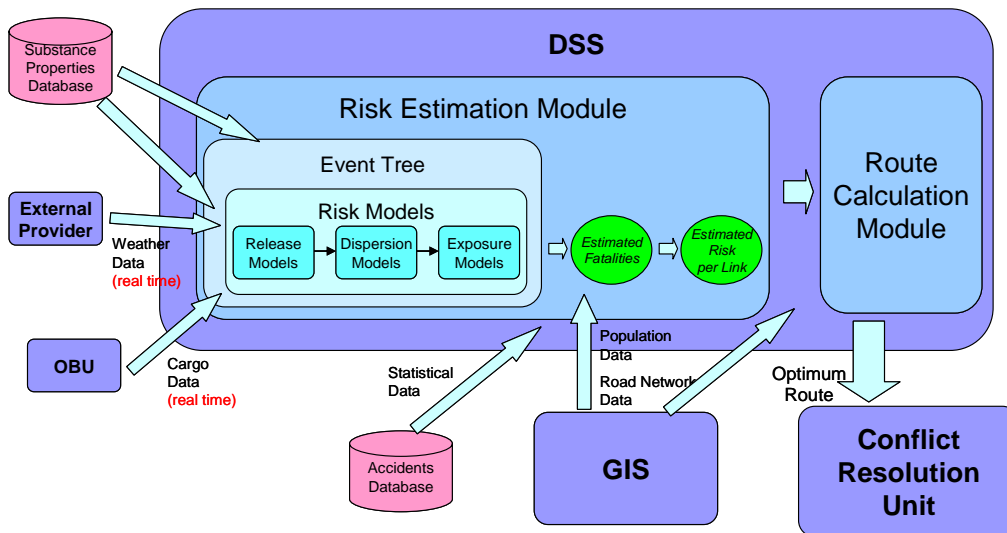

Figure 4: The DSS architecture.

The Risk Estimation Module calculates the individual and societal risks for every segment (link) of the road network. The road network consists of nodes and links, which are road segments between two nodes. What the Risk Estimation Module does, is applying a single risk-related cost value to every link of the road network for the particular dangerous goods transport, implementing the Risk Estimation Algorithms (through Event Tree analysis) that are fully covered in (D2.1 “Risk Estimation Algorithms”). The risk-related cost value is time-dependent, in other words it may change throughout the day as the various parameters that affect it (weather conditions, population density, etc.) also change.

The Optimal Route Calculation Module is responsible for providing the optimal route for the requested dangerous goods transport, taking into account the risk-related costs that were previously calculated by the Risk Estimation Module. What it really does is minimising the total combined cost of the route, finding the minimum combined cost route. With the term combined cost we mean the combination of the risk-related cost and the economic cost. An economic cost value is attached to every link of the road network, in addition to the risk-related cost value that has been calculated by the Risk Estimation Module. These two cost values are then combined into a combined cost value, using a weighting factor. The weighting factor is a float number between 0 and 1, and it can be easily changed through a dialog box (in the GOOD ROUTE Simulator application) or through the registry (in the GOOD ROUTE DSS web service). That

combined cost, which is of course time-dependent like the ones that it has resulted from, is minimised by the Optimal Route Calculation Module.

The calculated optimal route is submitted to the Conflict Resolution Module, which decides whether it will accept it or not. In case that the proposed route is rejected, because one or more road segments have exceeded their DGVs capacity, a new route is calculated and submitted. That process continues until a route is finally accepted.

The GOOD ROUTE Decision Support System (DSS) gets input from various sources through the Control Centre. These sources provide either static (i.e. statistical accident data) or real-time (i.e. weather conditions) data. All these data are used in the calculation of the optimal route.

The Risk Estimation Module utilises the Risk Estimation Algorithms that are covered in D2.1 (Risk Estimation Algorithms).

It assigns a single risk value, which reflects the risk of human fatalities, to each link of the Transportation Network, for every requested DGV transport. That value is, like almost every other aspect of the system, time-dependent. In other words, it is varying throughout the day. In order to calculate the above risk value, the Risk Estimation Module uses the methodology of Quantitative Risk Analysis. The following figure demonstrates the relationships among the various events that may occur following a DGV incident.

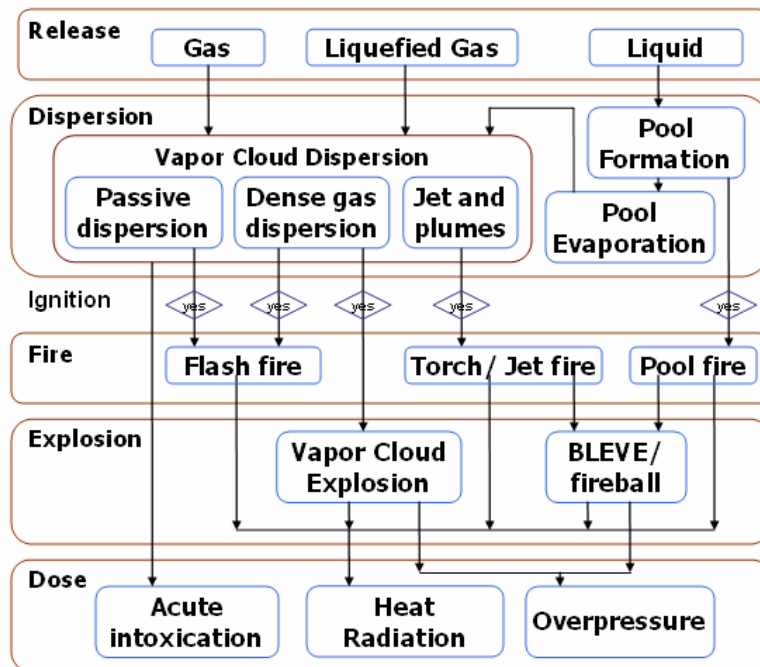

Figure 5: Relationships among risk models in GOOD ROUTE's Quantitative Risk Analysis methodology.

An Event Tree is constructed, organising the aforementioned possible undesired events in a hierarchical way. Each branch of the Event Tree corresponds to a possible chain of events and their associated probabilities (see following figures).

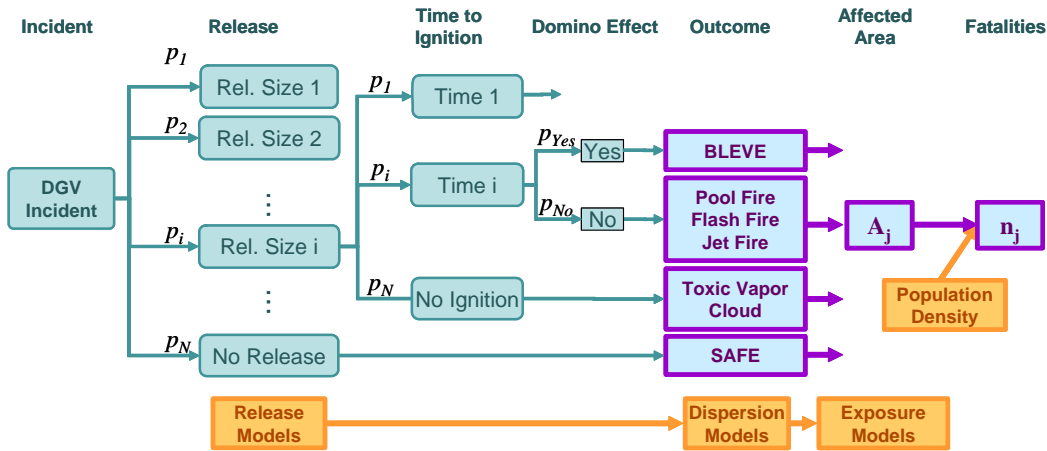

Figure 6: The GOOD ROUTE generalised Event Tree.

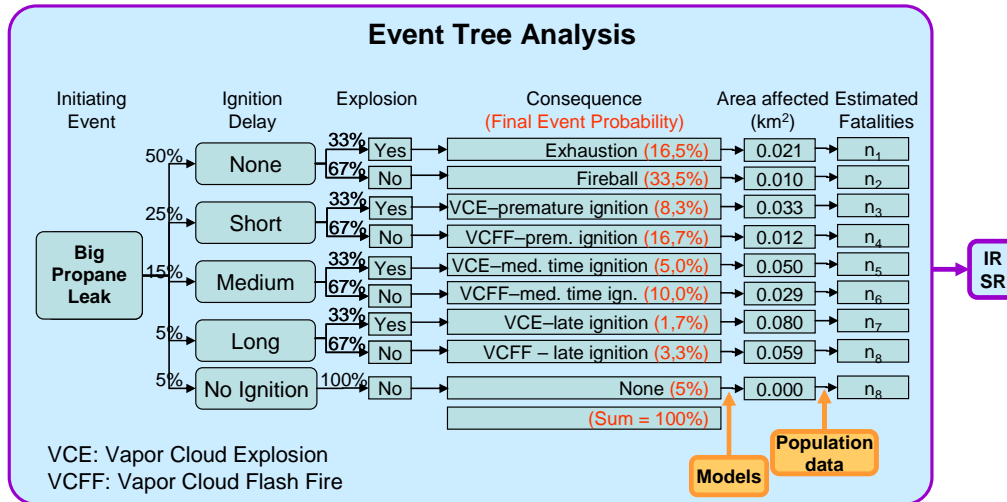

Figure 7: An Event Tree example.

At the next step, a sequence of Risk Models is associated to each leaf event of the Event Tree. Each model uses the output of the previous model as input. The above process results into an F/N curve (where F is the cumulative probability of N or more casualties), which represents the societal risk.

The DSS communicates with the other modules of the GOOD ROUTE System through web services. It acts even as a client (invoking other web services to get the necessary information) or as a server (receiving route requests).

The routing process starts with the Navigation Module (NM) requesting a new DGV transport request, by calling the respective DSS web service and passing all the respective parameters (source node, destination node, transport type, departure/arrival data, vehicle parameters, cargo parameters) to it.

The DSS then invokes other Web services if necessary, in order to gain real-time traffic and weather data.

After the route calculation, the DSS calls a Web service, exposed by the Conflict Resolution Module (CRM), in order to submit the proposed route.

...

The CRM's reply will be the approval or rejection of the route. In case of rejection, the IDs of the road segments that exceeded their capacity will be returned to the DSS, so as to calculate an alternative route by excluding them.

The three cooperating modules (the Decision Support System, the Conflict Resolution Module and the Navigation Module) have access to the same GIS data (concerning the road network, the nodes/links and their IDs), in order to properly communicate and understand each other.

The GOOD ROUTE Simulator is a Windows application that was built for simulating and testing purposes of the DSS. It has a clear, detailed and highly configurable user interface, and it is used mainly for testing purposes within the development process of the DSS. The DSS module is integrated into the application. However, it is currently being converted into a Web service form so as to be integrated with the other cooperating modules (the Conflict Resolution Module and the Navigation Module). The GOOD ROUTE Simulator applies the DSS algorithms on the GIS data (road network, population distribution), providing the optimal route(s) as an output. That output can be displayed on the screen and can also be stored in a file. The display of the network and population data, in addition to the proposed route(s) can be configured in several ways.

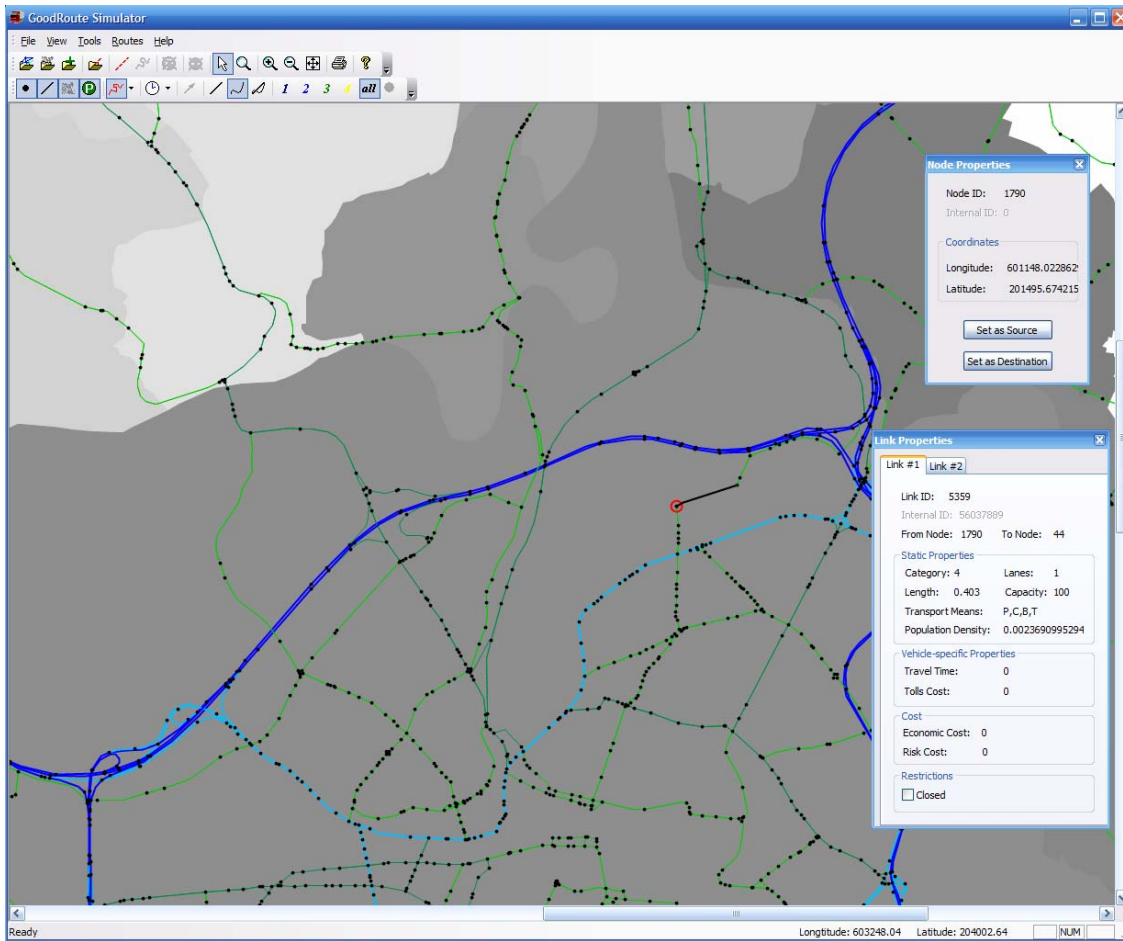

Figure 8: The main window of the GOOD ROUTE Simulator showing the node and link property floating dialogs.

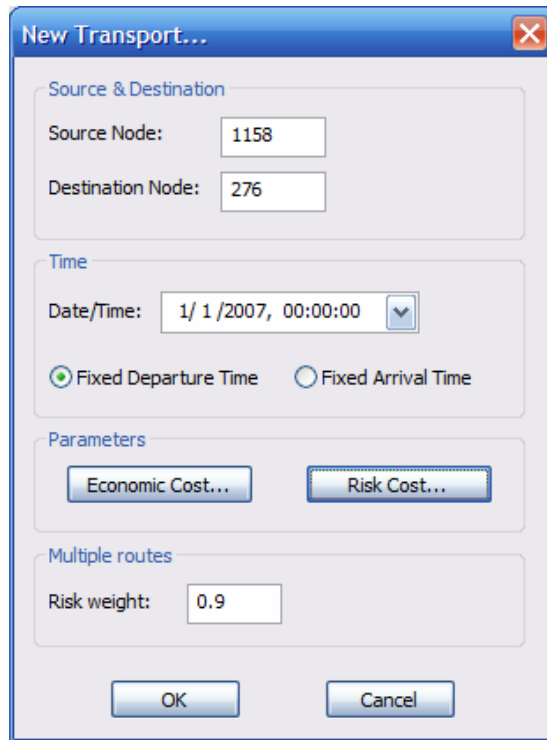

Figure 9: Dialog box for defining a new transport.

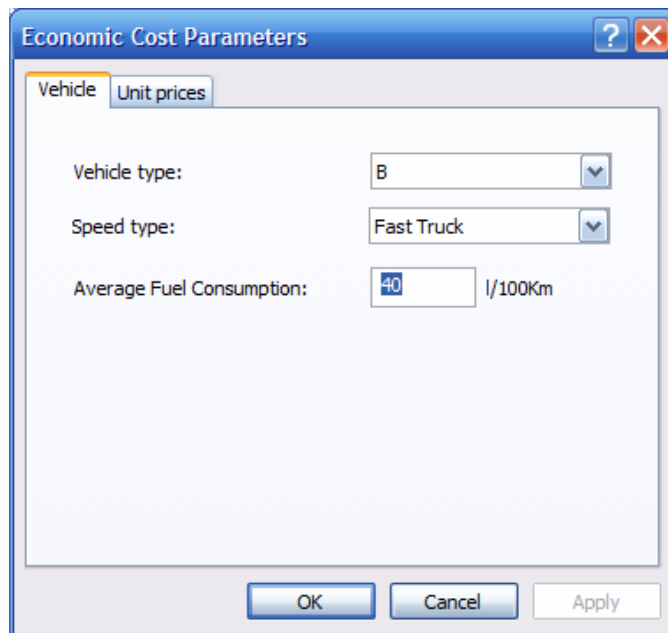

Figure 10: Dialog box for setting the economic cost parameters for a new transport.

Parameter	Value	Unit
Type:	Propane	
Specific heat constants:	1391.6, 9.7571, -0.05589E, 0.000126	
Liquid density constants:	220.4, 0.2753	
Vapour pressure constants:	59.078, -3492.6, -6.0669, 1.0919e-0, 2	
Latent heat of vaporization exponent:	0.38	
Heat of combustion:	46000000	J/Kg
Latent heat of vaporization at 1 Hv,0 and 1 Atm:	425930	J/Kg
Molecular weight:	0.044096	Kg/mol
Poisson ratio	1.13	
Boiling temperature	230.9	K
Boiling temperature	369.7	K
Temperature of flame:	2000	K
Melting temperature:	86	K
Liquid density:	510	Kg/m ³
Vapour Density (at Pv,0(T0)):	1.86	Kg/m ³
Vapour pressure:	1600000	N/m ²
Vaporization heat at boiling point:	425930	J/Kg
Lower flammability limit:	21000	
Upper flammability limit:	95000	
Concentration of irritation:	100	
Radiated heat fraction:	0.2	
Mass burning rate at infinity:	0.099	Kg/(m ² *sec)

Figure 11: Dialog box for setting the risk-related cost parameters for a new transport.

By filling the New Transport dialog the user defines a new transport, which is a group of not-yet-calculated routes. All members of the transport have exactly the same properties, except for a weighting factor that defines the level of participation of the economic and risk-related cost in the final combined cost which is calculated for each link of the network. As soon as the transport is loaded or defined via the application's graphical interface, the GOOD ROUTE Simulator calculates all the associated economic and risk-related costs for each link and time interval. This most computationally stage of the DSS

operation, however, is only performed once for each transport and its results can be used for any source/destination pair of the subsequent dynamic routing optimization stage.

Once the costs have been calculated, the DSS is ready to calculate the optimal routes. By clicking on the Calculate Routes icon, the user instructs the application to initiate the calculation. The calculated routes are subsequently displayed on the screen. The user has the option to see a property sheet that displays details regarding the calculated route.

Below, the lowest economic cost, the lowest risk-related cost and the lowest combined cost route results are displayed.

The road network is displayed in dark blue, light blue, dark green, light green and orange, depending on the category of each road. The population density is shown in tones of grey. The routes are displayed in tones of magenta, while the nodes that belong to them are shown as black dots, even when we had chosen not to display the other nodes.

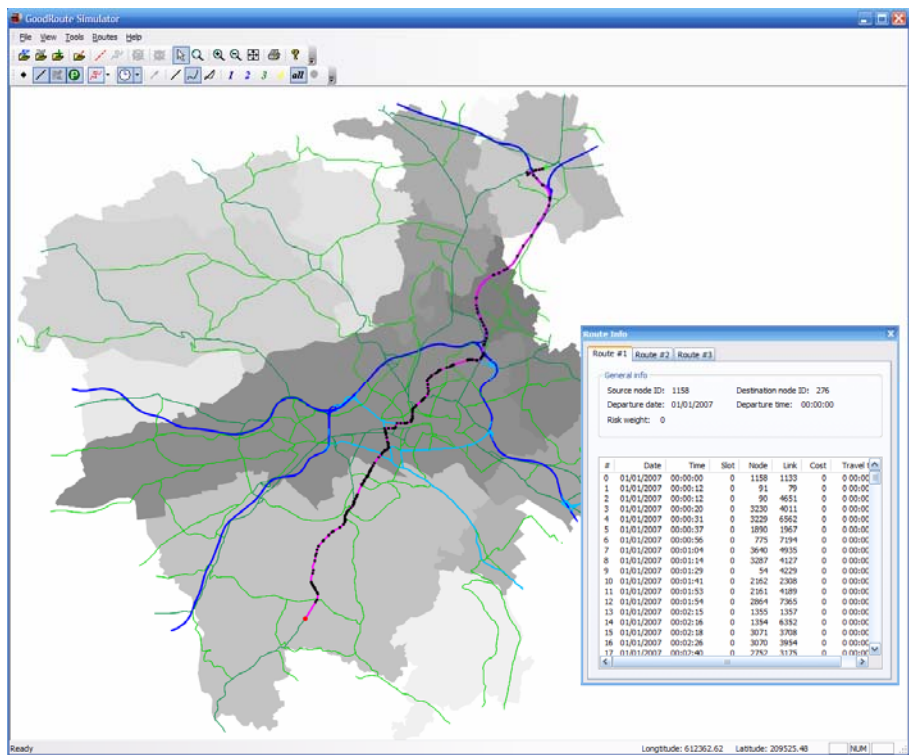

Figure 12: The lowest economic cost route.

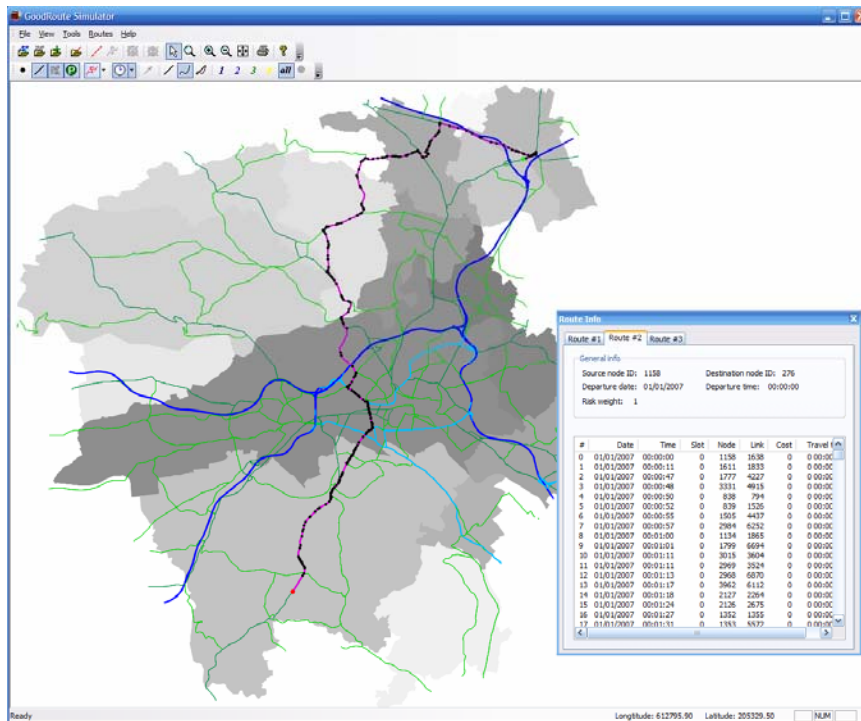

Figure 13: The lowest risk-related cost route.

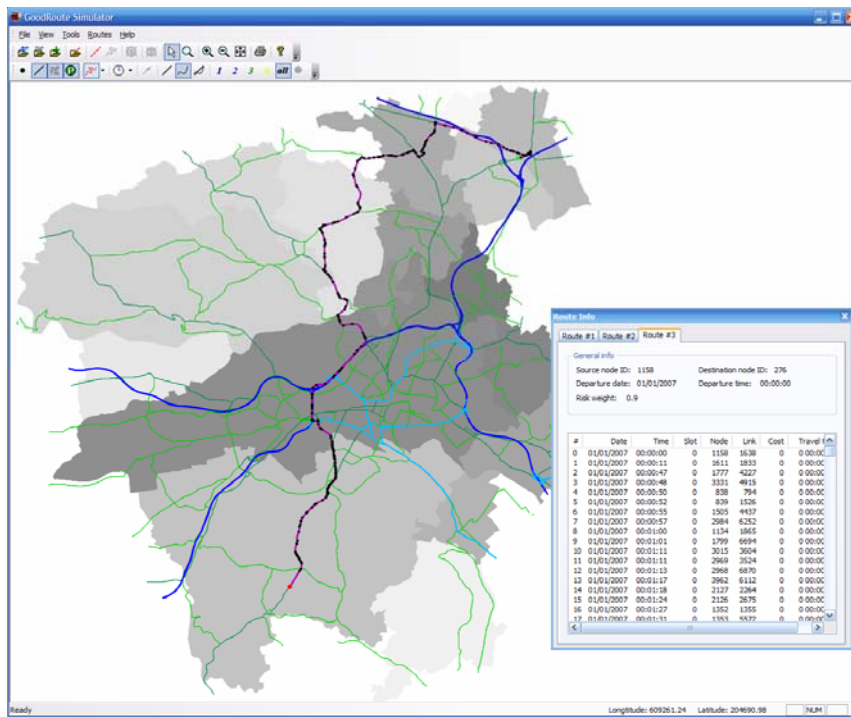
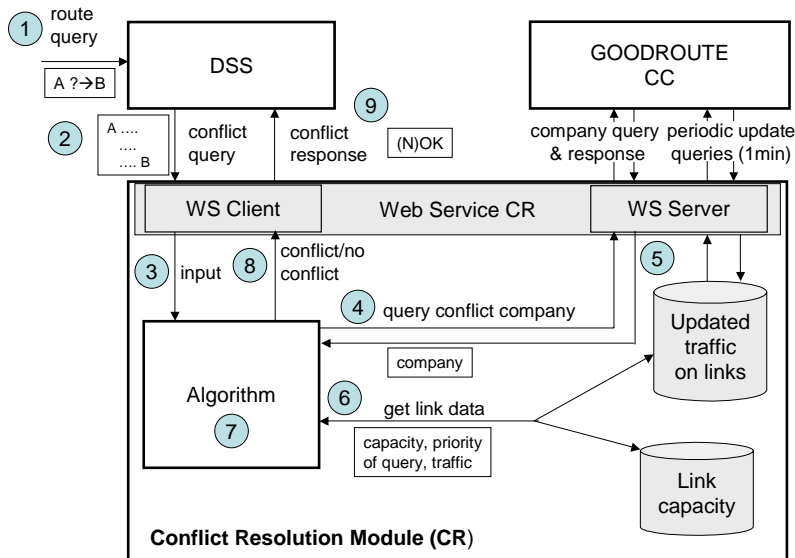
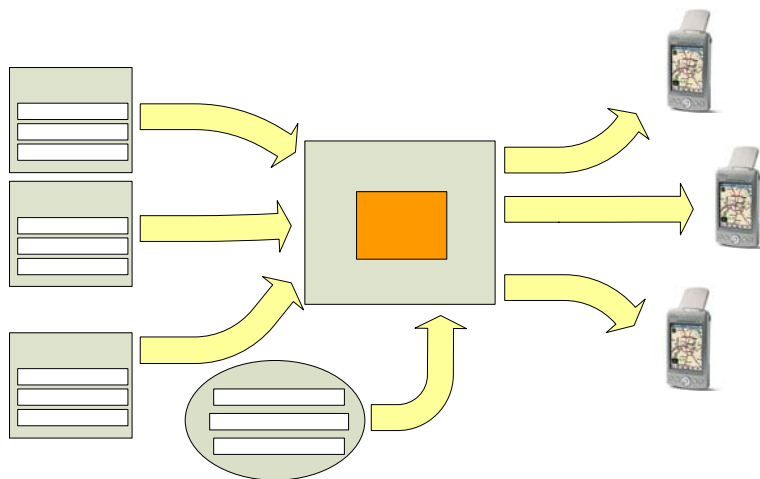

Figure 14: The lowest combined cost route.

The user can also apply temporary restrictions to any link, for any time interval he wants. In that way, they can simulate the procedure of a an alternative route calculation, when the previous one was rejected by the Conflict Resolution Unit.

A decision support methodology has been decided for the developed Conflict Resolution Module for the selection of best route for each transport of dangerous good, based on social demand for risk reduction, and industry demand for minimum costs. The conflict resolution runs together with the DSS on a separate server and it is based on business rules, but also on the alternative rules given by the DSS, which operates upon the Minimum Risk Rules.



CONFLICT RESOLUTION
MODULE

CONFLICT
RESOLUTION
ALGORITHM

Figure 15: Conflict Resolution Module architecture.

The Conflict Resolution Module needs for each route of each truck the risk and cost factors, and also the information that could provide the enterprises (route interests, logistic needs, human factors...), public authorities (about regulatory laws...) and road operators.

A literature review was performed regarding the approaches to Conflict Resolution problems in the areas of Communication Networks, the Railway Sector, Aviation and Resource Allocation. Moreover, the Multi-agent Systems approach was also examined concerning its applicability to the Conflict Resolution problems arising within GOOD ROUTE. This effort led to the identification of three alternative algorithms as possible candidates for implementation. Finally, a Conflict Resolution Module (CRM) simulator was developed to reflect and validated the heuristic approach selected for the conflict resolution in GOOD ROUTE.

Basically the Module receives routes queries from the DSS Module and taking into account some information coming from the CC Module, some internal information (Rerouted routes) and some historical information (Link capacity and transit time through the different links) decide based on the heuristic algorithm selected, which of the routes are allowed to proceed and which have to wait some time. DSS is informed of the delayed routes and of the links that caused these delays.

This module is divided into two Sub-Modules:

- CR Real Time Sub-Module
- CR Tactical Planning Sub-Module

A Conflict Resolution Module simulator has been finally developed, utilising the following info:

- GIS information of the nodes and links of a road network. The simulator can read ESRI shapefiles (SHP) format. From this information link capacity is estimated.
- The information concerning real time incidents is simulated with respective "ext files".

The input of the simulator is a file including a scenario consisting of different routes, each of them is composed of a route identifier, different nodes and the company owner of the DGV.

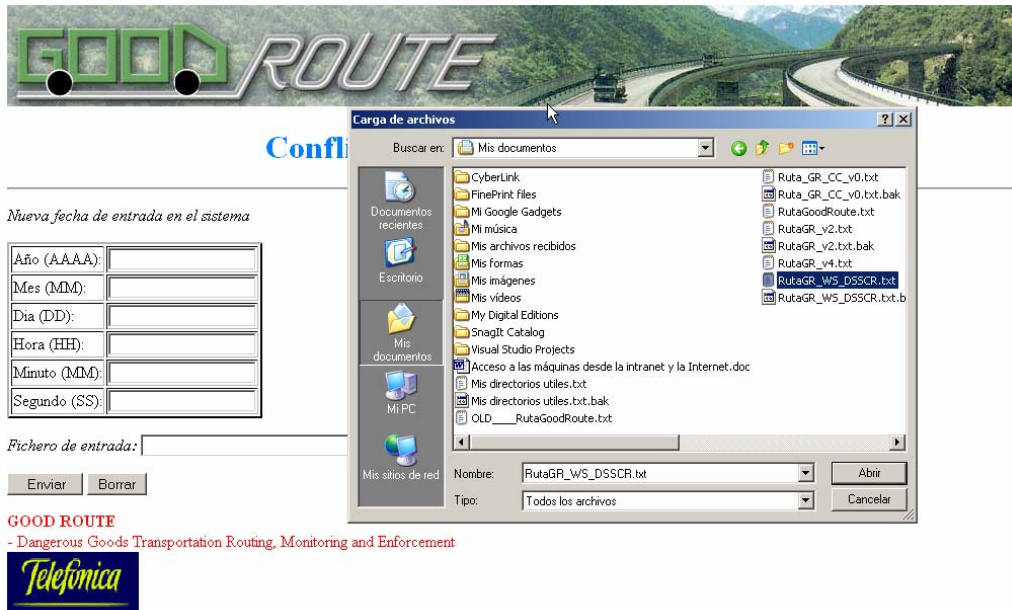

Figure 16: Conflict Resolution Module Simulator.

The output is a simulated response consisting of the different routes identifiers, a Boolean response and a list of the nodes with incidents, so the DSS module could perform the rerouting of the affected DGVs.

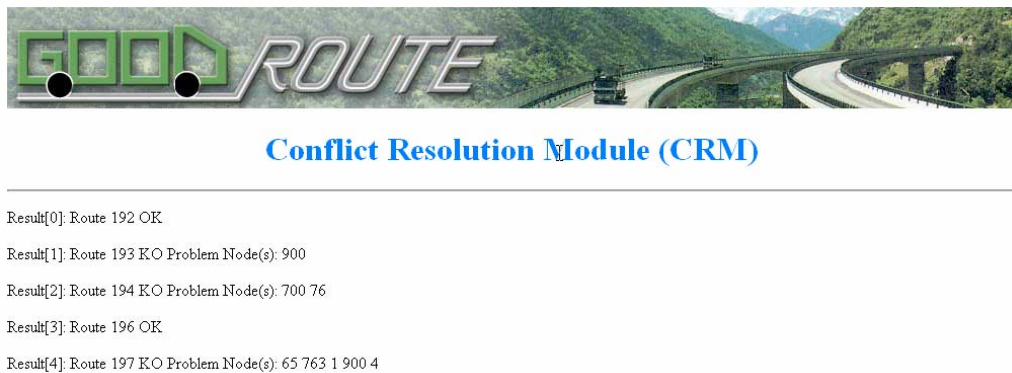

Figure 17: Output of the Conflict Resolution Module Simulator.

The outputs are namely the simulated response consisting of the different routes identifiers, a Boolean response and a list of the nodes with incidents, so that the DSS module will be able to perform the rerouting of the affected DGVs.

To ease the final integration of the CRM a Web Service has been developed to get all the needed information and to receive route requests and answer them.

The navigation client is based on the on-board principle, that is, the route calculation is done on the mobile device. During the second annual review of the project, held on 18-19 March 2008 in Turin, the development of a tablet PC instead of a PDA was proposed by PTV for client navigation. The proposal was well accepted by the EC and it was unanimously agreed that the development plans would proceed upon this basis.

A hybrid system is being implemented which allows to exchange routes between the mobile client and the backend server. The data transfer is done by using GPRS. This approach has also the advantage to be able to run more complex processes regarding the "safest route" on the backend and just transfer the result to the mobile client. It is also easier to integrate dynamic information during route calculation on a backend server system.

The mobile client navigation is communicating directly with a server hosted at PTV and which receives its input from the Data Fusion Platform (Control Centre including the business logic of the system). The route calculation receives input from different sources, such as traffic management centres, weather data bases and the DSS as well.

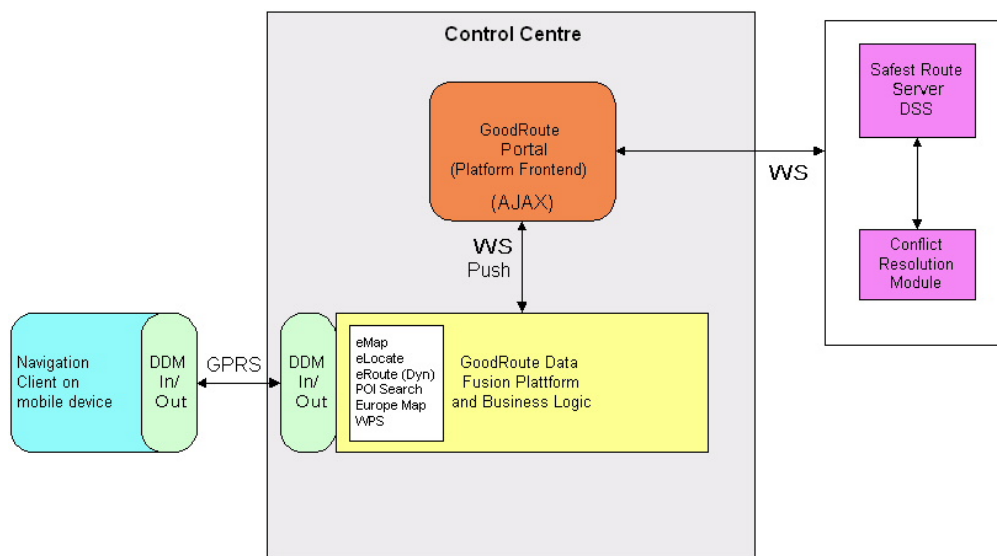

Figure 18: DSS – Control Centre Architecture.

The system will also be able to push event information to the client device (e.g. accident warning).

The navigation application is a standard product available in the market. The necessary adaptations have been made regarding the backend server connectivity and the message

display. It is a software package that runs on mobile tablet PC. The task of the navigation is to give the driver exact driving directions, calculate routes and display maps. Especially the latter function requires a map render engine on the device which consumes a high percentage of the device hardware resources. In order to be able to run the navigation application smoothly on the device, the following list gives an overview over the common requirements regarding the tablet PC hardware:

The navigation system prototype includes a mobile PC, Bluetooth GPS-receiver and a mobile phone, which offers the connection to the internet via GPRS.

The Tablet PC runs Win XP and the screen size of the device is 1000px width and 600px height. The system settings could be adjusted to show the scrollbars width 40 to 50px width to be able to handle it with a finger on the touch screen of the tablet PC; a stylus pen can also be used.



Figure 19: GOOD ROUTE mobile client.

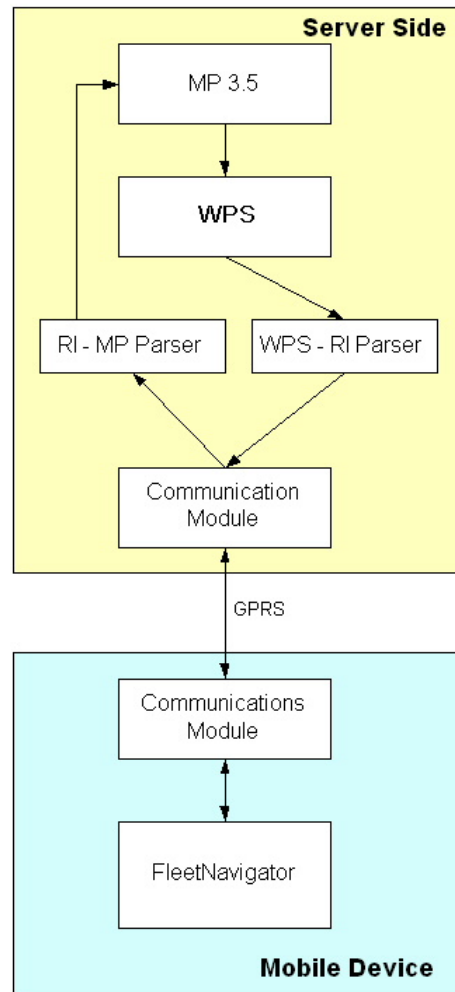

Figure 20: GOOD ROUTE navigation application architecture.

One of the main tasks of this WP was to find a mechanism to convert the routes provided by the DSS as a segment list into navigation readable waypoints. This was done by using a so called WayPoint Server and a conversion module.

In addition to the above work held in the context of WP2, the impact of the Dangerous Goods Vehicles traffic on other road users was shown through the work held in A2.6: “Simulation and optimisation for impact analysis, including other road users”.

The minimum risk methodology gave as a result the DGV paths that minimize the environmental and human risks, without taking into consideration the traffic conditions of the network and the problems that this volume may add. The road users’ impact analysis added the parameter of traffic volume restrains in the above methodology. To succeed that, the network and its conditions were simulated and running the traffic assignment procedure, different minimum time paths were resulted.

These paths were compared with the minimum risk ones and data such as the volumes of the network, while the travel time and the v/c were also analyzed. Further more a

conflict resolution methodology was simulated giving optimized paths for the DGV volumes. In depth analysis of the above results was developed.

The main results from the analysis are the following:

- The routing of DGV based on shortest time & distance paths and traffic conditions gives longer distance paths but utilizing higher capacity and free capacity links of the network.
- The minimum risk routing methodology results to paths that utilize congested links (minor free capacity) of high hierarchy since it seems that the avoidance of dense population areas is dominant criterion for route selection.
- Very negative impact to the traffic conditions in the links involved to the minimum risk route and therefore negative impact to the other users of the road network (this corresponds to Step 2 without the conflict resolution scheme integration).
- Reduction of vehicle kms for the examined area (by 33%).
- Reduction of average speed for auto vehicles (by 14%).
- Increase of V/C ratio for the specific utilized links (by 24%).
- The conflict resolution approach (scenario 3) seems to result to better traffic conditions for the DGV and the other users of the network and decreases negative impacts of scenario 2 presented before.
- A more in depth analysis in the way that the heavy vehicle volumes should be assigned in the network must be implemented according to the methodology followed.
- The final methodology should take into account the safety parameters but also the network conditions, the capacity of the roads, the equable assigned of the volume and the minor extension of the travel time.

The GOOD ROUTE Risk Analysis methodology, algorithms and simulator are described in depth in D2.1: “Risk estimation algorithms”, whereas the DSS operation, the Conflict Resolution Module, the navigation module and the impact analysis are described in D2.2: “Minimum Risk Route Guidance System”. The interface of the navigation module to the Control Centre is described in D6.2: “GOOD ROUTE system integrated at the three sites”.

1.1.4.3. WP3: On board Telematic System (CRF) [Start: M3-End: M22]

Objectives

- To gather the required on-board data regarding key vehicle and cargo parameters, by using, adapting and integrating existing on-board sensors.
- To define and implement an appropriate data fusion algorithm.
- To fuse infrastructure with on-board data, dynamically, in order to provide the route guidance module of WP2 all necessary data.
- To develop a user friendly and intuitive user interface to support the driver.
- To interface existing and emerging V2V systems, to enhance GOOD ROUTE functionality when they are available.
- To design and develop an on board unit, to provide the GOOD ROUTE service.

Activities

A3.1 Autonomous on-board sensors for cargo and vehicle monitoring (CRF)

A3.2 On board data fusion and information synthesis (ICCS)

A3.3 On board HMI (USTUTT)

A3.4 OBU Integration, technical verification and optimization (CRF)

A3.5 Interface to V2V system (CRF)

Work performed and end results

Within WP3, the On Board Telematic System of GOOD ROUTE has been developed.

The overall communication architecture defined in GOOD ROUTE is depicted in the following figures.

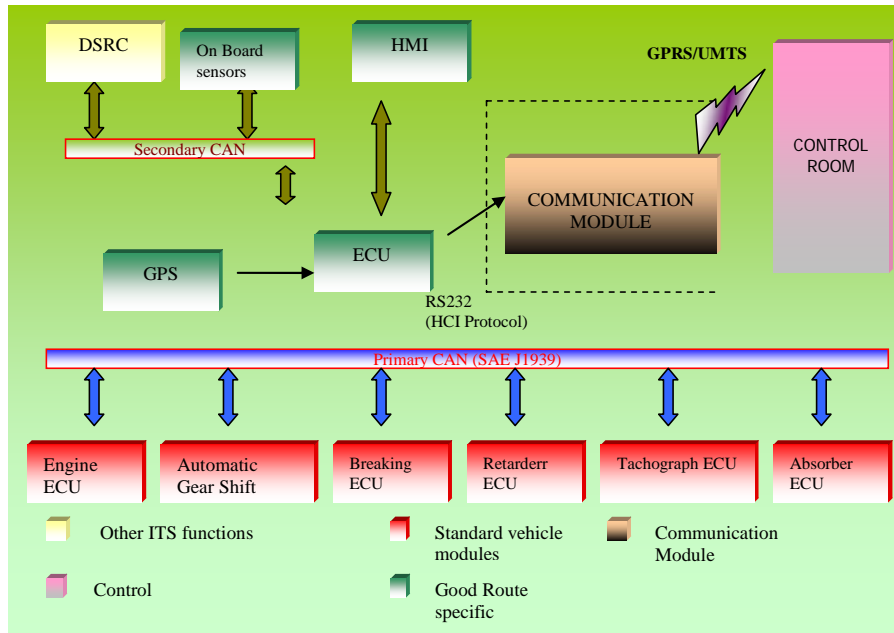

Figure 21: System Overview.

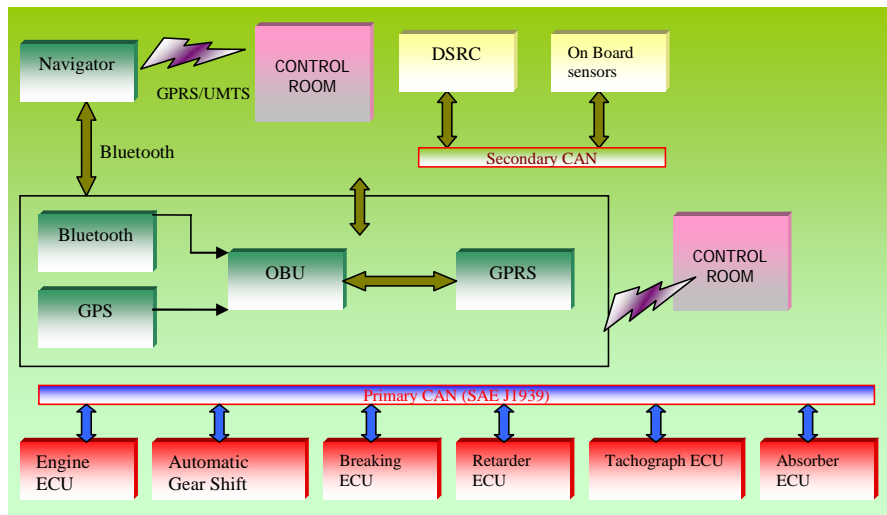

Figure 22: Communication I2V.

Respectively, the telematic system architecture is shown in the following figure.

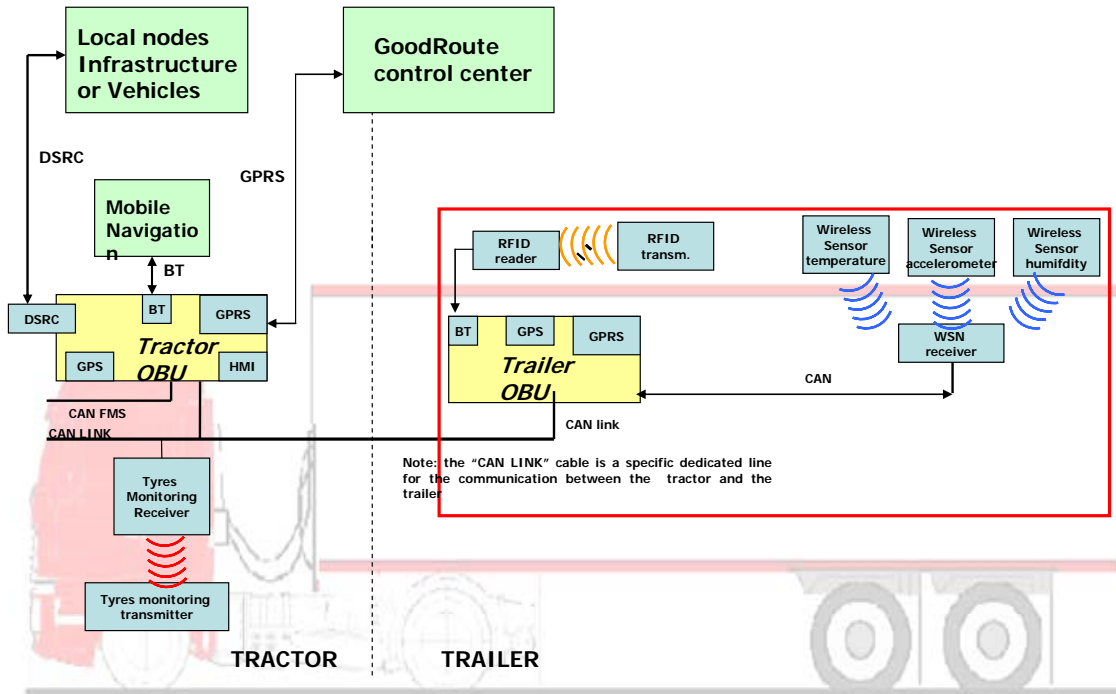

Figure 23: GOOD ROUTE telematic system architecture.

The above figure highlights the high level architecture integrated to provide all functionalities envisaged by GOOD ROUTE. The main entities are:

- The truck , consisting of a tractor and a trailer
- The control centre
- The local nodes

There are two telematic units in the truck. The first is installed in the tractor in order to collect information about the vehicle operations and to manage the short/long range communications and the second one should be installed in the trailer in order to collect information on the transported goods status; dangerous goods are stored in the trailer. In the GOOD ROUTE demonstrator the second telematic unit is installed in the trailer emulator.

It has been decided to develop a "trailer" emulator and to adopt it for the vehicle demonstrator integration in GOOD ROUTE.

The main reasons that pushed this decision are the following:

- To assure the capability to perform tests every where, also in CRF premises, and with any truck driver. In fact in Italy truck drivers that want to drive truck with trailer should own a particular driving licence.

- The specific selection of the type of the trailer (container, tank, etc.) and the type of goods transported (solid, liquid, explosive,...) was out of the GOOD ROUTE vehicle demonstrator scope because the objective of testing activity is to validate the overall GOOD ROUTE system and scenarios. The design of the trailer equipment has been as general as possible, not focused on specific commercial sensors used for monitoring specific goods carried in specific trailers.
- The developed trailer emulator can guarantee all the needed functionalities and represents a good starting point for any future application in the field. The information on emulated cargo, as ADR identification code, dimension and weight are stored in a RFID tag and can be easy changed. The “cargo” status is monitored through WSN and through setting different internal alarm thresholds is possible to emulate different cargo status.

The unit installed in the tractor has the capability to communicate with the unit installed in the trailer and with the control centre. The information exchange between the two on board telematic units is achieved through a dedicated CAN link. The tractor unit is connected to the vehicle control network through the CAN FMS protocol. In order to monitor dangerous goods, the trailer has been equipped with sensors, RFID, specific TAG sensors with low power consumption; all data are collected by the trailer unit and sent to the tractor telematic unit which gathers all the information about the truck.

The data acquired by the on board telematic unit can be sent to the control centre and/or to a local node upon request or spontaneously after a warning condition detection. The local node provides enforcement procedures applied locally and notifies the driver about them. Alternatively, others solutions can be provided by the control centre taking into account global suitable strategies. The control centre is able to exchange information with the vehicle through GSM/GPRS while local nodes will use short range communication link.

The control centre monitors the vehicle and shall verify if the driver has appropriate driving behavior. If necessary, the control centre can apply some enforcement policies that are established in accordance with the local authorities and can decide to send messages to the driver with the suggested guidelines or with the indication to stop the vehicle. A police-car, with the assistance of a device having the capability to communicate with the truck telematic unit, can request the truck to send information about the vehicle functionality and the transported dangerous goods status; after having checked the received data, the police can adopt an opportune strategy to stop the vehicle.

The tractor OBU sends messages to start and stop the trailer OBU cargo monitoring activity.

The trailer OBU sends messages at a constant rate about the cargo status information. If the tractor OBU doesn't receive any message from the trailer OBU within a certain time interval, it sends to the GOOD ROUTE Control Centre a warning message in order to communicate technical problems on cargo status monitoring system.

Both the tractor and the trailer OBU are integrated into the same type of device, the Blue&Me™ device developed by Fiat Auto, Magneti Marelli and Microsoft Automotive Business Unit, an innovative solution based on Windows Mobile for Automotive, which performs in-car communication, information, and entertainment functionalities.

Blue&Me is available on new and restyled models from the Fiat Group (FIAT Automobiles , IVECO, CNH).

The Tractor is equipped with the IVECO Telematic platform (“Blue&me Fleet”) and provided with a front panel display for HMI, WABCO tire pressure monitoring system and DSRC module for short range communication. The on board unit is also connected to a radio system and integrated with a microphone. The tractor telematic platform is connected to the CARGO equipment so to receive cargo data and warning of irregular condition on goods status.

The main subsystems of the GOOD ROUTE tractor architecture are the following:

- OBU (On Board telematic Unit) for wireless communication; it is connected to the vehicle CAN bus network and to the trailer OBU through a dedicated CAN link;
- The HMI system;
- The Dedicated Short Range Communication (DSRC) system for enforcement application;
- The tyre pressure monitoring system (WABCO);

From the communication links architecture point of view, the tractor on board unit uses:

- BlueTooth short range communication link toward an on board navigation system.
- DSRC short range communication link toward the infrastructure and local nodes.
- GPRS long range communication link towards the GOOD ROUTE Control Centre.

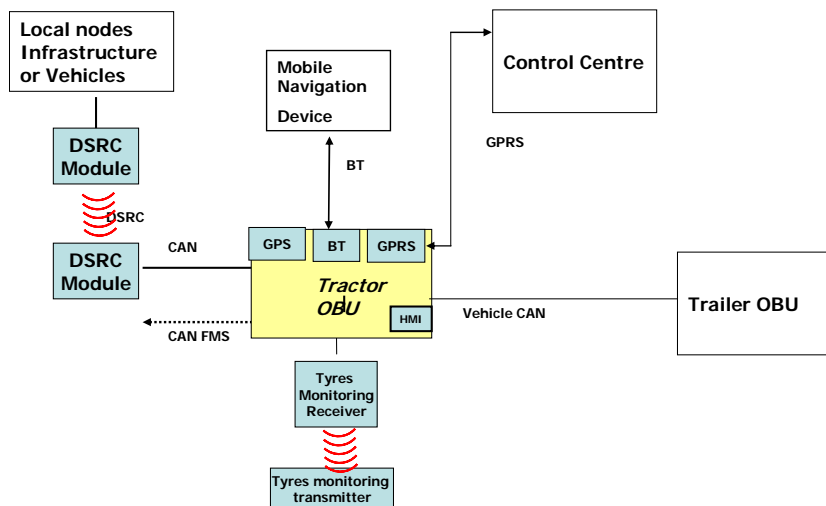

Figure 24: Tractor architecture.

The main functionalities of the tractor OBU are summarised below:

- To monitor vehicle operating parameters.
- To monitor driver behaviour.
- To provide position information to the navigation subsystem.
- To receive the status of the goods in the cargo, to handle the status and provide warning to the driver in case of specific events.
- To interface TPMS sensor and provide information on the wheel status.
- To manage HMI with the driver.

A specific tool has been developed on the IVECO OBU with the purpose of acquiring vehicle data; these data are then analysed in order to determine the status of the vehicle and the driving behaviour of the driver. The two status parameters provide information to the GOOD ROUTE Control Centre about the vehicle capability of continuing the travel and the driver respect to the driving rules respectively.

The information is provided also to the driver through a specific HMI (shown below); messages can be displayed on the OBU front panel or converted to voice and heard through the radio system.

The same HMI is used for the enforcement messages received from the local node.

The tractor OBU sends general information to the trailer OBU (i.e. start, stop,) while the trailer OBU sends information about the cargo and cargo status. The unit installed in the tractor has also the capability to communicate with the Control Centre. The tractor unit is connected to the vehicle control network through the CAN FMS protocol.

The tractor OBU collects information about the vehicle operations and manage the short/long range communications and the trailer one collects information on the transported goods status; dangerous goods are stored in the trailer.

The data acquired by the tractor OBU are sent to the control centre and/or to a local node upon request or automatically after warning condition detection. The local node provides enforcement procedures applied locally and notify the driver about them. The Control Centre is able to exchange information with the vehicle through GSM/GPRS while local nodes will use DSRC short range communication link.

The OBU is perfectly integrated inside the tractor cabin. It is placed in front of the driver near the stereo, the navigation system and the chrono-tachograph and can be easily managed by the driver himself.

The OBU functionalities don't require any interaction with the driver; there are almost automatically and the on board HMI is simple and oriented only at the visualisation of elementary messages.

The HMI functionalities are based on front panel display visualization or on vocal messages obtained through a text to speech tool, already integrated in the OBU. The voice messages are managed through radio connection and microphone integration.

The OBU Platform uses the on-board Radio Equipment to play announcements to the driver; these announcements can be relevant vocal messages on vehicle and cargo status and on re-routing requests from the Control Centre. In order to do this, the system is

connected to the Radio by means of an analogical channel in order transport the audio signal and an On/Off signal to control the radio.

The OBU is connected to a front panel display equipped with a dot matrix display; the visible area is 67 mm x 35 mm (W x H), where short text messages can be displayed. On the front panel some pre-configured push buttons are available to the driver.

The parameters that are shown on the front panel display are cargo status, cargo data, WSN configuration, tyres status. All these parameters can be shown on the display simply selecting the respective entry in a pull-down menu. The driver can gain access to the GOOD ROUTE Menu pressing the button with the receiver symbol and move inside the directory scrolling the UP/DOWN items. This allows to go respectively to Previous page (arrow DOWN) and to Next page (arrow UP).

About the cargo status, the driver can have information about light, temperature, pressure and humidity of the trailer environment in real time, simply selecting the respective entry in the pull-down menu.

The parameters for the cargo data that can be displayed are ADR codes, cargo weight length, width, height. The driver can have this information simply selecting the respective entry in the pull-down menu.

The driver can have information about different tyres pressure, simply selecting the respective entry in the pull-down menu, as follows:

- Within the WSN directory there is also a configuration section that allows the driver to set and change the reference threshold values of the sensed parameters for all the wireless sensor nodes. In the WSN area the driver can select different options, one for each node and a configuration reset command.
- During the trip, in case of need, the driver can send an emergency message simply pushing an E-call button on the OBU front panel. Moreover, to report and signal a generic event from the GOOD ROUTE Navigation system the driver can push a dedicated button symbolizing a stylized truck.

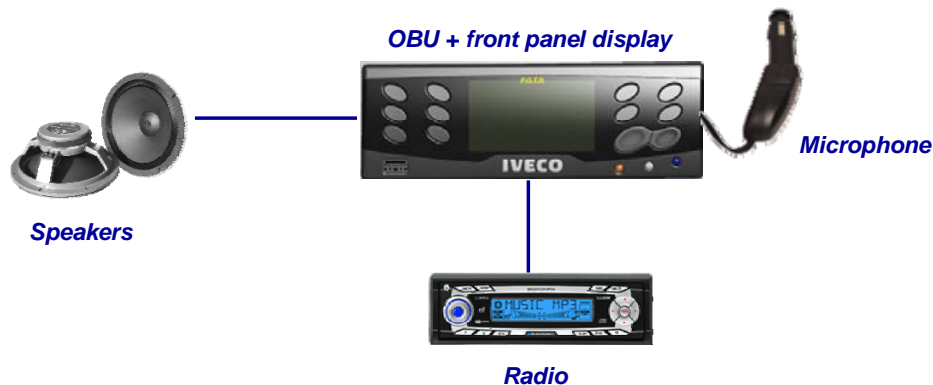

Figure 25: In-Vehicle HMI architecture.

The OBU is connected to the front panel display by means of B-CAN interface.

The main functionalities of the trailer OBU are summarised below:

- To monitor the presence of the cargo, and the ID so to understand if some part is lost or stolen during the trip or during the storage; this will be achieved through the reading of one or more RFID tags (one in GOOD ROUTE project).
- To monitor the status of goods in tanks by a specific set of sensors installed on (or inside) the tanks; this will be achieved through the use of wireless sensors network

All the information is gathered in the relevant OBU and after a processing, are sent to the tractor OBU.

The main subsystems of the trailer emulator are:

- OBU (same model as tractor OBU)
- Wireless Sensors network for cargo monitoring
- RFID reader + RFID tag for cargo identification

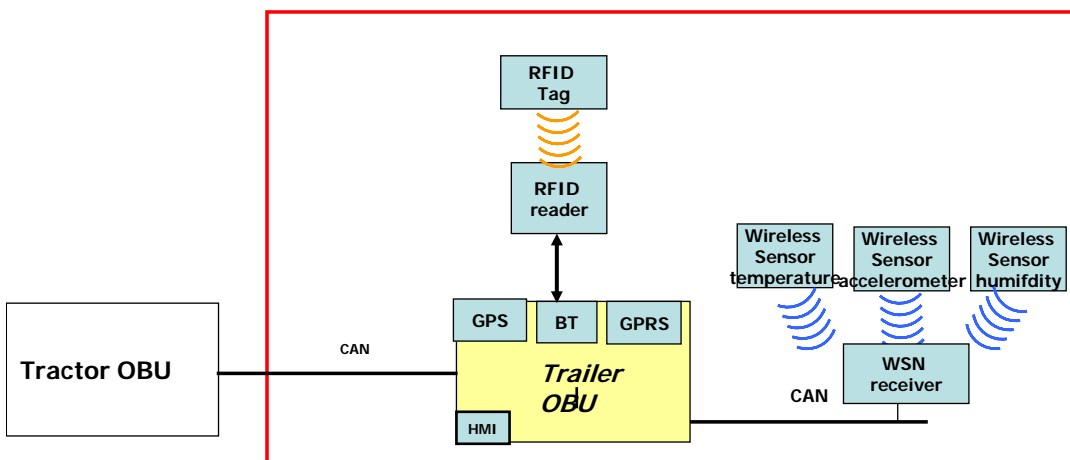

Figure 26: Trailer architecture.

In the following picture the developed trailer emulator box is represented:



Figure 27: Trailed emulator box.

The cargo monitoring tool aims to verify the status of the cargo; the architecture is formed by the trailer OBU connected to the tractor OBU through CAN link, to a WSN system for acquiring important parameters about cargo and to a RFID device.

All the data are acquired at about the same rate; then are analysed by the OBU in order to determine a cargo status variable that is sent to the tractor OBU.

The information on emulated transported goods, as ADR identification code, dimension and weight are stored in a RFID tag. The RFID reader selected for GOOD ROUTE project is the Baracoda, IDBlue Bluetooth enabled RFID 13,56 reader/writer. It is interfaced to the trailer OBU telematic platform through Bluetooth link.



Figure 28: Baracoda RFID reader.

The “cargo” status is monitored through WSN and through setting different internal alarm thresholds is possible to emulate different cargo status.

The wireless sensor nodes that have been selected for GOOD ROUTE vehicle are light, temperature, barometric pressure and humidity.

Every node periodically acquires one or more parameters from the sensor unit and forward those to the transceiver that is connected to the trailer OBU through a dedicated CAN line.

A node can be programmed to provide sensor readings with a scheduled timetable or when a trigger value has been passed. The transceiver node is powered from the vehicle battery. With the “key on” signal it performs the following functions:

- It overlooks sensor nodes functioning. It commands nodes to start/stop acquisition and to send messages with sensor readings.
- It receives sensor readings and forward them to the OBU system by means of the WSN-CAN interface.
- Based on a user input it can command sensors nodes to change their settings, in order to modify the transmission frequency; change the node status (Power on, power off, sleep), manage wake up timetable.

Each Sensor node is powered by batteries, so when turned on it will be constantly alive. It performs the following functions:

- It periodically acquires sensor readings;
- It forwards sensor readings to the transceiver node.

From the received information, the GOOD ROUTE application is able to have an updated view of the type and amount of transported cargo.

Another aspect that should be considered for the future is the integration with a vehicle to vehicle communication system, as for example the one that is to be developed within the CVIS EU IP project. Because the CVIS router box for wireless communication was still on testing when the GOOD ROUTE architecture was defined, it could not yet be integrated in the GOOD ROUTE vehicle architecture. The DSRC solution that has been adopted in the GOOD ROUTE project to perform vehicle to local node communication needs some development and specially more tests in order to be used for V2V applications. However, the possibility to use the GOOD ROUTE DSRC system in order to communicate to a navigation client located in a different vehicle could be investigated. A tool with V2V communication for enforcement seems to be a promising area for highway patrols applications. The overview of the V2V standards and initiatives and the communication potential in GOOD ROUTE is also reported in D3.2: “OBU”.

Validation tests have been performed to validate the GOOD ROUTE system integrated into the IVECO truck (in the context of A3.4: “OBU Integration, technical verification and optimisation”).

The tests validation activity has been divided into three main types of tests.

- **Electrical validation** of the harnesses and system components;
- **Functional validation;**

- **Field validation.**

The first validation activity was oriented to validate the harnesses that has been designed and installed in the vehicle and then the system components electrical integration into the vehicle. Therefore all the electrical contacts have been verified with a tester while the engine of the vehicle was off.

The CAN messages availability have been verified with the engine on and the vehicle stopped. In a second phase, different trials have been carried out with the vehicle in motion in paved roads and different driving conditions to check the solidity of the wiring and of the internal integration.

The Functional validation consisted primarily into validate separately the main functionalities of the GOOD ROUTE vehicle systems:

- Tractor OBU integration in the vehicle;
- Communication tool between tractor OBU and DSRC system;
- Trailer OBU integration with RFID reader and WSN devices for trailer; emulator cargo monitoring;
- Vehicle monitoring tool;
- Cargo monitoring tool;
- The communication tool between tractor and trailer emulator;
- The communication tool between tractor OBU and GOOD ROUTE Control Centre;
- HMI system (generation of the correct HMI output to forward the correct GOOD ROUTE messages to the driver);
- Verification of the comprehension and the visibility of the messages in the in-vehicle HMI.

In order to validate the single subsystems a series of tests (reported analytically in D3.2: “OBU”) has been performed. In many cases the execution of the test has been based on the interaction with other subsystem. Therefore, the result of a particular test can represent a validation for other part of the system. Both the GOOD ROUTE CAN bus and the vehicle CAN network have been constantly monitored by means of dedicated tools to verify the appropriate flow of messages between all the modules. This validation has been performed with the engine on and the vehicle stopped, as follows:

After having validated the single system components, the overall functionalities have been tested in a testing circuit while the vehicle was moving (field validation).The worst cases for GPRS communication capabilities have been tested in terms of connectivity: it has been verified the overall functionality in case of lost of connection and the capability of the system to resume the connection. The short range communication (DSRC) was tested with the first version of local node.

In all the technical verification tests (performed prior to the Pilots), the vehicle GOOD ROUTE functionalities were positively performed, although the DSRC device, used for the enforcement use case, seemed to be rather sensible to antennas positions.

Besides the in-vehicle HMI, an interface was also developed for the navigation module (presented in previous WP2), in the context of A3.3: “On board HMI”.

As aforementioned, the GOOD ROUTE Client is being operated as an application on a standard Tablet PC. Fully fledged for the GOOD ROUTE system the Tablet PC is connected to the internet via a GPRS or an UMTS connection and receives GPS position information via a GPS device.

The driver utilizes the touch screen to operate the Tablet PC, including the GOOD ROUTE Client application.

The Tablet PC offers the driver GOOD ROUTE guidance by the Client application. Therefore, the calculated route is being displayed to him on the map. The driver can zoom in and out of the map, so he can get an overview if needed. Moreover a maneuver list provides him with further details, e.g. distance and arrival time.

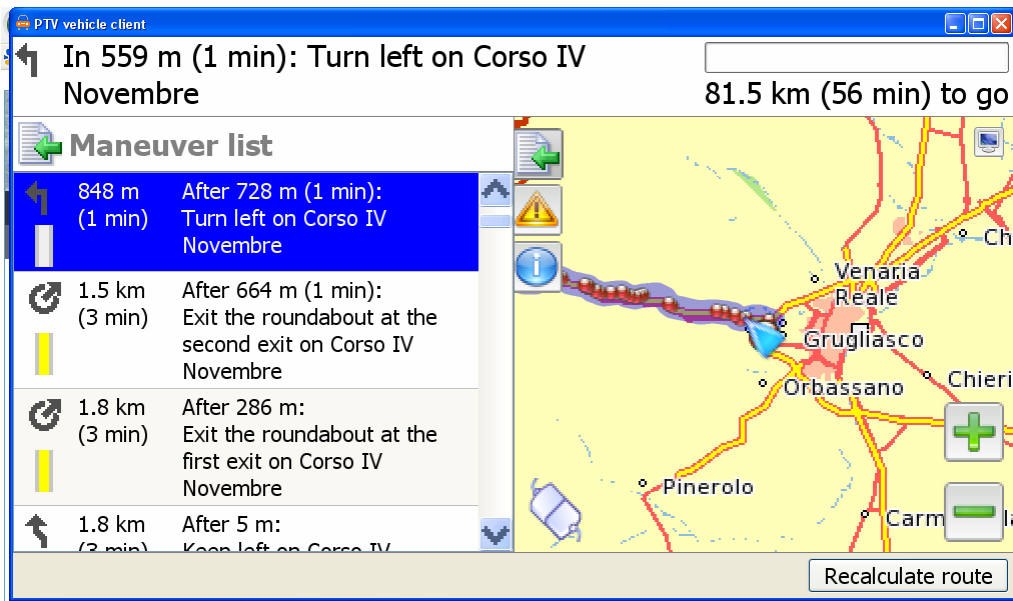

Figure 29: GOOD ROUTE Client – maneuver list.

Further feature of the GOOD ROUTE Client application are the list of points of interest and the list of traffic information. Both, points of interest and traffic information are also displayed to the drivers by characteristic icon on the map.

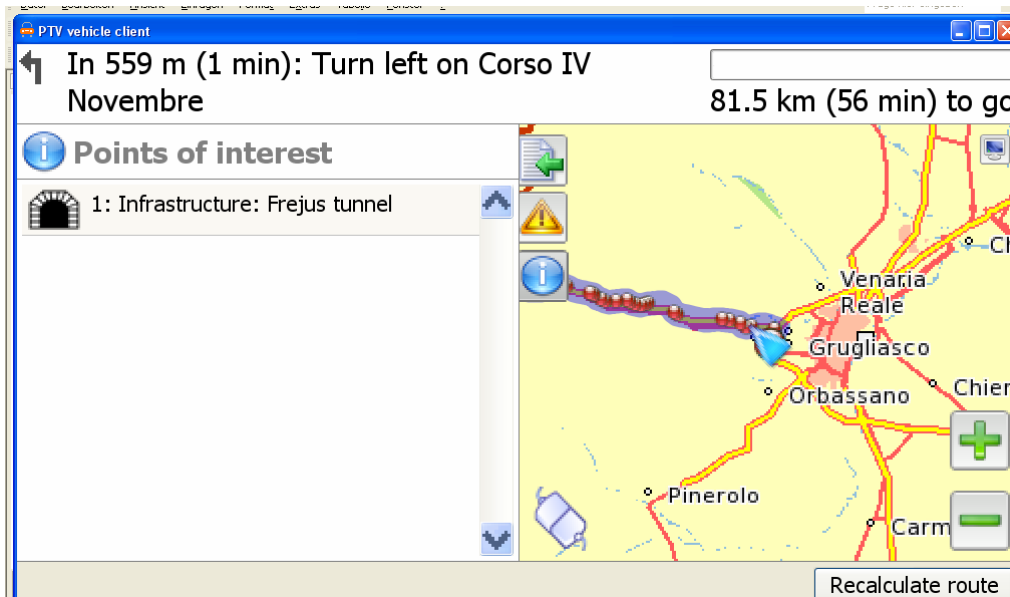

Figure 30: GOOD ROUTE Client – Points of interest.

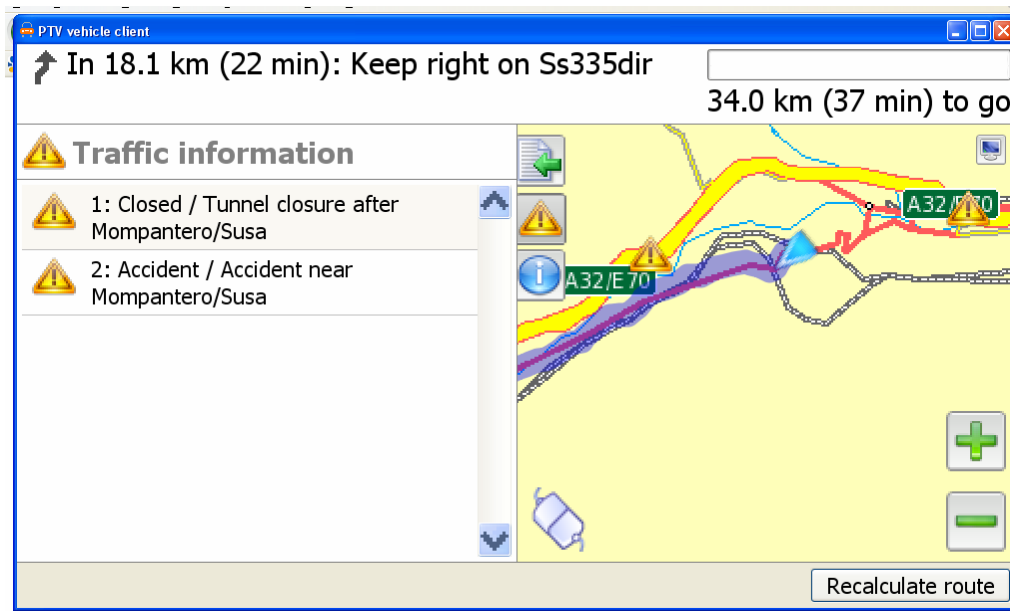

Figure 31: GOOD ROUTE Client – traffic information.

The GOOD ROUTE client is linked permanently to the GOOD ROUTE Server, thus in case of a change in the traffic situation, e.g. an incident on the calculated route, the driver receives an update information. Having received a changed route, the driver has to check the ok box to prove he has received the updated route and to continue the guidance.

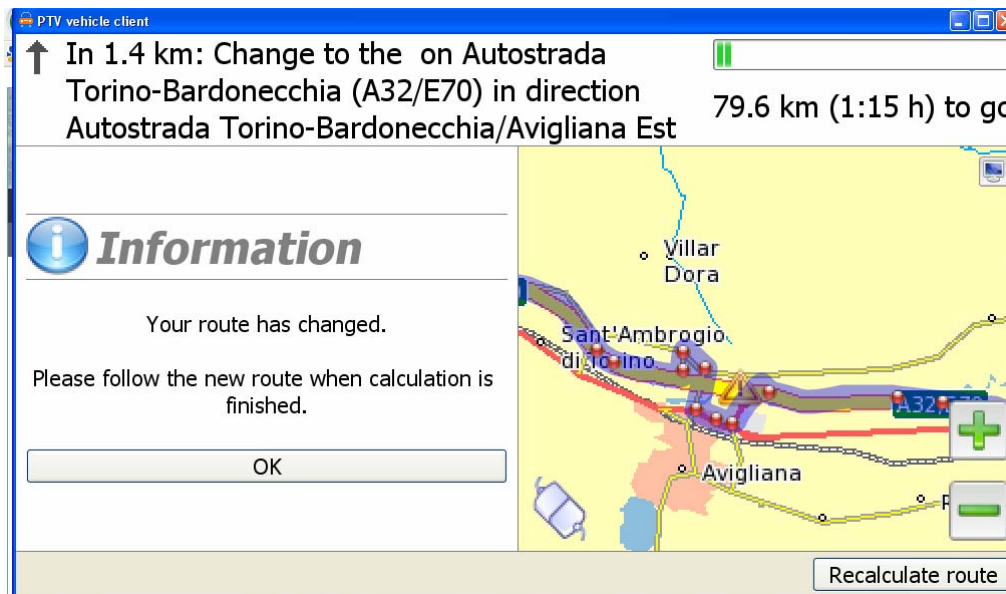

Figure 32: GOOD ROUTE Client – information of changed route.

After the first draft of the driver's HMI, further feedback was collected from the project Consortium and changes in the interface were done accordingly. The resulting HMI was then tested with representative users (4 male truck drivers in Greece) in order to identify final optimisation potentials and in order to receive a global feedback on the actual implementability of the interface. After the test, the design was again optimised for the last time, resulting in the interface depicted above.

No significant usability problems were encountered in these tests. The reason for this is probably to be found in the simplicity of the interface. All functions tested require a very small number of interactions. Neither are the different interfaces complex, nor is their number too big to get a good orientation.

The only complex function of the drivers interface is the route planning function. It was not possible to test this wizard thoroughly because this would have required more than a website prototype. In order to do this, it would have been necessary to have a self-adjusting interface, which could only be achieved by programming all necessary backend processes.

Nevertheless, changes in the driver's interface had to be made due to the changes indicated by the results of the user testing with dispatchers (see WP4). It was planned to have the route-planning functions of dispatchers and drivers produce exactly the same informational output to the system, hence facilitating the technical deployment. Therefore, the drivers' route planning function had to be adapted. As the function grew even more complex, it was decided to facilitate the driver's orientation by giving up the wizard-dialogue and implementing a recurrence-dialogue.

The OBU and the overall telematic system, the driver interface (both in-vehicle and tablet-PC based), as well as the technical verification tests and usability tests are fully reported in D3.2: "OBU".

In addition to the above, in the context of A3.2 “On board data fusion and information synthesis”, OBU data fusion algorithms and a simulator have been developed.

The defined algorithms have been implemented after series of iterations, complemented by laboratory testing and validation. For that reason, a simulator was developed to test their functionality and performance.

The role of the data fusion module inside the OBU is to serve as an interface between sensor data input and GOOD ROUTE control centre, roadside infrastructure and GOOD ROUTE portal. The internal Data Fusion module architecture is illustrated in Figure 33; it is separated into three individual sub-modules (embedding the corresponding algorithms developed) that deal with:

- (1) **Enhanced Vehicle Localization** using the output of the two GPS sensors (one from the navigation unit and one additional from the OBU) and fusing their info with the vehicle dynamics data, available in the CAN bus;
- (2) **Preventive Diagnosis and Risk Classification** after systematic processing of the collected data in order to classify the risk of the following failures: engine start up, stop and go profile, waiting at traffic light 1 (acceleration), waiting at traffic light 2 (clutch) and speed profile in highway;
- (3) **Statistical Analysis** of the data coming from the vehicle’s sensors, including engine and fuel temperature, engine speed, status of the clutch and break switch etc.

All in all, the result of the relevant workpackage (WP3) is an OBU that is able to fuse all available information coming from the sensors, supports the DSS of WP2 and provides support to the dangerous goods driver. The GOOD ROUTE data fusion module is assigned with the sensors’ data fusion task, so as to support the relevant GOOD ROUTE use cases.

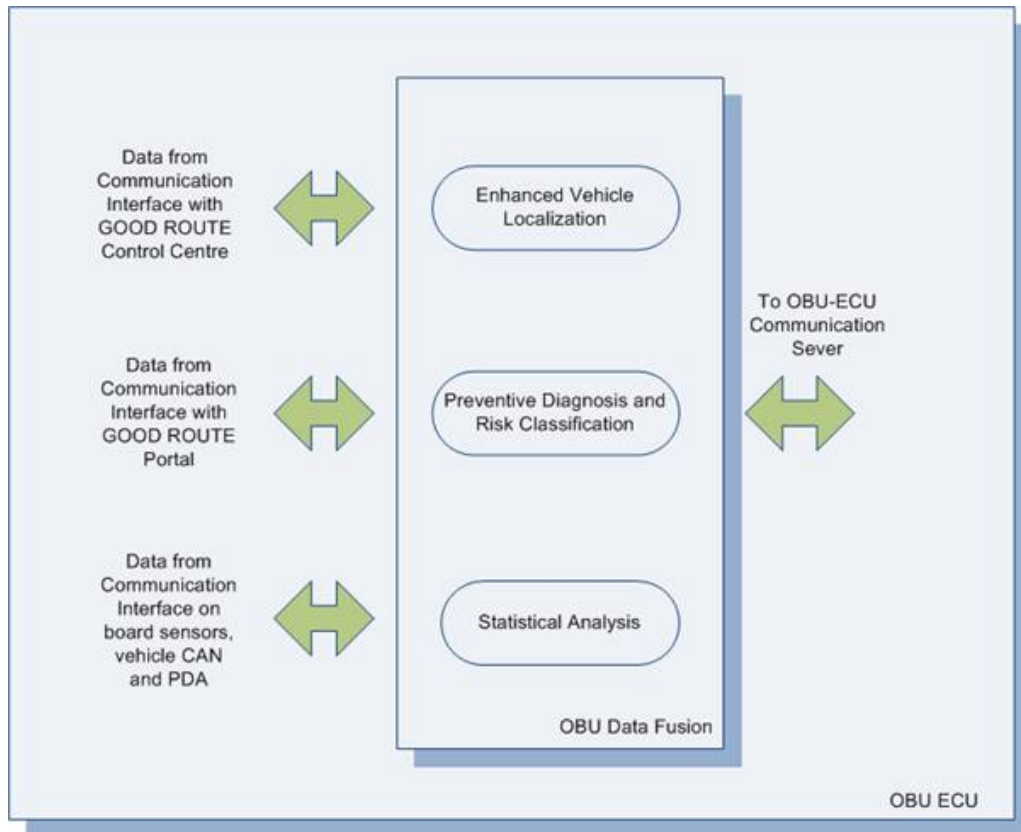

Figure 33: OBU DF internal modules.

The GOOD ROUTE OBU data fusion simulator is a Matlab application that was built for simulating and testing purposes of the GOOD ROUTE OBU data fusion module. It has a clear, detailed and highly configurable user interface, and it has been used mainly for testing purposes, within the development process of the OBU data fusion module. The GOOD ROUTE OBU data fusion module simulator applies the *Enhanced vehicle localisation* (ELV), the *Preventive diagnosis and risk classification* and the *Statistical analysis* as an output. That outputs can be displayed on the screen.

The main menu of the GOOD ROUTE data Fusion Simulator is depicted in the following figure. It encompasses an HMI which visualises the functionality of the Enhanced Vehicle Localisation module, while it also includes a link to both the Preventive Diagnosis and Risk Classification, and the Statistical Analysis Simulators. The HMI of the simulator has been enhanced, upon the 2nd annual review comments.

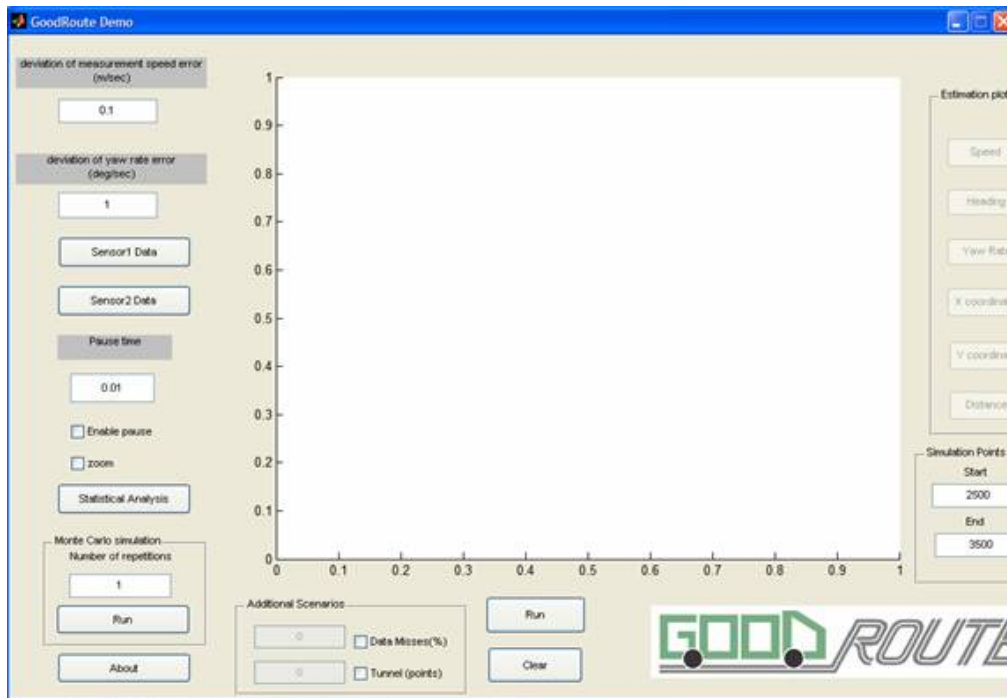

Figure 34: GOOD ROUTE OBU Data Fusion Simulator main menu.

The algorithms developed as well as the detailed functionality and the way to use the simulator, are described in GOOD ROUTE D3.2 “On board data fusion algorithm”. The OBU data fusion simulator is uploaded on the GOOD ROUTE website as well, available for public download and use.

1.1.4.4. WP4: Infrastructure Telematic System (TID) [Start: M3-End: M22]

Objectives

- To provide to the dangerous goods vehicle dynamic traffic, road and weather data, to calculate routing and re-routing, as well as any business related info from the logistics chain.
- To communicate vehicles position, cargo and route info to the Control Center for monitoring to its logistics chain for planning.
- To develop the necessary algorithms and user interface at the Control Center, in order to monitor effectively all dangerous goods vehicles in its boundaries and correspond optimally to emergencies.
- To develop the necessary algorithms and user interfaces at the dangerous goods logistics chain level, to allow effective monitoring of the vehicles position, route and expected delivery time at any moment, as well as to allow it to provide guidance and feedback to its vehicles.
- To integrate available modules related to a telematic system, providing a synchronised operation between them in normal situations and being able to perform asynchronous processes, when necessary.
- To communicate (an adapted exchanged information) with external entities on GOOD ROUTE environment, such as DSS, companies, mobile communication units (trucks).
- To integrate all the above elements at a Central Processing Unit at the Control Center, allowing interconnection of all key actors for operators optimisation, accidents/incidents avoidance and emergencies handling.

Activities

- A4.1 Vehicle to Control Center Communications (CRF/SIEMENS)
- A4.2 Semantic Service network (CERTH/HIT)
- A4.3 Control Center Data Fusion and integration (PTV)
- A4.4 Control Center and logistics chain User Interface (USTUTT)
- A4.5 Logistic chain support system (CERTH/HIT)

Work performed and end results

The Vehicle to Control Centre communication was defined in the context of A4.1 and is incorporated in the WP3 and WP6 overall communication architectures; thus its description is not repeated here.

The Semantic Service Network was defined in the activity 4.2 and incorporates the algorithms developed at the control centre to fuse the information from the activity 4.3, also covering partially the activity 2.5 where the risk estimation and decision support system are developed.

Upon the A1.5 ontology (included in D1.1), the formulation of the semantic service framework has been established to be implemented finally in A4.5.

These semantics were based upon a survey conducted by the respective CERTH/HIT team in order to identify all the possible functionalities and requirement from the users *vis-à-vis* the Logistics support system to be integrated in the GOOD ROUTE system. Part of the semantics were reported also in D1.1. The specifications of the Logistics Support system and its profile as well as the relevant benchmark for the development of the logistics support system which gave the guidelines for its implementation in conjunction with the needs of the core modules and components of the GOOD ROUTE system is reported in D4.1: “Semantic Service Network and Control Centre data fusion algorithms”.

The main outcome of the overall work held is the compliance of the entire logistics support system with the GOOD ROUTE Use cases. Based on the above, the main information flow - “the Semantics Service Network”- was designed for the logistical component of the GOOD ROUTE system and may be depicted in the following figure:

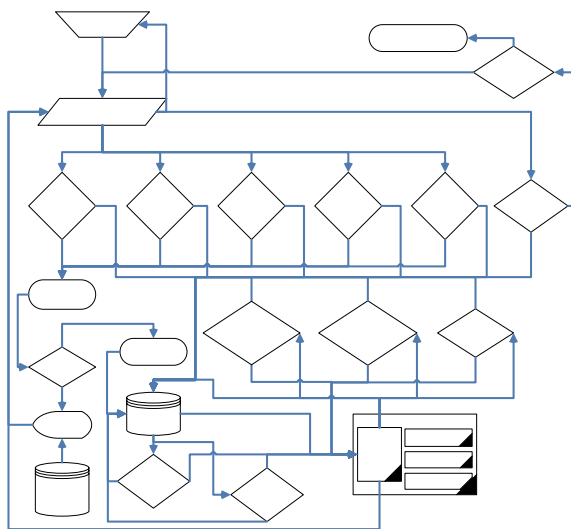
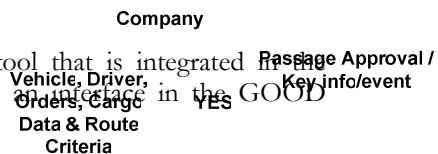

Figure 35: Overall Semantic Data framework of LSS.

The Semantic Service Network is built based upon the results from the surveys and structure of the supply chain of dangerous goods, the information flow and transactions between the actors of the dangerous goods supply chain (info related to the goods, driver and vehicle status, position, route, estimated time of arrival, estimated transportation cost and any actual or foreseen events during transportation), being compatible to the most widely used logistic systems in the area. It allows actors in the chain to add info on the network that will have as recipients other actors or the vehicles’ drivers, through the Control Center.

The logistics support system of GOOD ROUTE is a tool that is integrated in the Control Centre of the GOOD ROUTE system and has the following interface:



ROUTE portal. The basic role of the module in real life would be the information capture from the industry through the portal. This communication interface would also provide back to the user of the GOOD ROUTE system alerts that would be available from the DFP concerning the status of the delivery, incidents, etc.

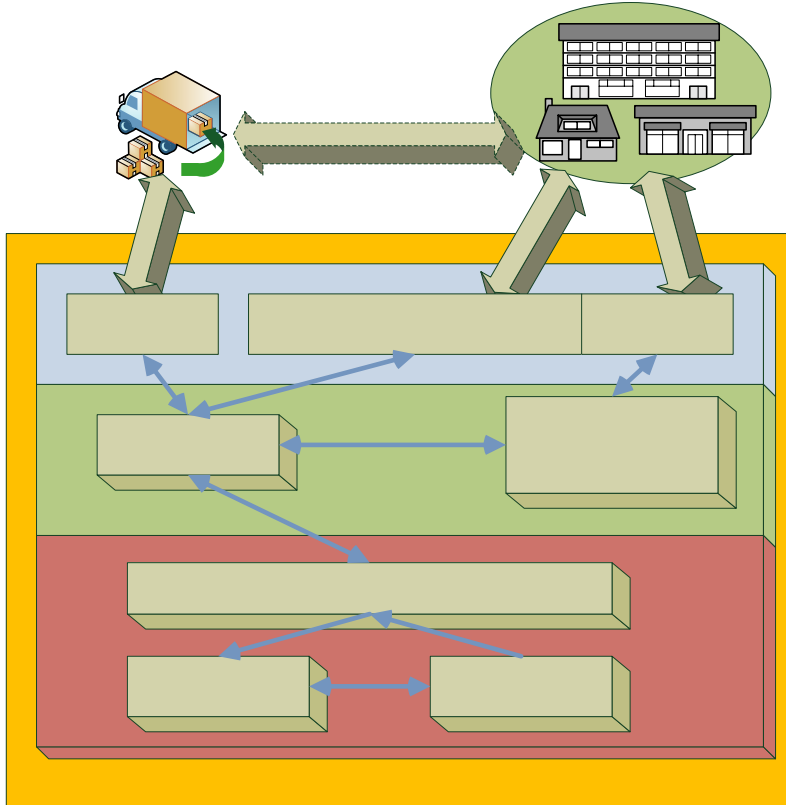

Figure 36: Logistics Support System within GOOD ROUTE.

The levels of communication between the LSS and the company may be achieved according to the possibilities of the GOOD ROUTE according with the following:

Tactical level planning

- **Collect information from the industry**
 - Cargo characteristics:
 - Vehicle characteristics:
 - Itinerary characteristics
- **Provide the requested data to the Control Center**
- **Store collected information and scenarios for future use either temporarily or permanently**

After route execution communication

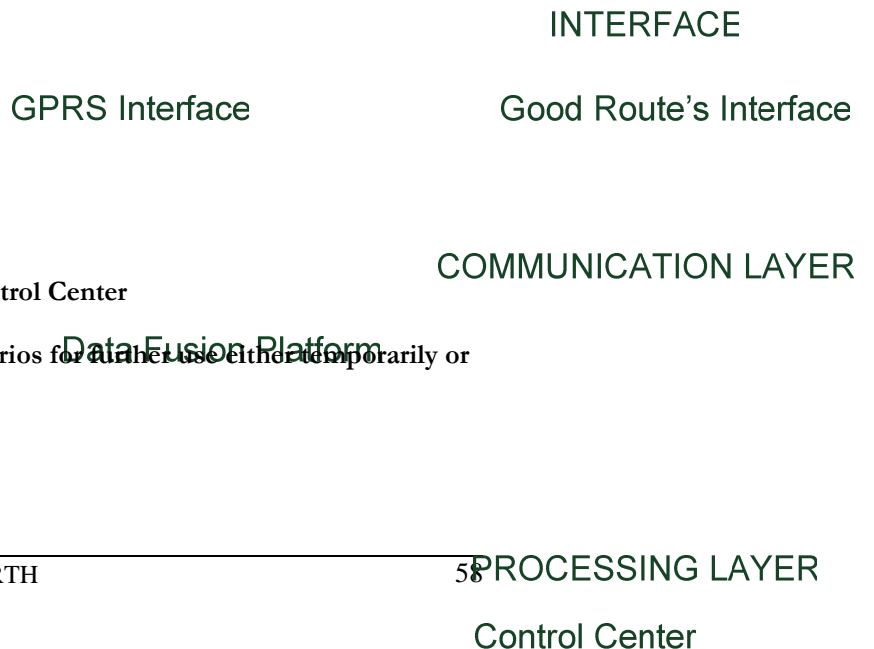

The completion of the route may have two different results:

- The planned route has been successfully followed and executed.
- The planned route has been changed during its development due to several reasons (e.g. UC3-UC4, UC5, etc.).

In both cases the LSS returns to the user the log of the route held and a comparative of the planned itinerary and the one actually held. The reasons of the deviation will be also mentioned. The Logistic Support System validates those data and stores them in their database and passes them to the Control Centre when a request is made. When an actor's request is made the LS System requests the necessary data from its repository and along with other data (user's data or other subsystem data) passes them to the appropriate subsystem for execution.

After this process the data of the routing would be erased from the system for security and data protection reasons.

The basic components of the LSS are described in more details in D4.2: "Control Centre and Logistic chain support modules".

At the Control Centre, a data fusion and information synthesis module is developed (A4.3). Its front end, through which the user can access the GOOD ROUTE system, is implemented in form of an Internet portal, and the respective HMI's for the different actors having different authorisation rights have been developed in A4.4 "Control Centre and Logistics Chain User Interface". The Data Fusion Module and the type of data that is used to generate new messages are described in D4.1: "Semantic Service Network and Control Centre data fusion algorithms", whereas the full storybook of the front end of the Control Centre is described in D4.2: "Control Centre and Logistic chain support modules".

The backend architecture of the GOOD ROUTE Control Centre is mainly consisting of two modules: the business logic that handles the general tasks like the profile and map management, and the data fusion, that takes care of all the incoming messages and their correct fusion and distribution.

The core of the GOOD ROUTE backend architecture is the business logic which is able to serve multiple tasks in the field of distributed Internet based Web services. It is based on a modular architecture. The servers are based on Windows COM technology and run on separate Windows server systems. In order to get maximum performance, they are developed using C++. The applications, as well as the pre-packaged application modules, are developed as Enterprise Java Beans (EJB). They run on standard J2EE application servers.

All components of this platform support web services by providing SOAP XML interfaces so that they can be easily linked to other enterprise applications or portals.

The user front-end can be developed with JSP/Servlet technology, Microsoft.NET, or other front-end technologies like stand-alone Java or Macromedia Flash or AJAX.

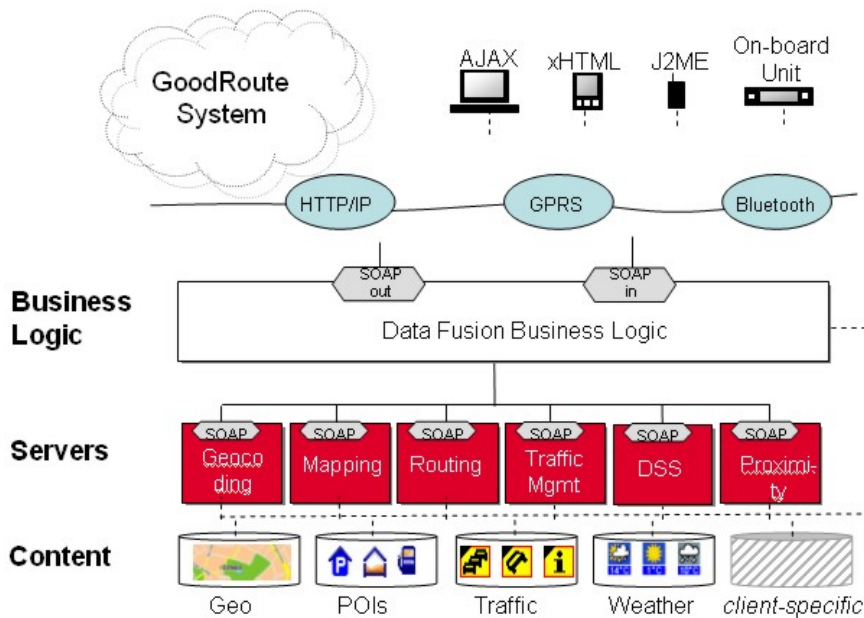

Figure 37: GOOD ROUTE system architecture backend overview.

The Control Centre front-end is actually the GOOD ROUTE Portal. The GOOD ROUTE Portal has the task of visualising the users' actions and to present the system results in a concise way at a central access point. The results that are presented to the user are selective according to his status and access rights. The main features of the portal are:

- User account management
- User profile management
- Vehicle monitoring and status display
- Route planning
- Data and parameter entry
- Display of dynamic data
- Implementation of the LSS module

The GOOD ROUTE HMI for all actors of the logistic chain has been developed by USTUTT, which in cooperation with PTV developed and implemented the screens and business logic. A concept was defined to manage the different user rights, profiles and user accounts. A data base was developed to host all the necessary parameters there are to be transferred between the Control Centre and the external modules. Whatever concerns Control Centre data fusion has been reported in D4.1: "Semantic Service Network and Control Centre data fusion algorithms", whereas the HMI's storybooks are provided in D4.2: "Control Centre and Logistics chain support modules".

The following table lists the main operations that can be done by a portal user. Some of the operations are reserved to the company that owns a truck, other operations are especially dedicated to operators in control rooms, for example a tunnel control room in

the test site of Italy or Switzerland. The system administrator is allowed to access the whole system, whereas the truck driver has only a very restricted access. This is due to the fact that route planning and event management is done by an operations department, whereas the driver of a truck just has to follow certain instructions. Thus it is for example possible for a dispatching company to create an account on the GOOD ROUTE portal, but the driver of this company is only allowed to see the planned route, or to trigger re-routing in case of a serious incident on his current route.

	Driver A, B, etc.	Truck Owner A, B, etc.	TMC A, B, etc.	Administrator
Create account		X	X	X
Delete account		X	X	X
Login	X	X	X	X
Change account		X	X	X
Plan a route	X	X		X
Change activation of driver route	X	X		X
Change activation of company routes		X		X
Change activation of all routes				X
Trigger re-routing	X	X		X
Change driver routes	X	X		X
Change company routes		X		X
Delete driver routes	X	X		X
Delete company routes		X		X
Monitor company trucks		X		X
Monitor all trucks			X	X
Monitor company routes		X		X
Monitor all routes			X	X
Enter (alert) messages in portal (to be sent to mobile device)			X	X
See logistic data per vehicle in portal		X	X	X
Change logistic data in portal		X		X
Login from Mobile to portal	X	X		X
Access portfolio		X		X

Table 3: User rights matrix.

The first interfaces developed were those ones for the logistic companies actors and the infrastructure operators (since the 2nd Year of the project). As a final step, following a user-centered design approach, USTUTT has conducted a qualitative evaluation of the logistic chain actors (logistics companies operators and infrastructure operators)

interfaces during the 3rd year of the project (for the infrastructure operators, 2 alternative mock-ups were developed and pre-evaluated, prior to the final usability tests), using representative test participants.

The usability tests have been conducted at the offices of the respective users, utilising a website-prototype made by USTUTT. 8 male dispatchers and 9 mail infrastructure operators participated. Optimisation potentials have been identified and realised for each interface, resulting in the final concept.

In addition, interfaces for the fire brigades, the police and the DG customers. (consignors and consignees) have been developed. The interfaces of the logistics chain, the fire brigades, the police and the customers together with the usability tests results have been reported in the updated D4.2: “Control Centre and Logistic Chain support modules”.

Finally, the GOOD ROUTE portal has been developed and configured for each demonstration site. It offers every user group (logistic company, driver, infrastructure operator, etc.) a set of needed functionalities, e.g. a logistic company needs to plan or to modify a route. Thereby it supports the complex workflow for planning, approving and monitoring DG vehicle operations.

A series of example screenshots is provided below. The full storybooks of the interfaces for all actors are provided in D4.2.

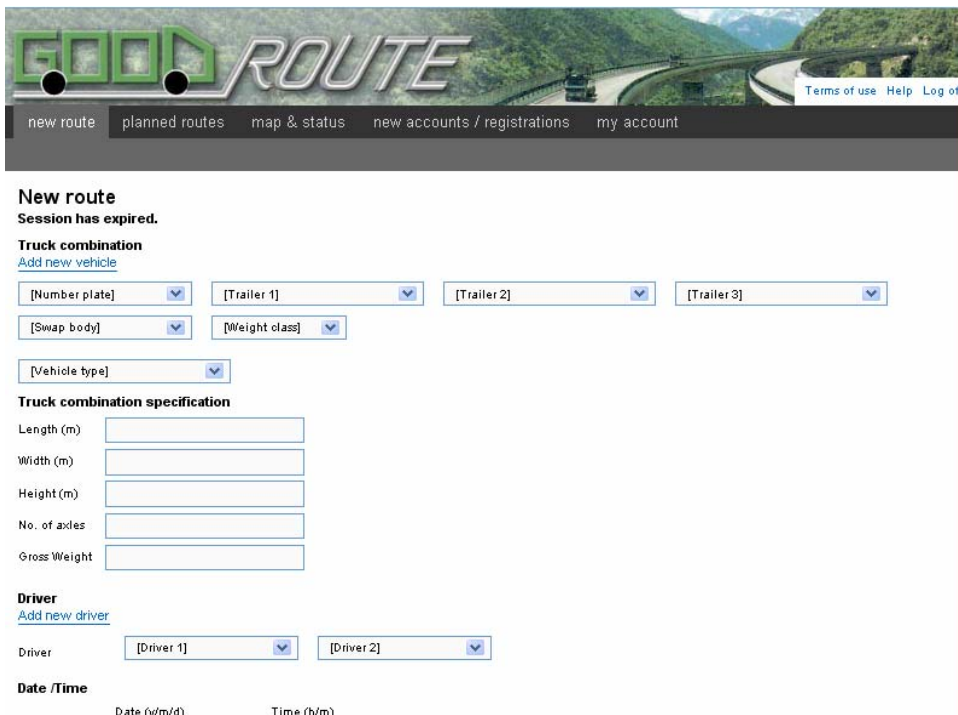

Figure 38: Screenshot from GOOD ROUTE portal – calculating a new route.

In the screen “planned routes” an overview is given of the planned, fished and routes which are performed in that moment.

There is also the possibility by pressing the corresponding button in last column of the table to modify, delete, view details or report a break down for the selected route.

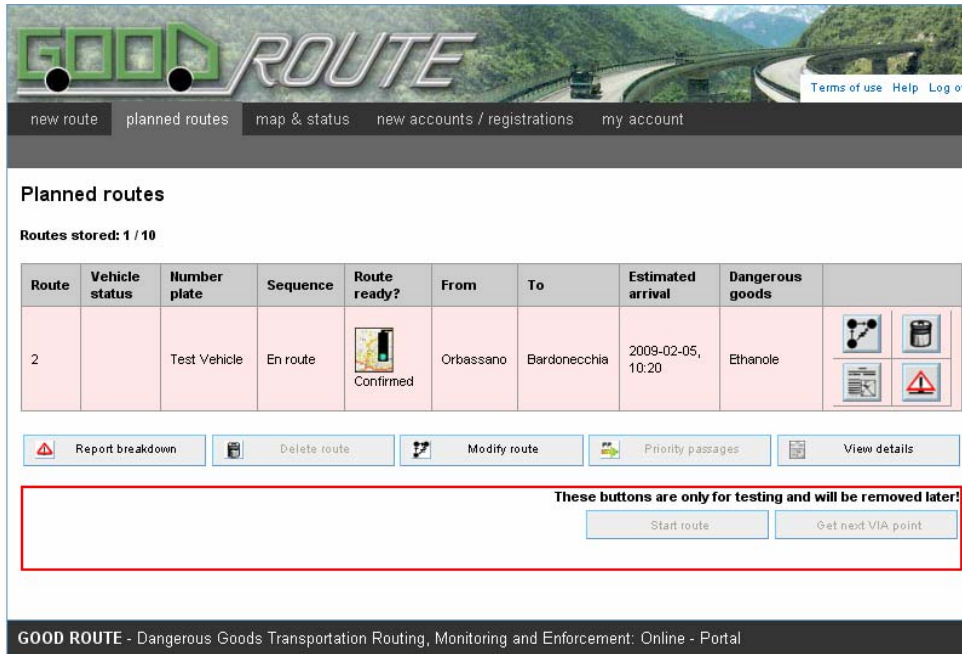

Figure 39: Screenshot from GOOD ROUTE – calculating a new route.

The screen “Map & Status” offers various information to the user. Once having selected a route to be displayed, the portal returns a map with route, traffic information and point of interest information. Several map features and functionalities are included e.g. zooming and sliding. Furthermore real-time status information of the vehicle and its load are displayed to the portal user.

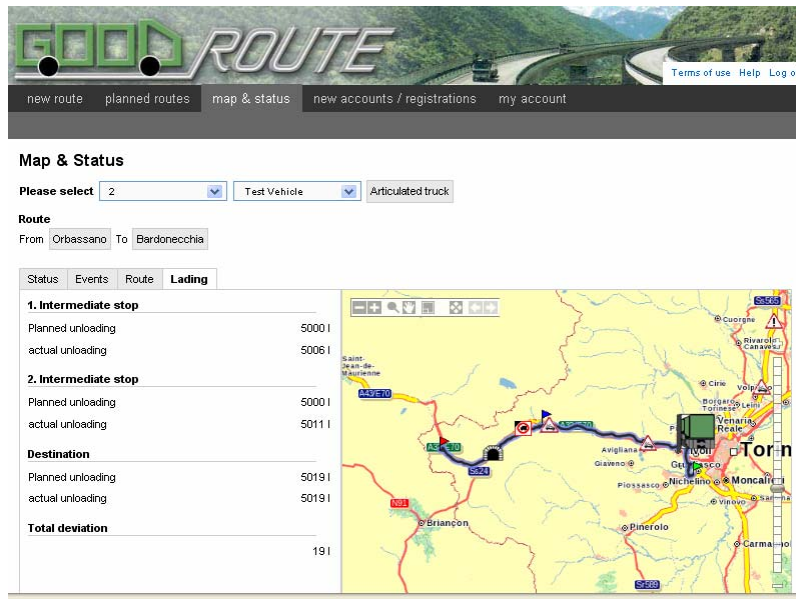

Figure 40: Screenshot from GOOD ROUTE – map & status view.

Being logged in as infrastructure, the first screen is an overview of the traffic situation. Approaching and passing through vehicles are listed with detailed information on vehicle and lading status.

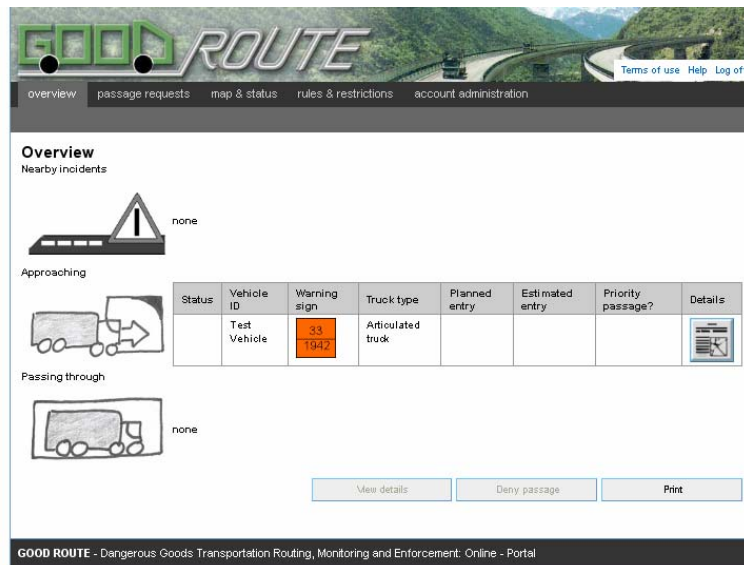

Figure 41: Screenshot from GOOD ROUTE – infrastructure overview view.

In the screen set passage requests, the infrastructure operator is able to grant or deny passage to a vehicle. Therefore, several information of the truck is provided within a list.

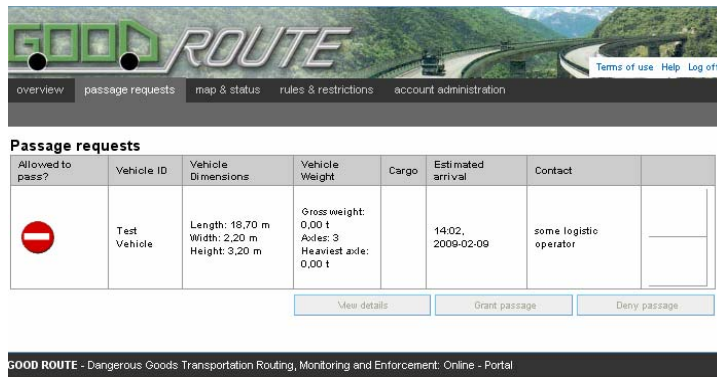

Figure 42: Screenshot from GOOD ROUTE – infrastructure – passage request view.

In the screen rules and restrictions, various restrictions can be set. One main feature is the setup of the status of the infrastructure, i.e. traffic congestions or tunnel closure can be simulated.

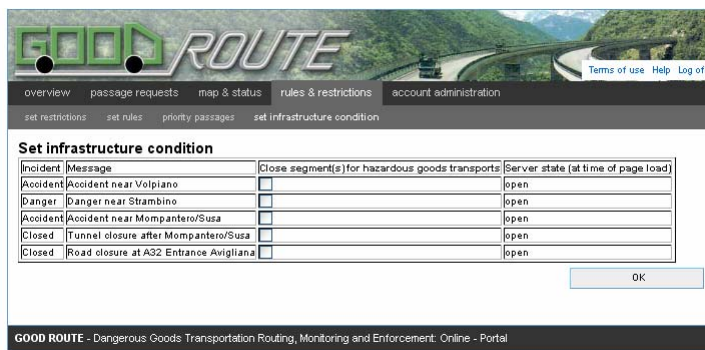

Figure 43: Screenshot from GOOD ROUTE – infrastructure – infrastructure condition view.

1.1.4.5. WP5: Enforcement System (UPM⁴) [Start: M3-End: M21]

Objectives

- To monitor key vehicle and cargo parameters and provide them telematically to a local enforcement mode, in order to support a reliable and cost-effective monitoring, Control and enforcement of dangerous goods vehicles.

Activities

- A5.1 Vehicle position and key parameters monitoring (CRF)
- A5.2 Telematic interface to local enforcement station (UPM)
- A5.3 Automatic intervention and enforcement (IVECO)

Work performed and end results

The main outcome of this WP has been the enforcement system of GOOD ROUTE. The initial specifications have been reported in D5.1: “Enforcement system specifications”, whereas the final module is presented in D5.2: “Enforcement system”.

The enforcement module deals with the automatic enforcement on behalf of the Police or the competent authority in case traffic or other type violation is detected, that presupposes the Police involvement in mitigation or at least notification and presence. The system provides an alarm to the enforcement for intervention, taking into consideration the values of key data (vehicle speed, vehicle and driver profile, type and amount of cargo, total weight per axle, etc.), compared to defined thresholds on local, regional (i.e. instantiated per infrastructure) level. The alarm is provided to a local or central checkpoint. The communication protocol between the local node and the OBU is part of the GOOD ROUTE Communication Protocol. This is an application level protocol based on XML messages which allow performing the several phases of the communication session (presented also analytically below, in WP6).

The XML Schema are unique for all the protocol messages, while in the vehicle to enforcement node telematic system only a subset of messages are used, in particular:

1. Open Session message
2. Close Session message
3. Confirmation message
4. Data Request message
5. Send Data message
6. Action Request message

An optional security layer is provided by an implementation of the RSA and AES algorithm. The initial hard key exchange phase of the RSA is carried out in the

⁴ Changed from SIEMENS.

identification phase, with the Open Session and Confirmation messages. Then the session key is used to encrypt all the following messages.

When the local node sends the End Session message, the communication session ends and the session key is destroyed.

In GOOD ROUTE project the communication between OBU and local node foresees to use the DSRC network layer. Regarding the communication over DSRC, different message formats has been defined, also based on the same data model.

This operation was necessary because the communication over DSRC has more restrictive requirements due to reduced communication times, which imposes to reduce the number of exchanged messages and to codify them into bytes and bits in order to compress messages instead of XML format.

The protocol is reduced to two messages:

- Send Data message
- Action Request message

From the point of view of the local node, nothing changes, because the communication with the OBU is managed by a specific entity, the communication gateway, which “virtualises” the communication via DSRC and emulates the GOOD ROUTE protocol in order to grant interoperability between different network entities.

In order to perform the communication between the local node and the vehicle, communication modules have to be developed and deployed at both entities. Their aim is to implement the protocol, building and sending messages, as well as receiving and parsing them. Communication modules include the software modules which handle the communication and the hardware modules which handle the wireless transmission. The wireless transmission technology chosen for this task is DSRC.

DSRC module is a communication module which implements the 5.8GHz DSRC standard. The module is composed by three different components: a control card, which implements the control logic, a DSR transceiver, able to transmit and receive data through 5.8GHz radio band and the antenna, which determines the intensity and the shape of the emission lobes of the radio signal.

The DSRC module can receive input from and produce output to a serial port (RS232) or the vehicle’s BUS CAN define acronyms; in addition it can also receive input from analogical sensors.

DSRC module protocol provides security features only by means of identification; the master / slave identity number is checked against a mask to verify the identity. Any other security features, including data encryption or a stronger identification based on RSA public / private keys has to be implemented outside in a higher level.

The maximum payload which is transmitted in every packet is 16 bytes, so that longer messages have to be split at the origin and reassembled at the destination.

The local node is an autonomous processing unit with communication capabilities. It is provided with two communication modules, in order to transmit and receive data to and from vehicles and the control centre.

The module which manages communications with the vehicles’ OBU is the one able to send and receive messages, implementing this way the protocol.

The principal tasks of this module are:

- To receive and to parse message from the OBU, containing vehicle's parameters, and to pass them to the data analysis module.
- To send to the OBU messages generated by the data analysis module; they can be requests for subsets of parameters or requests for actions.
- To implement the optional security features, represented by the implementation of the RSA and AES algorithms.

The enforcement module is intended to be used both for enforcement infrastructure, installing the local node in the edge of the streets before strategic points as bridges, tunnels or the frontier of countries, as for mobile enforcement, installed over a police cup in order to check vehicles by a car-to-car connection.

After the truck's check, if an alarm has occurred, the Local Node unit sends the information to the check point, via GPRS (or UMTS) connection, and inform it about check site's coordinates and type of alarm.

The Central checkpoint is to be imagined as a Web service, which processes information including input from users like infrastructure operators.

The Local Node's business logic is ADR-based ("European Agreement concerning the International Carriage of Dangerous Goods by Road") and can be updated via messages from the Central checkpoint.

The following figures provide an overview of the enforcement module operation and architecture.

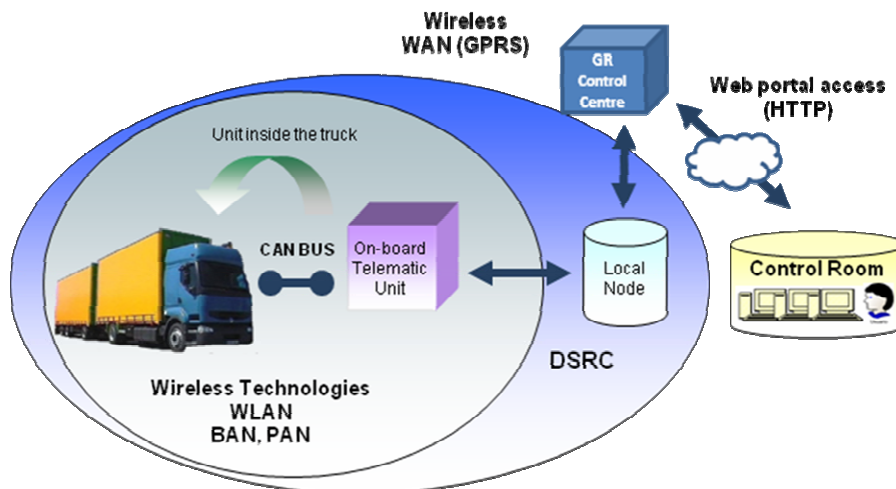

Figure 44: Enforcement System Overview.

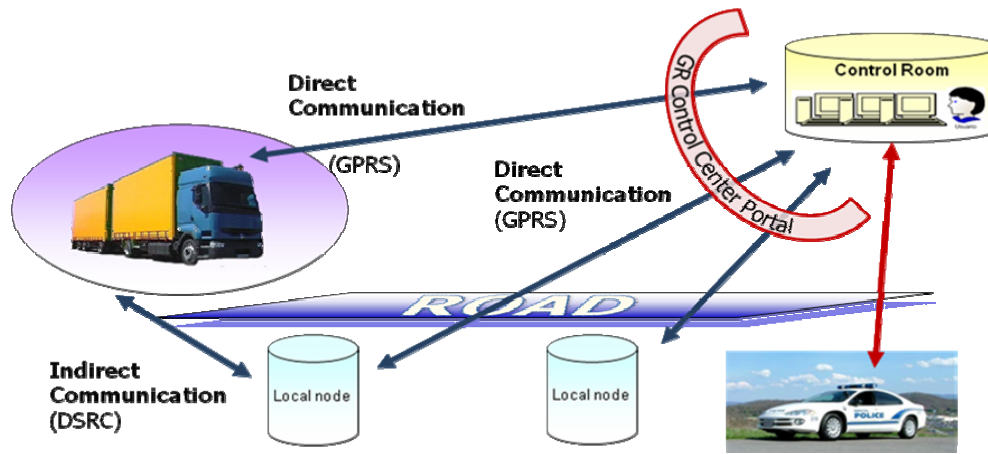

Figure 45: Enforcement System Architecture Overview.

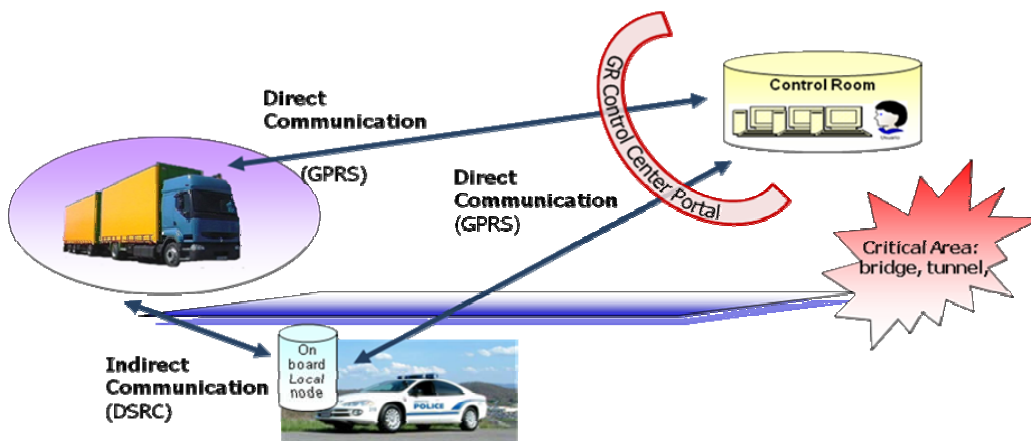

Figure 46: Police in the Enforcement System Network.

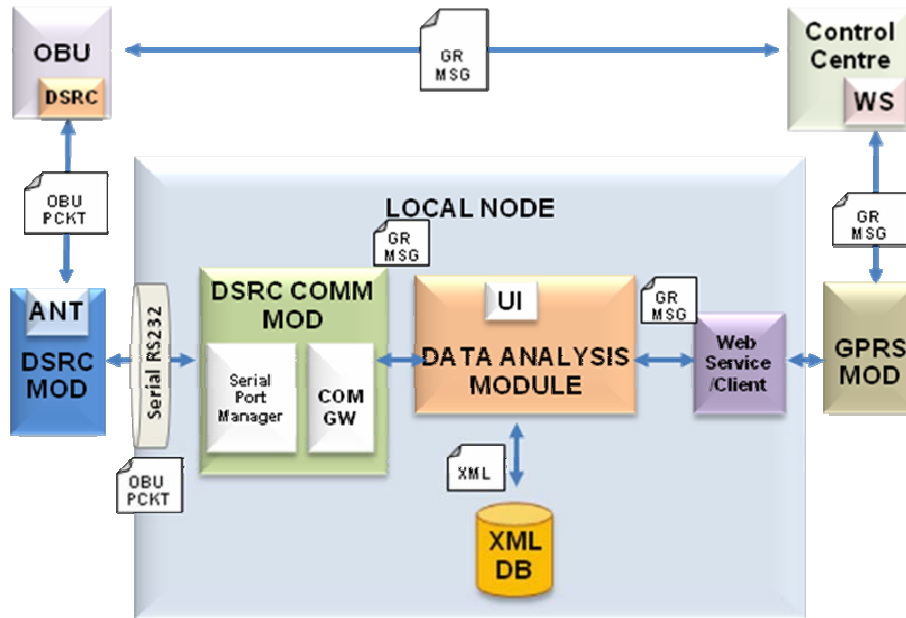

Figure 47: Local Node internal Architecture.

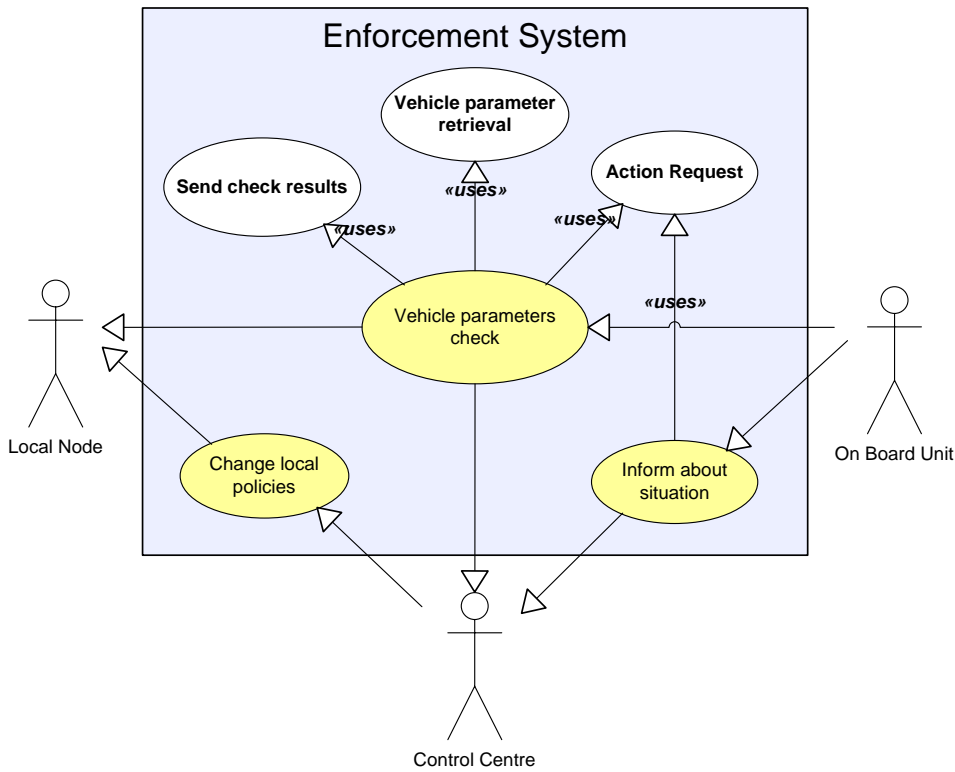

Figure 48: Enforcement System use cases.

1.1.4.6. WP6: Cooperative System Integration (IVECO) [Start: M6-End: M26]

Objectives

- To define a robust and interoperable System Architecture for GOOD ROUTE, that leads to a system that abides to all existing and emerging standards in the area and is modular enough to incorporate different technological elements and solutions.
- To define and develop an architecture that ensures security and user privacy through the global system.
- To develop methods that provide encryptions mechanisms over selected communication channels.
- To guarantee the security and user privacy through the global system.
- To integrate the GOOD ROUTE elements at each Pilot site.
- To built a vehicle demonstrator, to assess the GOOD ROUTE functionalities.

Activities

A6.1 System architecture (ICCS)

A6.2 Semantic Interoperability (UPM)

A6.3 Security and information reliability aspects (TID)

A6.4 System integration (CERTH/ITI)

A6.5 Vehicle Demonstrators development (IVECO)

Work performed and end results

The first task of this WP was to define the GOOD ROUTE system architecture (quite early in the project). The relevant task for that was A6.1: “System Architecture”.

National systems architectures have been investigated (i.e. Artist: Italian Architecture for transportation systems), whereas the CVIS and the SAFESPOT project architectures have been communicated to be taken into consideration into the system architecture. In addition, an investigation has been carried out, focusing on the technologies which will be used for the communication between the modules of the whole GOOD ROUTE system by UPM leading to the definition of the telecom architecture incorporated in the system architecture.

GOOD ROUTE system architecture development has been based on WP1 use cases and scenarios of use (may be found in D1.1: “Scenarios of use and dangerous goods ontological framework”), which do not only describe the situations the system will handle, but in addition, they also create a clear picture of the functional concept of the GOOD ROUTE system. The decomposition of the GOOD ROUTE Use Cases according to the individual requirements of all involved stakeholders has been the first major milestone of the work held in this WP and is documented in GOOD ROUTE D6.1: “System architecture, including interoperability and security aspects”.

The system architecture had been drafted since the first year of GOOD ROUTE and before reaching its final version, it has been revised several times. D6.1 presents the

architecture principles for the GOOD ROUTE system, together with the most important components of the GOOD ROUTE architecture, namely the Decision Support System (DSS) which is the core of the GOOD ROUTE system as it provides the Dangerous Goods Vehicles with optimal routing guidance taking into account a broad array of socioeconomic factors and the Logistic Support System (LSS) that complements the DSS by proposing the minimum risk routing and assists the companies carrying dangerous goods in their routing and delivery procedures.

GOOD ROUTE provides a flexible and modular architecture which allows different implementations corresponding to different business cases. The design principles are chosen in such a way, so that existing components do not have to be changed principally but only extended by integrating GOOD ROUTE specific functionalities or additional, new applications.

The following figure shows the GOOD ROUTE context diagram which is a description of the main input and output of GOOD ROUTE applications and the external environment.

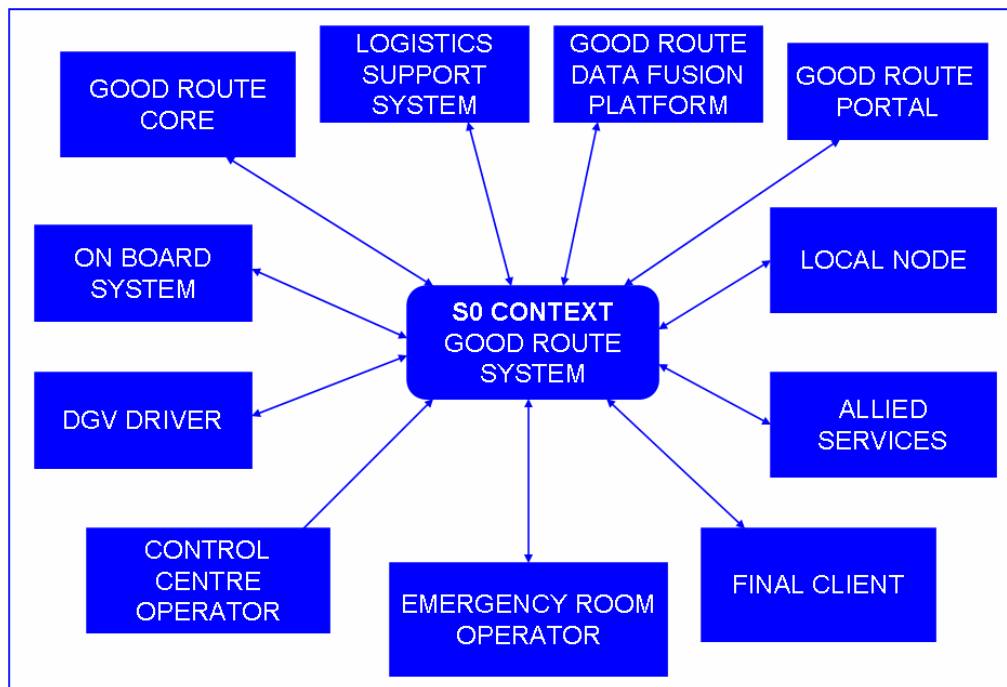

Figure 49: GOOD ROUTE General Context Diagram.

The terminators that constitute the boundary of the GOOD ROUTE system are the following:

1. On Board System;
2. GOOD ROUTE Core System;
3. Logistics Support System;
4. GOOD ROUTE Portal and Data Fusion Platform (DFP);

5. Local Node;
6. DGV Driver;
7. Control Centre Operator;
8. Enterprise Room Operator;
9. Final Client;
10. Allied services.

The subsystems that compose the GOOD ROUTE system are presented in the following diagram:

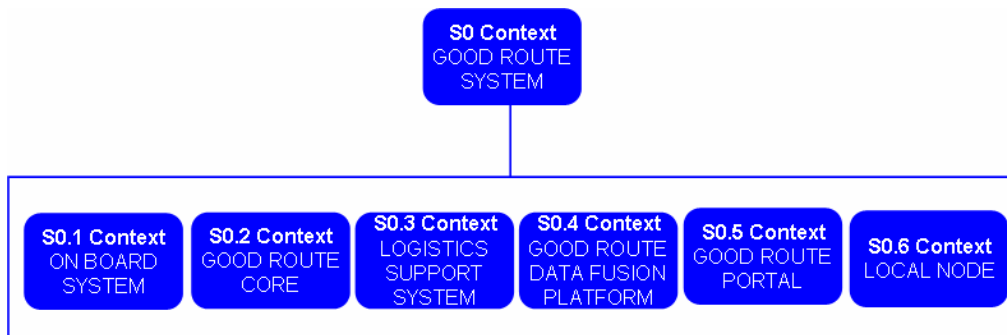

Figure 50: GOOD ROUTE sub-systems.

A representation of the GOOD ROUTE overall system architecture is given in the following figure:

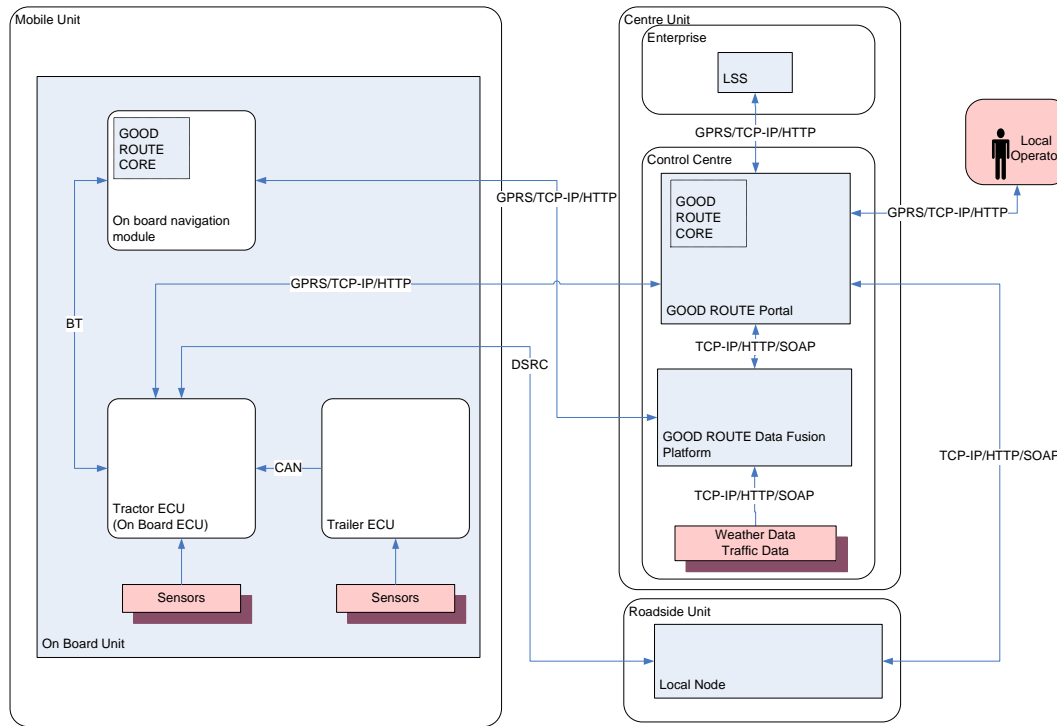

Figure 51: GOOD ROUTE architecture.

UML diagrams have been developed for all Use Cases determined in WP1.

Semantic interoperability in GOOD ROUTE system was required to enable the exchange and the integration of data between heterogeneous information systems and their data model and repositories. Semantic interoperability aspects in GOOD ROUTE were dealt in A6.2: “Semantic Interoperability”.

The state of the art of data exchange in the traffic and transportation domain is represented by DATEX standard. DATEX was designed and developed as a traffic and travel data exchange mechanism by a European task force set up to standardise the interface between traffic control and information centres. In the road sector, the DATEX standard was developed for information exchange between traffic management centres and constitutes the reference for applications that have been developed in the last 10 years.

In GOOD ROUTE system, DATEX II was used as a “common data model and dictionary and exchange protocol” and served as a starting point from which to take inspiration. The protocol defined in GOOD ROUTE is a high level protocol based on XML messages which carry information to manage the protocol and a payload.

The XML Schema has been designed from scratch without the initial UML model and the conversion phase, as GOOD ROUTE data model was already defined in the ontologies described in deliverable D1.1 (see WP1).

DATEX II defines a service oriented protocol to enable the provision of information in a server/client paradigm. The client subscribes to a certain service to receive information in several modalities. Every DATEX II message is then composed by two parts:

- The *exchange* section, describing the protocol;
- The *payloadPublication* section, containing the data.

In the GOOD ROUTE communication protocol the same general structure was followed rearranging and extending the elements for the payload section, and completely redesigning the exchange section. Such changes were necessary because of the different necessities of the communication between enforcement entities, which is more near to a peer to peer model than a server/client one.

As a result, communication protocol messages are divided in two sections:

- The *exchange* section, which describes the protocol, identifying the message type, the sender, the recipient and other information;
- The *payload* section, which, depending on the message type, is more or less extended and can contain several kind of information.

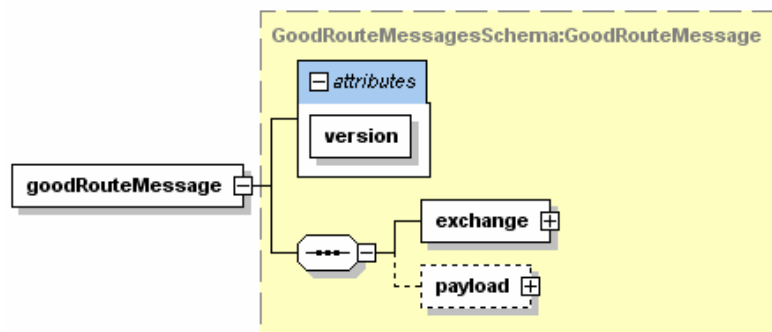

Figure 52: GOOD ROUTE message Schema's main structure.

In order to comply with the protection of individuals directives of the European parliament, and to increase user acceptance of the GOOD ROUTE framework, it was mandatory to implement a strong security service to protect the collected private data from companies and trucks and organize the access to contents (e.g. the decision support system will make use of company data that should not be accessible by other actors of the system). Security aspects in GOOD ROUTE were dealt in the context of A6.3: "Security and information reliability aspects".

A survey on the state of the art was performed describing security features of the communication technologies and extra security technologies that can be integrated in the system. Based on requirements collected on the first stages of the project, security aspects to be applied in the project and future adaptations were defined.

In the next figure, the GOOD ROUTE communications architecture is presented. At the bottom of the image, we can see three additional elements included to implement additional security to the system: the AES encryption algorithm, a symbol referencing the WS-Security, and an icon illustrating a centralized security architecture.

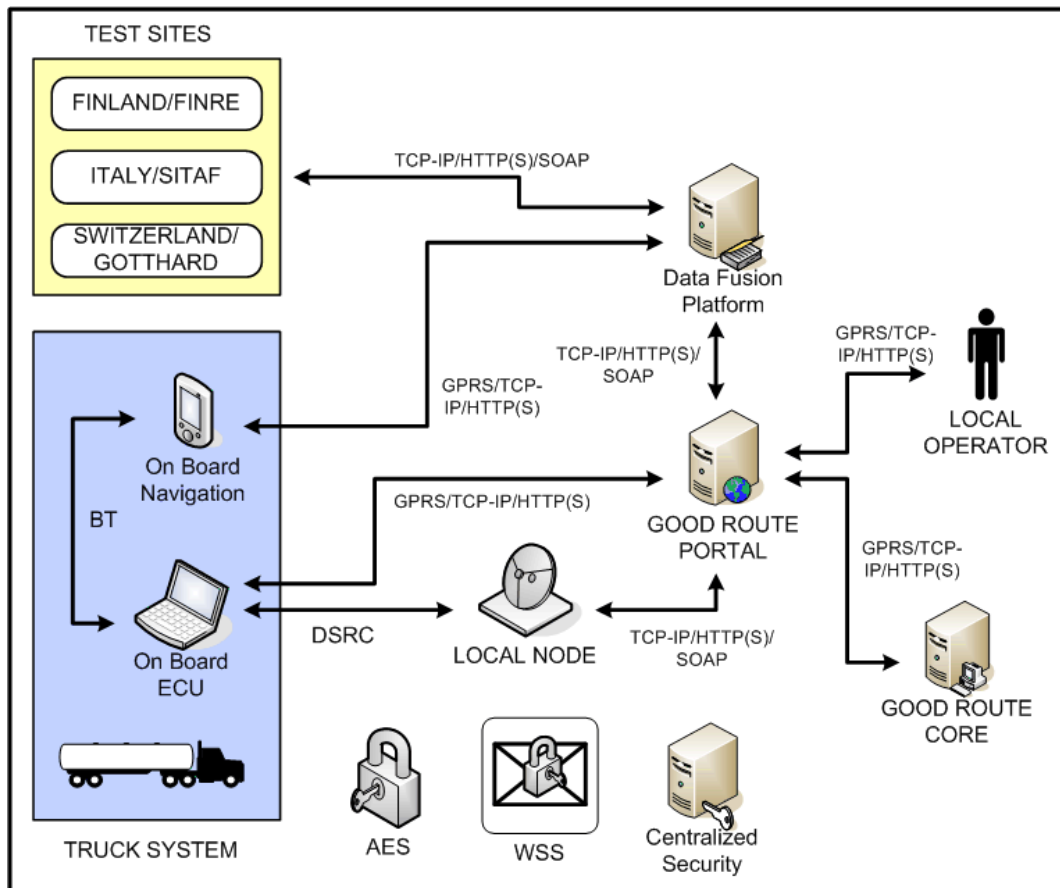

Figure 53: GOOD ROUTE communications architecture.

Regarding the figure we can see that most of the wireless communications are done via GPRS, which is secure; for example, the communication between the OBU and the Control Centre, with its security functionalities (performing authentication and ciphering setting procedures based on the same algorithms, keys and criteria as in existing GSM, also using a new ciphering algorithm optimized for packet data transmission) is inaccessible for extern agents. All the communications, both wired and wireless have been designed over http, but the migration to https is possible, which is based on SSL.

The three added elements to extend the security are:

- **AES:** The AES encryption algorithm has been finally adopted due to its higher performance in front of the other possibilities considered. Sensitive data in the Control Center and the On Board Unit will be encrypted with this module before its storage. Optionally it could be used to encrypt the information before its transmission between the different modules increasing the security (i.e. before the transmission via DSRC between the OBU and the Local Node, but this proprietary technology implements its own security, so it is not necessary).
- **Webservices:** The webservices have implemented different levels of security to exchange information. In case of sensitive information, the specification WS-Security (WS-Security describes enhancements to SOAP messaging to provide

quality of protection through message integrity, message confidentiality, and single message authentication) is adopted.

- **Centralized Security:** A centralized security system is suited for GOOD ROUTE, and for this reason Kerberos features have been described. During the integration and experimentation phases, it was not planned to implement and install any kind of security protocol to supervise the whole network authenticating all its nodes, users and components, but in the future this option must be adopted, taking into account diverse initiatives like SeVeCom.
- **GOOD ROUTE Portal:** It was mandatory to implement a strong security service to protect the collected private data from companies and trucks and organize the access to contents (e.g. the decision support system will make use of company data that should not be accessible by other actors of the system). The access to sensitive data was restricted, based on user-defined policies and automatically classify real-time information based on its nature. For this reason different kinds of actors have been implemented, restricting the accessible information for each class. All these users have defined along the project (DGV driver, Control Center Operator, Enterprise Room Operator, Final Client, Allied Service), and their features and accessibility is defined in D4.1 “Semantic Service Network and Data Fusion Algorithms”.

According to GOOD ROUTE, the technologies and add-ons adopted were secure enough for the demonstration of the system. For future wide implementations, other solutions must be adopted, in order to control large scale systems with significant number of users that increment the number of communications and risks.

The semantic interoperability and security aspects considered in GOOD ROUTE have been fully reported in D6.1: “System architecture, including interoperability and security aspects”. D6.1 closes with a Risk Assessment performed early in the project, on the basis of the FMEA methodology.

This analysis involved various factors of each safety-security issue: severity, occurrence probability, detectability and recoverability, not only for technical risk, but also for behavioural, legal and organizational related risks. Behavioural risks are related to the users’ behaviour, regarding their interaction with the system, concentrating on the possible wrong moves or reactions they might perform. Legal risks include the risks that will arise if the system is not compliant with the legislation of the country. Finally, by the term organizational related risks, the risks involved within the organization structure of the service chain. The overall process followed is depicted below:

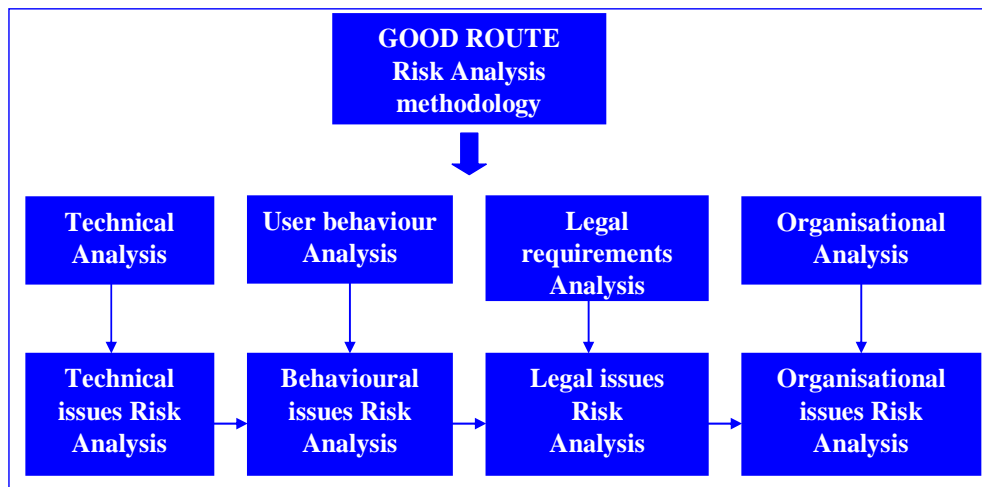

Figure 54: Risk analysis process.

Performing the FMEA started with defining the system to be analysed, constructing a block diagram and finally identifying all potential items and interface failure modes. A tabular format was used to document the FMEA which is based on various columns, including name or item, problem short description, severity, occurrence, detectability, recoverability and overall risk rates, effect of failure and possible actions to reduce failure rate or effects.

Technical, behavioural and legal/organisational risks were identified and strategies for reducing (mitigating) the identified risks were considered by the GOOD ROUTE consortium, together with the probability of their success.

The majority of the risks identified can be compensated at a relatively small cost or in some other cases, an achievable solution may be possible at reasonable cost, or a reasonable solution is available at modest cost. In those cases that the technical, behavioural, organisational or even legal risk, can potentially create a severe problem to the GOOD ROUTE system, one can see that the mitigation possibility is high, which means that the GOOD ROUTE consortium can address the specific problem at a relatively small cost. Moreover, the majority of the moderate problems can also be faced at a relatively small cost, while for some of them an achievable solution may be possible at reasonable cost, or a reasonable solution is available at modest cost.

The analysis performed shows that as GOOD ROUTE has ambitious goals, matching new technological developments with a complex problem has inherently high risk. This is compensated within GOOD ROUTE by the high previous expertise in this area of several of its partners, their multidisciplinary and the Consortium's width.

The integration of the GOOD ROUTE system and its instantiation at the three Pilots sites has been held in A6.4: "System Integration".

In order to accomplish this task the complete system has been treated as a set of individual components-modules, where only the information flow between them is of interest. For this purpose a number of interfaces has been clearly defined and developed. Each one of these interfaces consists of one or more web services modules running over

the telecommunications layer. The main objective of the integration process was to define the rules and the architecture for the information flow in order to provide homogenous, robust and flexible system despite of the underlying technology used in every core module and sub-module of the system. The success of the integration is a single system which has its core modules distributed in three countries (Greece, Germany, Spain), that would be used for testing in the three Pilot Sites (Italy, Switzerland, Finland) with minor interventions, like the Enforcement Node placement. The GOOD ROUTE system consists of various components from different vendors, which are illustrated in the following figure:

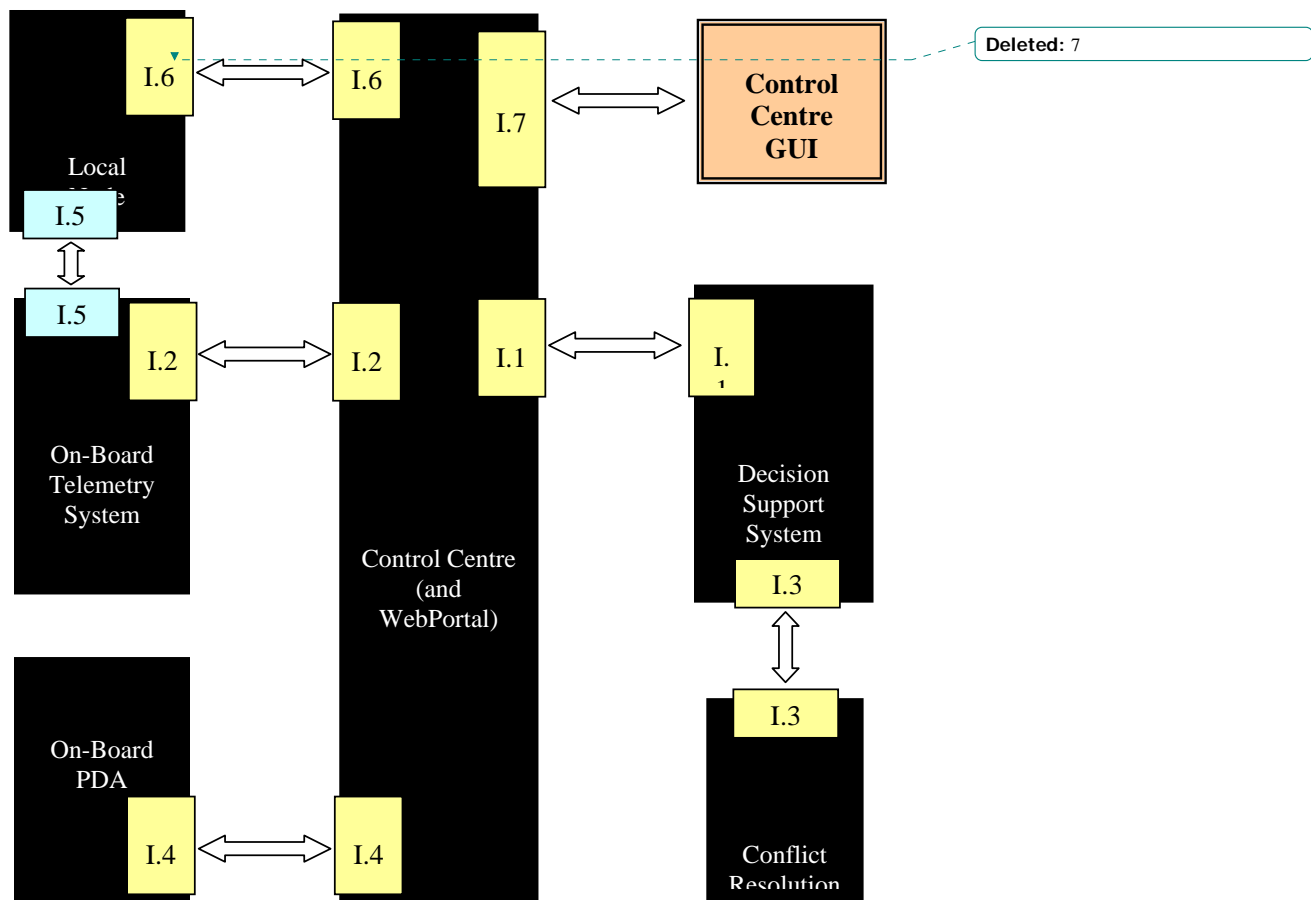

Figure 55: GOOD ROUTE system overview and interfaces between the components.

The interfaces between the core modules of the GOOD ROUTE system are identified and reported in D6.2: “GOOD ROUTE system integrated at the three test sites”. In short, the following interfaces are depicted in Figure 58:

- I.1 Web portal to Decision support system interface:
Interface for web portal to contact the DSS in order to estimate a new route.
- I.2 Control Centre to On-Board Telematics System interface:
Three calls are supported:
 1. *Tracking*, where the vehicle transmits data gathered by various sensors

2. *Statistics*, where the vehicle transmits general own characteristics (e.g. height, weight, etc.)
 3. *Alarms*, where alarms from local node are transmitted to the control centre.
- I.3 Decision Support System to Conflict Resolution Interface:
Interface to accept or decline the optimal route estimated by the DSS module.
- I.4 Control Centre to On-Board PDA interface:
This interface is used to display navigation information, messages, alarms to the driver on his trip and handles all the interaction of the driver with the GOOD ROUTE system for route and passage configuration.
- I.5 OBU to Local Node interface:
This interface is used to interchange data between the OBU and the local node. For instance, data can contain information for the truck and its cargo.
- I.6 Local Node to Web Portal interface:
The local node uploads the data collected from the vehicles using this interface. Also the configuration data for the enforcement policies can be downloaded using this interface.
- I.7 GUI of the Control Centre (Web Portal):
Web front-end that interconnects operators, users and logistic support users with the GOOD ROUTE Control Centre system.

The integration of the GOOD ROUTE system can be divided into two levels: a) the telecommunications level and b) the information level. The telecommunications level includes all the network devices and networking protocols required to physically interconnect and transfer the data between the different subsystems. At the information level, the protocol that is used to exchange meaningful information between the heterogeneous sub-systems that compose GOOD ROUTE is described. This protocol defines the data model, the messages, and the parameters exchanged and in combination with the communication protocols provides a transparent interface between the different sub-systems and modules.

Three pilot sites were chosen to test, validate and demonstrate GOOD ROUTE. These are Finnish Road Enterprise/FINRE located at Finland between Turku and Helsinki, Gotthard Road Tunnel/GST located at Switzerland and Frejus/SITAF tunnel located at Bardonnechia in Italy. As aforementioned, GOOD ROUTE consists of a number of distinct and autonomous core modules and sub-systems interconnected and integrated by a number of interfaces, in a manner that absorbs the network and operating systems heterogeneity. This architecture and integration strategy gives the flexibility to distribute the various sub-systems in distant places, without any degradation in system's performance and quality of service. The configuration that was used for the Pilot sites tests is as follows: the Web Portal was installed at PTV/Germany, the DSS at CERTH-ITI/Greece and the Conflict Resolution at TID/Spain. The main reason for the chosen configuration is that during the Pilots testing, technicians from each Partner site that have been responsible for the corresponding module, would have the opportunity to monitor, evaluate and optimize their modules performance at run-time. The only sub-system that required special treatment in each Pilot site is the Local Node. Since Local

Node utilizes short range communications in order to exchange data with the vehicle demonstrator, it requires visual contact with the truck. So, before the start of testing at each Pilot site, the Local Node was transferred and placed in a proper location within truck's route.

These locations have been chosen and are situated in the road's board in observance with European road's signs distance rules. Local Node needed to be positioned in a box of a cabin, containing the Local Node System, the DSRC module and the DSRC antenna. Local Node communicated with the Control Centre with a GPRS or UMTS modem. Local Node cabin needed also to be projected to be immune by any kind of bad weather that could compromise the communication or any hardware module.

It is obvious that GOOD ROUTE is a fairly complicated system which combines many different technologies in software, middleware and hardware level. The objective of the integration process was to absorb this heterogeneity and to transform GOOD ROUTE into a robust but also a flexible system. Based on the defined system architecture, the methodology followed in order to accomplish this task, was first to define TCP/IP as the communication network layer and then to develop a number of interfaces between the different modules based on web-services technology. This approach has the following main advantages:

- TCP/IP protocols hides the underlying communication network transmission technology which can be wired or wireless, local or remote.
- Web Services permits GOOD ROUTE modules to exchange data regardless of the operating system and hardware platform used.
- GOOD ROUTE can be implemented as a distributed or a concentrated system as well according to the application needs with minimum costs and complexity.
- System's modularity permits easy maintenance, administration and expandability.

Within GOOD ROUTE, there was only one truck demonstrator developed, by IVECO, which, for the needs of the Pilots, travelled around Europe from one site to another. The tractor and trailer OBU functionalities have been described above, in WP3.

The system architecture defined in WP3 took into account the feasibility aspects of the demonstrator integration. A concrete methodology for automotive systems integration does not exist and, as such, the procedures followed in GOOD ROYTE are mainly based on existing practices; therefore the integration work held in the context of A6.5: "Vehicle Demonstrators development" can be summarized in the following steps:

- Designing cabling schemes for the connections of all the devices that have to be integrated;
- Preparing required harnesses;
- Install harnesses and connecting devices in the vehicle;
- Performing electrical tests;
- Performing functional tests;
- Performing field validation tests (prior to the Pilots).

In order to start the vehicle integration, the OEM architecture has been analyzed and schemes have been designed for the connection between the existing original vehicle subsystems and the ones added for the project (see WP3). After the cables connections had been selected, the harness has been produced and integrated in the vehicle.

The first subsystem that was integrated was the tractor OBU, because it represents the focal node of the GOOD ROUTE vehicle application. The DSRC system and the trailer emulator have been developed autonomously and then integrated in the vehicle. The last system that was integrated was the navigation system; it is independent from the OBU and it needs only power supply by the vehicle, through a cable connected to the standard vehicle lighter interface.



Figure 56: GOOD ROUTE IVECO Stralis.



Figure 57: Tractor OBU integrated in truck cabin.

The electrical validation activity was oriented to validate the harnesses designed and installed in the vehicle and then the system components electrical integration into the vehicle. All the electrical contacts have been verified with a tester while the engine of the vehicle was off. The CAN messages availability has been verified with the engine on and the vehicle stopped. Different trials have been carried out with the vehicle in motion in paved roads and driving conditions to check the solidity of the wiring and of the internal integration. All the connections proved to be robust. The Functional validation consisted primarily of separate validation of the main functionalities of the GOOD ROUTE vehicle systems. Both the GOOD ROUTE CAN bus and the vehicle CAN network have

been constantly monitored by means of dedicated tools to verify the right flow of messages between all the modules. This validation has been performed with the engine on and the vehicle stopped. After having validated the single system components, the overall functionalities have been tested in a testing circuit while the vehicle was moving. In all the tests, the vehicle GOOD ROUTE functionalities were positively performed, although the DSRC device, used for the enforcement use case, seemed to be rather sensible to antennas positions.

All types of tests outlined above, although part of the integration phase, have been described and held in the context of WP3.

After these validation tests the conclusion was that the vehicle demonstrator fulfils the GOOD ROUTE functionalities expected from the truck. The OBU, although being a prototype, operates correctly and the developed tool seems to be quite robust. It doesn't require too much driver interactions because all the developed functionalities are almost automatic.

More effort should be dedicated to analyze data acquired from the vehicle and from the trailer during real on road driving, in order to tailor algorithms more efficiently and with more precision. Another aspect that should be considered for the future is the integration with a vehicle to vehicle communication system, as for example the one that will be developed within the CVIS EU IP project. Because the CVIS router box for wireless communication was still on testing (while GOOD ROUTE integration was taking place), it was not possible to be integrated in the GOOD ROUTE vehicle architecture. The DSRC solution that has been adopted in the GOOD ROUTE project to perform vehicle to local node communication needs some development and specially more tests in order to be used for V2V applications. However, the possibility to use the GOOD ROUTE DSRC system in order to communicate to a navigation client located in a different vehicle will be investigated. A tool with V2V communication for enforcement seems to be a promising area for highway patrols applications

The GOOD ROUTE truck demonstrator was used for the GOOD ROUTE final trials with users (see WP7 below), in order to systemically validate the project concept and target use cases in real life conditions. For this reason, the demonstrator travelled in the area around Turin to Frejus tunnel, then to Switzerland and Frejus tunnel and finally to the Finnish highways.

The system architecture of the system is described in D6.1: "System architecture, including interoperability and security interfaces and routes", which also covers semantic interoperability and security aspects, the overall system integration is fully covered in D6.2: "GOOD ROYTE system integrated at the three sites", whereas the integrated vehicle demonstrator is described in D6.3: "GOOD ROUTE vehicle demonstrator".

1.1.4.7. WP7: Pilot testing (FINRE) [Start: M1-End: M34]

Objectives

- To define evaluation methods and assessment criteria for the project.
- To test the reliability and usability of the selected implementation scenarios and ontologies of WP1.
- To test the reliability and usability of the developed new simulation models and the Minimum Risk Route Guidance System of WP2.
- To provide the necessary evidence to propose new guidelines on technical/functional and training level towards the introduction of new standards of WP8.

Activities

A7.1 Pilot plans (CERTH/HIT)

A7.2 Pilot realisation (FINRE)

A7.3 Pilot results consolidation (CERTH/HIT)

Work performed and end results

The overall evaluation framework for GOOD ROUTE was defined in the context of A7.1: “Pilot plans”.

The evaluation scenarios, upon which the GOOD ROUTE system would be evaluated by each foreseen Pilot conductor (FINRE, SITAF, GST) with IVECO demonstrator were determined since the first year of the project. The evaluation scenarios formulated were based on WP1 Use Cases. A short description of the IVECO demonstrator and the Pilot sites venues, operation and available facilities and equipment are also provided in D7.1. The Pilot plans were defined for each test site with regard to the type and number of users that will participate, the type of roads that will be employed for the Pilots, the POI's included, the specific evaluation scenarios that will be tested in each and finally the scheduled time-plan for the trials. In addition, the high-level objectives of the evaluation and the type of the evaluations methods identified as applicable for the GOOD ROUTE Pilots are described. A pre-assessment of the GOOD ROUTE system, upon the expected impacts was performed, whereas concerning the experimental objectives a detailed study design per selected type of assessment was provided.

The GOOD ROUTE Pilot evaluation framework developed for the evaluation of the GOOD ROUTE system has been prepared on the basis of the “Guidebook for Assessment of Transport Telematics Applications” (Zhang et al., 1998) and the “Checklist for Preparing a Validation Plan” (Maltby et al., 1998), both developed in the context of the CONVERGE project. However, all needed adaptations were realised to meet the needs of the GOOD ROUTE project.

The methodology followed is depicted in the following figure.

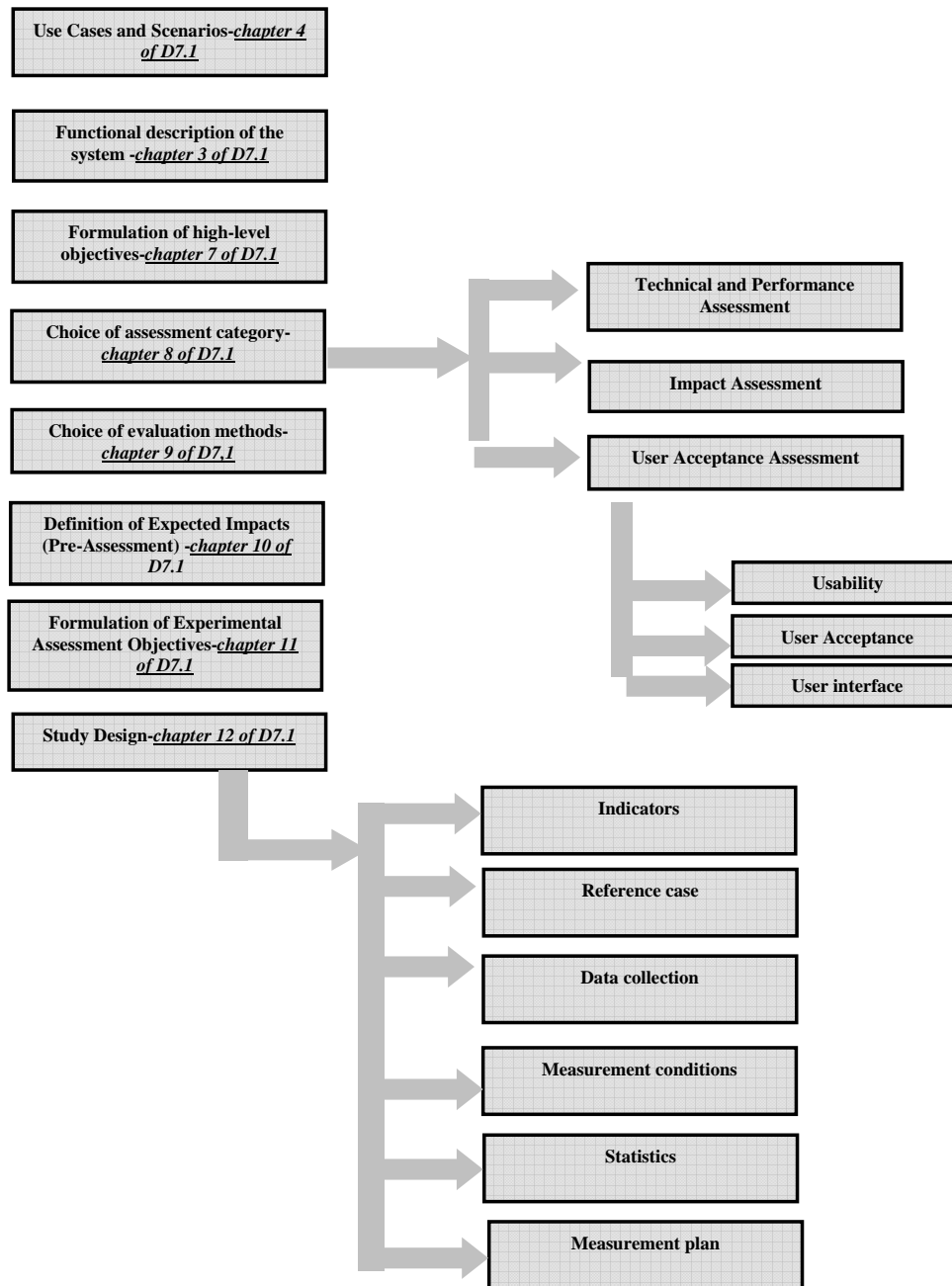

Figure 58: Validation Approach of GOOD ROUTE (modified, following Zhang et al., 1998).

The GOOD ROUTE three Pilot sites were GST (in the Gotthard tunnel), FINRE (now called DESTIA) (Finnish highways with bridges) and SITAF (in Frejus tunnel). In all cases, the tests were conducted with the IVECO truck demonstrator. As it has been agreed and aforementioned, the trailer was emulated and the cargo emulated was liquid.

GOOD ROUTE Pilots scope was mainly three-fold:

- To evaluate the system performance and assess its robustness across all use cases defined;
- To evaluate the system usefulness and user acceptance on behalf of all above types of users;
- To provide a preliminary insight on the expected impacts of the system in terms of safety, transport operation efficiency and inherent costs and finally comfort and QoL.

To address the above objectives, the following types of assessment were held in the context of the GOOD ROUTE Pilots, supported by the respective tools developed (all subjective forms developed are provided as Annexes of D7.2):

- **Technical validation of the system**, enabled through QoS questionnaires, developed to be completed by the Pilot supervisor in each case and logging mechanisms, developed for this purpose by the GOOD ROUTE developers. A logging mechanism was developed for each module, for the recording of the respective module performance during the Pilots. The data logged were exported in .txt files (by the respective developers) and sent for further processing. Logging mechanisms were developed for the OBU, the navigation client, the Control Centre, the DSS and the local node.

It was pre-agreed that all log files (coming from all modules, as aforementioned) should have the same reference in the common fields (i.e. Case ID, date, time, type of event, etc.). This was a necessary pre-requisite for the analysis to follow and, obviously, required the absolute synchronisation of all GOOD ROUTE module cooperating. The same reference was followed also in the event diaries mentioned below.

- **Human Factor assessment** (in terms of usability and user acceptance aspects) of the system, enabled through the following questionnaires developed:
 - Informed consent form
 - Entry form
 - User Acceptance and Usability Assessment questionnaire for drivers, operators, Police, emergency bodies, consignees and dispatchers (different for each actor)
- **Preliminary impact assessment**, enabled through the data logged, through the data recorded in the QoS questionnaires developed, through the info recorded in the event diaries developed and upon the analyses conducted and reported in D9.3: “CBA and CEA on developed applications”.

GOOD ROUTE was evaluated across the three aforementioned aspects following a common, more or less, pattern in all three sites, on the basis of the overall evaluation framework of D7.1. However, in addition, a full experimental plan was constructed, that went through several revisions, until it reached its final format.

The user group that was intended to test the GOOD ROUTE system functions consisted of 50 users in total (allocated as shown in the table below in the three sites). The user group consisted of all types of users involved in the GOOD ROUTE (envisaged) transportation chain, representing the Dangerous Goods drivers, infrastructure operators, consignees, local enforcement authorities and emergency bodies and the dispatchers.

Site	Month of execution	Co-Drivers	Operators	Consignees	Enforcement	Emergency	Dispatchers
Finland	December 2008	5	2	3	2	2	3
Italy	September 2008	5	2	2	3	3	2
Swiss	November 2008	5	2	3	2	2	2

Table 4: Participants per GOOD ROUTE pilot site.

Besides the above subjects, which were recruited from the User Forum of each country, persons from the technical workforce of the project participated (CRF, UPM/LST, PTV, CERTH) in all three Pilots, and in their whole duration, in order to assure the smooth execution of the trials and the prompt mitigation of any problems occurring.

The trials were executed with and without the DSS, which is the main element which served to distinguish the current (without GOOD ROUTE) situation and the envisaged future (with GOOD ROUTE) situation. In the “without GOOD ROUTE” case, the DSS was replaced by a conventional (and commercial) navigation system.

In all three pilot sites (Italy, Switzerland and Finland) the pilot tests procedures were structured in the same way (with minor necessary adaptations in each case).

All use cases defined for GOOD ROUTE have been evaluated through the Pilots in all three sites (the evaluation scenarios are described in D7.1, whereas they are decomposed in analytical tasks in D7.2). In each trial round, there was always a driver (always IVECO driver; legal restrictions were imposed for that on behalf of IVECO), and a co-driver (which was a real driver from the site and answered the relevant questionnaires). The Control Centre was always situated in the ADR office of each site, whereas the Local Node was installed in the entrance area of the tunnel or bridge (for Finland). All other actors participating, besides the driver and the co-driver, which were in the truck, were gathered in the ADR office, from where they attended and participated (with the assistance of the GOOD ROUTE team) to the evaluation scenarios. The GOOD ROUTE team assisted mainly with problems (if any) arisen during the evaluation regarding the system and also with the completion of the event diaries.

One full trial round encompassed in reality 4 routes. All 4 routes were held with the same co-driver in each case. Thus, each co-driver participating in the each site Pilots realised 4 routes (with always the same IVECO driver). Log files and event diaries were kept for

each of them. The drivers filled in the questionnaires (after the conduct of the trials) addressing the “driver”.

The first route started first with the Passport, continued with the environmental re-routing without the DSS, which was used as a reference point and closed with the enforcement and the emergency scenarios.

The second route started also with the Passport, then continued with the environmental re-routing but with the DSS and closed with the enforcement and the emergency scenarios.

The third route followed the same sequence but with the re-routing for refuelling with the DSS and the fourth the same but with the business related rerouting with the DSS.

Each full trial round, encompassing the four aforementioned described routes, was anticipated to last around 3-4 hours (variations in each site).

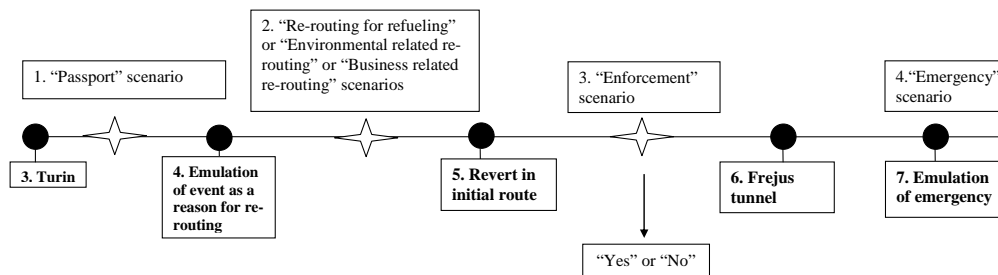

Figure 59: Example route followed in Pilots.

A pre-Pilot was held in the Italian site (Frejus tunnel) in July 2008. The tests were technical-oriented, thus no real users did participate; only the IVECO driver, whereas the role of the other participants (Police, Control Centre operator, etc.) was simulated by the GOOD ROUTE Partners.

During these tests, several technical problems, that were not identified before, were arisen. This was rather expected, as it was the first time the whole system was evaluated in a full route, encompassing all use cases. This rehearsal proved to be extremely useful for the finally smooth conduct of the final Pilots. The system robustness was strengthened and the efficient communication between the several modules of the system was verified. In specific, focus was given to the efficient operation of the system, when the logging mechanisms (necessary for the upcoming analysis) were added-on the modules.

The technical validation and human factor assessment results are provided in detail in D7.2: “Pilots results consolidation”. An insight to the expected impacts of the system in terms of safety and transport operation efficiency (utilising data and results also from the analyses conducted in the context of A9.4: “CBA and CEA”) is also reported therein.

The technical validation of the system revealed that the GOOD ROUTE system works as should, while the main problems detected were related to poor GPRS service level, affected in some cases by the weather conditions, and service roaming.

The use of the GOOD ROUTE system, did not affect the overall operation time, which means that GOOD ROUTE can be a system which at the same time increases safety, without creating time delays and other costs in the transport operation. The considerable safety impact of GOOD ROUTE is evident from the impact assessment held. It is also shown there that the combined minimum cost and risk route, which is the main concept of GOOD ROUTE provides many more benefits, not only in terms of safety, but also in terms of cost, length of route and travel time. The same is valid also in the case that equipped with GOOD ROUTE vehicles that would be allowed to pass special infrastructures (for which passage is restricted nowadays).

Emergency and enforcement, on the other hand, as shown from the technical validation results can be accomplished in a few minutes with GOOD ROUTE saving in this way lives and reducing delays and inherent costs (operational and safety related).

Finally, it is proved that it would be much more beneficial if GOOD ROUTE would be adopted from more than one infrastructures in each case, not only for safety reasons, but also in order to justify its investment.

It should be also highlighted that during the trials the information provided in each case, was the expected one, which indicated the good implementation of the system architecture and ontologies, whereas all users acceptance is highly rated.

The results coming from the Human Factors assessment make evident that according to all actors, GOOD ROUTE besides safety and transport operation efficiency enhancement, is envisaged to enhance the daily routines of all involved actors (drivers, operators, emergency/enforcement bodies, consignees, dispatchers), and despite the fact that in some case, some of them might find it complex, not intuitive enough, etc., the overall usefulness and satisfaction of the system is always positive for all types of actors. The lower rates are related to the increase of the time the GOOD ROUTE system adoption would require from the actors in their daily routines. Safety, reliability and cost-effectiveness aspects are always rated positively, whereas besides the operators, the GOOD ROUTE system is considered to enhance a lot the controllability of the transport operation. Finally, the main issue that actors seemed to be sceptical in their vast majority, is the potential of GOOD ROUTE to bring about new business opportunities; but, this, is in any case an objective that is quantitatively addressed in D9.3 CBA analysis and is not so much an objective of Human Factors assessment.

Finally, taken the above, it should be mentioned that the GOOD ROUTE system is still a prototype (a totally innovative one; not built upon pre-existing applications) and provided that, its performance and acceptance during the trials is considered according to initial expectations.

The Pilot execution was dealt in A7.2: "Pilot realisation" and the results consolidation was held in A7.3: "Pilot results consolidation". The overall evaluation framework and Pilots Plans for GOOD ROUTE trials are described in D7.1: "Final Pilot Plans", whereas the detailed experimental plan, the process followed for the execution and the analysis, the final tools used for the objective and subjective measurements and the results coming out of the Pilots together with the impact assessment are fully described in D7.2: "Pilot results consolidation".

1.1.4.8. WP8: Guidelines, Training and standards (COAT) [Start: M1-End: M36]

Objectives

- To detect all existing guidelines and standards regarding transportation of Dangerous Goods.
- To identify deficiencies and gaps of existing standards.
- To guarantee that all ethical and legal issues related to the project research are properly considered and any relevant conventions are respected.
- To develop training packages and GOOD ROUTE system best practices for DG transporters and traffic control operators.
- To propose new guidelines regarding application, maintenance, communication and training, addressing drivers, traffic control operators and technical workforce towards the introduction of new required standards.
- To guarantee the highest possible quality standards for all project deliverables.
- To ensure that the project proceeds properly and comes to an ethical and legal acceptable conclusion, achieving its aims and objectives, in accordance to its ethical code, schedule, and budget.

Activities

A8.1 Existing guidelines and standards (COAT)

A8.2 Training package for optimal application (CERTH/HIT)

A8.3 Proposal of new guidelines and towards required standards (ELPA)

A8.4 Ethical and legal issues (COAT)

Work performed and end results

A survey around existing standards and regulations related to DG transportation was performed in the context of A8.1: “Existing guidelines and standards.

All standards, guidelines and regulations collected by COAT with the assistance of ELPA, SIEMENS and TID, related to DG legislation and training, communication with other vehicles, security in Vehicular Communications, security design, identity management and safety inspection in tunnels have been summarised in D8.1: “GOOD ROUTE Ethics Manual”. D8.1 also reported in all ethical aspects that should be taken into consideration in GOOD ROUTE, concerning its implementation, Pilot testing and dissemination activities (A8.4: “Ethical and legal issues”).

The main ethical issues considered have been the protection of personal data of the several users involved in the project during the implementation and the Pilots phase, the way all project trials should be performed and the issues that should be taken into account for the DSS algorithms, in order to conform to security, privacy and confidentiality guidelines.

All national and international guidelines, relevant to the Dangerous Goods transportation and the ethical issues arisen for GOOD ROUTE have been collected and outlined.

Moreover, the specific regulations and legislation, valid in each Pilot site has been gathered.

The responsible body for the monitoring of conformity of the Project activities to the Ethics Manual was the Ethical Advisory Board of GOOD ROUTE established since the first year of the project, consisting of 3 members and an external expert and chaired by Dr. A. Bullinger. In addition, a Board responsible for the Pilots conduction, with regard to the conformity to all recommendation provided by this Ethics Manual, has been established.

According to the guidelines of this manual, the GOOD ROUTE Consortium and its Ethical Advisory Board were committed to perform no experiments with persons unable to give a valid consent, which is not foreseen anyway, since all subjects will be professionals (truck drivers, control centre operators, etc.) and to share no personal information about them without their permission. It was stressed that the personal data should be strictly protected and anonymised (as much as possible). No genetic information was collected. No user personal data and preferences were sent over the Network, nor were made available to any third party (i.e. for advertisement, marketing or even research – outside GOOD ROUTE objectives). Personal information will not be retained longer than 3 month after the end of the project.

Pilot subjects activities such as drinking alcohol, smoking, etc. were not an objective of this project, thus all ethical issues related to that were not applicable in this case.

All Pilots participants were requested to give their consent (although not necessary, since are professional drivers coming from the Consortium Partners) about participating in the Pilots and in any other activity of the project, after they have been respectively informed about the exact scope and the procedure to be followed. Finally, all algorithms that deal with decisions affecting third party and environment took into consideration the relevant ethical aspects.

The aforementioned overview of standards and regulations in the area constituted the basis for D8.3: “Towards Required Standards”. The work reported therein and held in the context of A8.3: “Proposal of new guidelines and towards required standards” resulted in overview of the most promising standards and policy actions related to dangerous goods transportation. GOOD ROUTE is correlated to them in two ways: either passively-in this case the way the GOOD ROUTE abides by them is described- or actively- in this case, the specific contribution of GOOD ROUTE to them is described.

As passive standards are viewed those related to eCall, enforcement schemes, Traffic Management Systems, and V2V/V2I communications (Chapter 4); whereas GOOD ROUTE provides active feedback to the European legislation related to Dangerous Goods transportation and to the creation of an ontological framework in this area.

In addition, 30 application guidelines have derived from the knowledge gained through the GOOD ROUTE development, integration, technical verification and evaluation phases. These guidelines are of concert of all parties that wish to use/adopt, maintain the GOOD ROUTE system. The guidelines are distinguished in technical guidelines, behavioural and legal/organizational guidelines. All of them are reported in the context of a specific template, in which it is indicated if they address the driver, the operator or the technical workforce (some of them are applicable for more than one type of users). In addition, it is indicated if they are existing guidelines, if they are verified throughout the project (actually through the technical verification or the Pilots of the project) or if

they are new guidelines (not verified; but recommended based upon the overall GOOD ROUTE Consortium gained know-how).

Finally, in the context of this WP, and in the context of A8.2: “Training package for optimal application”, the European legislative framework for training in the Dangerous Goods transportation segment (whenever existing) has been reviewed together with the existing national training schemes and tools in the area for drivers and infrastructure operators. A thorough literature review has been also conducted for the identification of the training needs. On the basis of the existing schemes and tools and the needs identified, a training curriculum for the drivers and the infrastructure operators has been formulated (see Annex 1 of this report), supported by a series of the training manuals specifically for the GOOD ROUTE sessions.

All training manuals provide guidelines for use, installation and maintenance (whenever applicable) of the respective module they address. The training manuals have been used also in the Pilots, prior to the trials execution for the various users’ acquaintance with the system.

The training curricula proposed by GOOD ROUTE are in compliance with relevant European regulation and national schemes, if existing, and, as such, are proposed as intermediate training sessions to existing training curricula. In this way, it is considered that their adoption on a common pan-European framework will be much more feasible. The training proposed by GOOD ROUTE for both drivers and operators includes both theoretical and on-the-job/practical sessions.

It should be noted that the proposed curricula and the intervention of GOOD ROUTE in them should be seen as a pattern for the introduction of training on eSafety systems and ITS in general in current training schemes. In the same way, GOOD ROUTE dedicated sessions have been embedded, training sessions for other innovative ITS systems may and should be embedded, given their wide penetration in the respective market segments. In this way, all types of users involved in the transportation chain will be enabled to keep up with the evolution and will be more susceptible in it, as soon as a basic framework has been set (meaning that it will be much easier for users already trained how to use a safety system to learn about more, emerging systems, when needed).

The training schemes proposed can be found in D8.2: “Training Schemes for DG Drivers and Traffic Control Operators”.

1.1.4.9. WP9: Dissemination and exploitation (ICCS) [Start: M1-End: M35]

Objectives

- Dissemination of the results of the project to all interested actors.
- Creation of a project User Forum, to guide the project research and adopt/spread its findings.
- Formulation of sound marketing and business plans for the exploitation of project results.
- Development of a viable scheme for constant project results application and update.

Activities

A9.1 Market status and needs (CERTH/HIT)

A9.2 Dissemination plans (ICCS)

A9.3 User Forum (ELPA)

A9.4 CBA and CEA (PTV)

A9.5 Exploitation and business plans (CERTH/HIT)

Work performed and end results

An extensive market survey with regard navigation and route guidance technologies, vehicle remote monitoring, tracking and diagnostics, on-board sensors, TMC existing solutions, fleet management operations, enforcement systems, communication technologies and risk analysis methodologies and algorithms in the transport sector and especially in the area of heavy and DG vehicles transportation has been performed in the context of A9.1: “Market status and needs”. Over 50 references addressing commercial and research solutions have been used for the compiled SoA, provided in D9.2: “Extended market report on GOOD ROUTE applications and preliminary exploitation strategy”. The technological, implementation and market barriers as well as the initial exploitation aspects and dissemination strategy were included in this Deliverable.

The competitive market framework identification led to the identification of three business cases of GOOD ROUTE, which constituted the basis for the CBA/CEA analysis performed in the context of A9.4: “CBA and CEA” and the final exploitation plans prepared in the context of A9.5: “Exploitation and business plans”. The full description of the Business Cases and their value chain are provided in section 1.1.6.3 and Chapter **Error! Reference source not found.** (Final Plan for using and disseminating the knowledge) of the current document.

Full CBA and CEA results are reported in D9.3: “CBA and CEA on developed applications”. Cost estimates of all components/entities involved in the GOOD ROUTE system have been collected from the Partners and iterated to make them consistent amongst each other and applicable to actual roll out. At the same time, quantitative data on DG traffic in the different test sites has been researched to allow to construct a quantitative scenario for DG vehicle fleet and passages in critical

infrastructures. Only few data exist here with sufficient detail, so a quantitative scenario was created based on information of the Frejus tunnel which makes assumptions on the missing information as plausible as possible.

The study reported in D9.3 consists of five parts:

- Description of the application and deployment scenarios for the GOOD ROUTE System as background to the CBA/CEA. Development of a quantitative scenario of DG fleets and passages through critical infrastructure installations for a five year period.
- Cost description of all GOOD ROUTE components with regards to investment, operation and maintenance.
- A Multicriteria analysis with 10 experts coming from ELPA to allow the evaluation of the system effects and impacts, not easily quantifiable in order to be addressed by the CBA analysis in the context of the GOOD ROUTE system. The Multicriteria analysis was performed through cross-comparison tables formulated specifically for this purpose. The templates used for the conduct of the analysis are provided in D9.3. A sensitivity analysis also followed.
- Cost benefit analysis including those cost and benefit items which are quantifiable. This excludes external/societal effects.
- GOOD ROUTE SWOT analysis.

The Multicriteria analysis was performed upon a series of evaluation criteria, considered applicable for the impact assessment of GOOD ROUTE. The ranking of each GOOD ROUTE deployment scenario on each of the criteria reflecting the expected impacts is shown in the following figure, whereas the overall ranking of the GOOD ROUTE deployment scenarios, incorporating the individual weight of the evaluation criteria (shown in Figure 61) is shown in Figure 62.

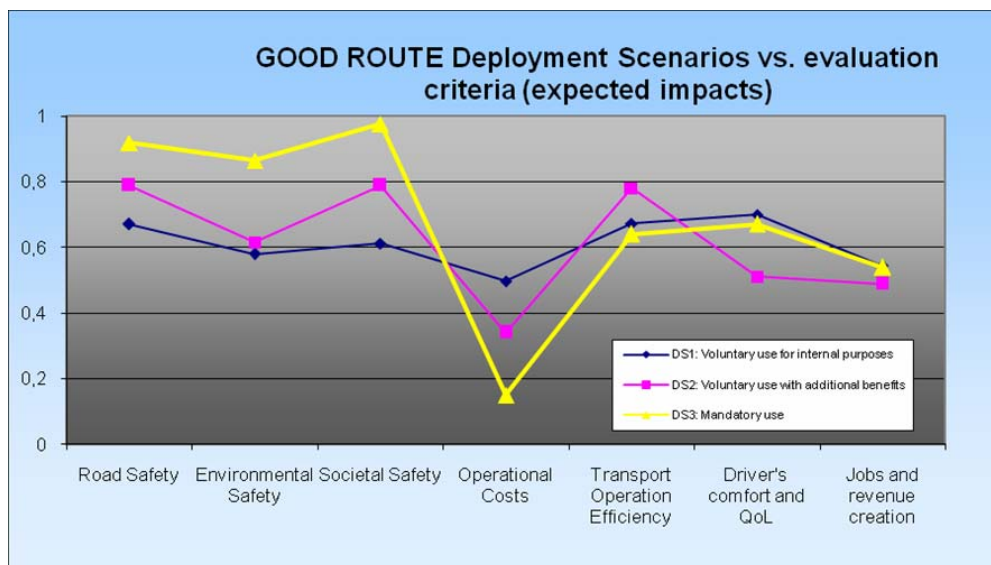

Figure 60: GOOD ROUTE deployment scenarios vs. evaluation criteria (expected impacts).

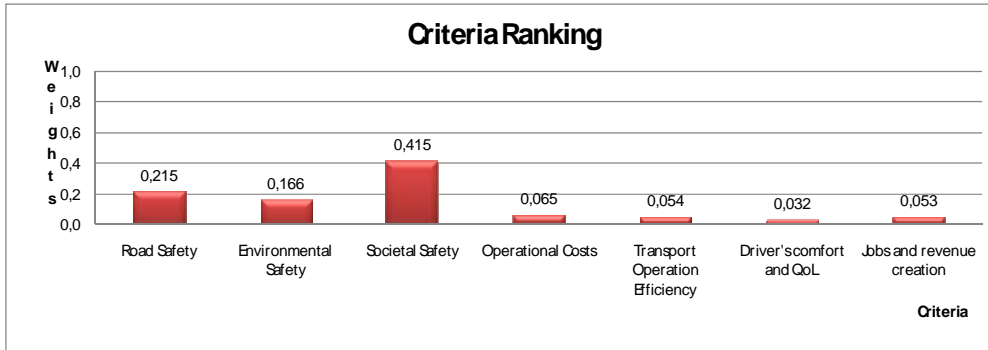

Figure 61: Ranking of GOOD ROUTE evaluation criteria (expected impacts).

According to the following figure, it seems that the mandatory use of the system seems to be the most desirable scenario in terms of expected impacts in comparison to the other two, whereas the voluntary use of the system for internal purposes for the company is the last one in the ranking, expected to bring about the less impacts.

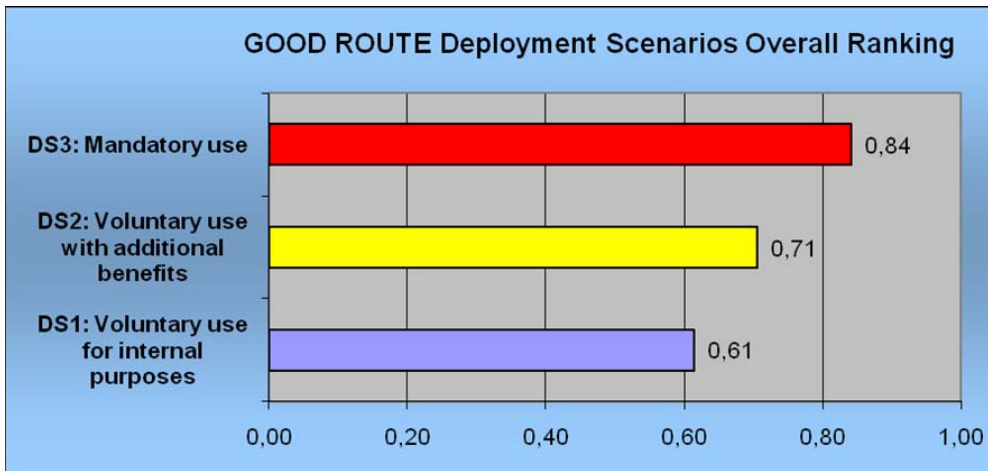

Figure 62: GOOD ROUTE deployment scenarios overall ranking.

As resulted from D9.3 studies, the major innovation and strength of GOOD ROUTE is the fact that GOOD ROUTE, in comparison to existing conventional fleet management systems, which are operating on the basis of the fastest or shortest route, calculates the minimum risk route (route with the minimum cost, with the maximum safety, combined route with minimum cost and maximum safety).

In addition to the estimation of the **minimum risk route**, the **minimum risk re-routing** is also enabled through GOOD ROUTE.

All conditions (business reasons, traffic jam or accident, weather conditions, other) are automatically identified by the system and the minimum risk re-routing is directly estimated, according to the rules set behind (depending upon the deployment scenario, it could be the company, the infrastructure operator or other entities that set these rules) and acknowledged to all actors of the logistic chain. This offers each user group a very **high process automation and guidance level in means of daily operations and decision finding**. Taking into account that GOOD ROUTE constitutes a win-win business proposition to all involved stakeholders, everyone involved benefits in terms of safety, comfort and even operational costs. There is also a noticeable potential for **added value services to which GOOD ROUTE can be extended with**, e.g. (security, overall environmental safety indices). This opens the opportunity to have a further improvement for the system and to keep it as state of the art for the next years. Besides investment costs, **especially the driver acceptance is being identified as critical parameter to the GOOD ROUTE SYSTEM**. In a possible roll out scenario, driver training can minimize acceptance discrepancies. As visualized in the following Sensitivity Analysis Matrix several positive cost-benefit ratios can be identified for a 3 site scenario.

		Time savings per passage and per vehicle [h]							
		0,8	0,9	1	1,1	1,2	1,3	1,4	1,5
No of passages per vehicle and year [N]	10	0,46	0,51	0,57	0,62	0,67	0,73	0,78	0,83
	11	0,51	0,56	0,62	0,68	0,74	0,80	0,86	0,92
	12	0,55	0,62	0,68	0,74	0,81	0,87	0,94	1,00
	13	0,60	0,67	0,74	0,81	0,88	0,95	1,01	1,08
	14	0,64	0,72	0,79	0,87	0,94	1,02	1,09	1,17
	15	0,69	0,77	0,85	0,93	1,01	1,09	1,17	1,25
	16	0,74	0,82	0,91	0,99	1,08	1,16	1,25	1,33
	17	0,78	0,87	0,96	1,05	1,15	1,24	1,33	1,42
	18	0,83	0,92	1,02	1,12	1,21	1,31	1,41	1,50
	19	0,87	0,98	1,08	1,18	1,28	1,38	1,48	1,58
	20	0,92	1,03	1,13	1,24	1,35	1,45	1,56	1,67

Table5: Sensitivity Analysis Matrix.

This implies also, that a **system implementation of the GOOD ROUTE system to less than 3 sites seems critical** justified in high investment costs for a basic setup and lower benefits due to a reduced area of effectiveness.

The SWOT analysis as well as the expected GOOD ROUTE impacts, based on the results of the CBA analysis and the Pilots results are provided also in the context of this report, in 1.1.5.

The first complete draft of the Exploitation Agreement was released, since the end of the 2nd year of the project (in the context of A9.5). The Exploitation Agreement has undergone constant revisions during the 3rd year of the project in order to get its final form and is under paper signing process by the GOOD ROUTE Partners legal departments. The exploitation agreement will be valid for 5 years after the official termination of the project. The final exploitation and business plans of GOOD ROUTE have been reported in D9.4: “Exploitation and Business Plans”, and are also reported in sections 1.1.6.3 and Chapter 2 of the current report. 6 GOOD ROUTE exploitable products have been identified.

-
- Minimum Risk Route Guidance System (D2.2, D2.1)
 - OBU (D3.2)
 - Control Centre and Logistic chain support modules (D4.2, D4.1)
 - Enforcement System (D5.2)
 - GOOD ROUTE vehicle platform (D6.3)
 - GOOD ROUTE integrated system and service (D6.2)

Dissemination activities in GOOD ROUTE have been held in the context of A9.2: “Dissemination Plans”. Their full description is provided in Chapter 2 (Final plan for using and disseminating the knowledge) of this document and a short overview in section 1.1.6. The following dissemination material has been produced in GOOD ROUTE:

- The GOOD ROUTE project logo.
- The GOOD ROUTE leaflet and the GOOD ROUTE poster, which have printed in glossy paper (2000 leaflets and 500 posters) and have been distributed by the GOOD ROUTE Co-ordinator to all Partners.
- The GOOD ROUTE web-site, which is uploaded to the URL: www.goodroute-eu.org.
- The Project Fact Sheet, which includes info for the project objectives and expected results, available also in German, French, Finnish, Italian, Spanish and Greek.
- 6 electronic Newsletters presenting the progress of the project since the first year of its life have been produced.
- A project video presenting the GOOD ROUTE objectives and results has been produced.

Throughout its whole duration, the GOOD ROUTE website was being updated in a regular basis with announcements on upcoming events, achievements, etc. relevant to the GOOD ROUTE project. The project’s results can be found on the relevant section of the website, while the users of the website are able to download the public Deliverables of the project from this section.

The GOOD ROUTE User Forum (dealt in the context of A9.3: “User Forum”), established from the first year of the project, was further enriched during the third year, in view of the final event and Pilots of GOOD ROUTE, consisting finally of around 100 members. The User Forum members were invited to all dissemination events organised by GOOD ROUTE, were sent the project Deliverables, whilst participants of the Pilots were recruited from them.

During the first year of GOOD ROUTE, a Greek language workshop and a Pan-European workshop were held on 13.04.06 and 08.09.06 respectively for the communication of the project objectives and the identification of the relevant actors’ user needs and the project Use Cases. GOOD ROUTE also participated in three EC

concertation meetings, namely “ICT for Transport” (two of them) and “ICT for safety mobility”.

In addition, during the 2nd Year of its lifetime, GOOD ROUTE participated in the second meeting of the “ENT12 Tracking and Tracing of Dangerous Goods”, presenting the activities of the project and establishing links with the Action Groups members.

The joint GOOD ROUTE and EURIDICE International workshop, with the support of SMARTFREIGHT and ROADIDEA European Projects, entitled “ICT in Transport Logistics” has taken place during the 3rd Year of the project). The workshop was held at Lucerne, Switzerland, from Monday the 3rd of November to Wednesday the 5th of November 2008, attracting around 70 participants. The first day of the joint workshop was devoted to the demonstration of the GOOD ROUTE system and the GOOD ROUTE vehicle demonstrator, whereas a visit to the Gotthard tunnel took place, so as to allow the demonstration of the project use cases. The second day was devoted to joint GOOD ROUTE and EURIDICE workshop sessions and key note sessions. The third day of the workshop has been devoted to the EURIDICE business forum kick off meeting. The workshop was successfully closed with a networking cocktail and guided tour in the Transport Museum of Lucerne. The minutes of the workshop have been synthesised by EURIDICE project, incorporating GOOD ROUTE contribution. The workshop has been strongly disseminated via the project web site, since the agenda and on-line registration was provided through it.

The project logo, leaflet, posters and web site have been produced, disseminated and submitted to the EC within the framework of D9.1: “Project logo, www site, leaflets, posters”. The dissemination strategy goals, the dissemination manager tasks, the target groups and the User Forum activities, the dissemination channels and roadmap and the principles according to which, all dissemination activities have been performed within the project, have been defined in the context of D9.2: “Extended market report on GOOD ROUTE applications and preliminary exploitation strategy”. GOOD ROUTE has attended a series of events and produced a series of publications during the 3 years of its lifetime. The full list of the dissemination activities of GOOD ROUTE is provided in Table 10 of this document.

1.1.4.10. WP10: Project management (CERTH/ITI) [Start: M1-End: M36]

Objectives

- To effectively monitor the project, in administrative, technical and financial terms.
- To guarantee the adherence of the work to the overall project plans, available resources and timing.
- To assure the high quality of the project outcomes.
- To offer the necessary interface to the EU services and external actors.

Activities

A10.1 Administrative Management (CERTH/ITI)

A10.2 Technical Management (CERTH/HIT)

A10.3 Quality Assurance (CERTH/HIT)

A10.4 Scheduling, communication and reporting tools (ICCS)

Work performed and end results

The management responsibilities were shared between CERTH/ITI (as the project Coordinator) and CERTH/HIT (as the project Technical Manager). During the project duration 10 plenary meetings, several technical and integration meetings and 3 annual reviews were held. The project management team was responsible for their full organisation. It was also responsible for the overall monitoring and organisation of the dissemination workshops (Greek national, Pan-European, International) held in its 3 Years of life and the attendance of the concertation meetings in the area.

All required according to the Contract administrative documents (Quarterly Management Reports, Annual Activity and Management Reports, Accompanying questionnaires for the 1st and the 3rd year of the project) together with all Deliverables produced within the 3 years were submitted to the EC as required. A quality procedure was defined from the early beginning of the project, in order to assure the quality of the Deliverables produced. Thus, all Deliverables submitted to the EC, have been peer reviewed according to the defined scheme

All project activities have been closely monitored on a daily basis from the user needs phase to the integration and evaluation phase, where the scheduling tools developed in the project have been maintained in order to facilitate daily communication.

1.1.5. Impact on Industry and Research Sectors

1.1.5.1. General view

The GOOD ROUTE Consortium has throughout the project continuously monitored the developments in the area, not only in Europe but also worldwide, with a special emphasis on the US Market. GOOD ROUTE aimed to involve all key actors in the dangerous goods transportation chain, as well as OEMs and sensor suppliers, in order to result to an optimal business strategy for wide and quick diffusion of the GOOD ROUTE system.

GOOD ROUTE may be successfully diffused only if key actors in the development and operation chain are actively involved in its realization and convinced upon its value. Thus, representatives of all of them were included in the established project User Forum from the early beginning of the project. The User Forum was further enriched during the third year of the project, pending the final event and the Pilots of GOOD ROUTE. The project User Forum consists of safety advisors/trainers, DG drivers and drivers associations representatives, road and special infrastructure operators (tunnel, bridge, etc.), OEMs, ADAS/IVICS, sensors and communication device developers, middleware, digital maps and service providers, road safety authorities, municipalities and other local actors and citizens' representatives, such as automobile clubs and journalists, coming from all over Europe, and also non-European countries.

The User Forum has raised awareness upon current problems in Dangerous Goods supply (i.e. Dangerous Goods vehicles not allowed to cross main highway tunnels but going through secondary roads, that may lead them to densely populated areas instead). Thus, the GOOD ROUTE solution necessity and importance has been highlighted and promoted.

In addition to the establishment of a representative User Forum, a series of dissemination activities have been realized throughout the duration of the project. The dissemination material (leaflet, logo, poster, web site, fact sheet, project video, etc.) produced since the first year of the project served as the basic means of the diffusion of the project objectives and results in workshops, conferences and concertation meetings. In addition, the GOOD ROUTE Consortium realised a series of publications in conferences and/or scientific journals during the GOOD ROUTE project life, following the concise publication strategy defined within the project (see Annex A for the overview of the publications). After the first Pan-European workshop, the joint GOOD ROUTE and EURIDICE International workshop, with the support of SMARTFREIGHT and ROADIDEA European Projects, entitled "ICT in Transport Logistics", has taken place during the third year of the project. The workshop was held at Lucerne, Switzerland, from Monday the 3rd of November to Wednesday the 5th of November 2008, attracting around 70 participants.

Apart from the enhancement of public awareness and acceptance with regard to safe and secure transportation of dangerous goods via its dissemination activities, GOOD ROUTE is expected to have major strategic impact in the area of Dangerous Goods transport, through:

-
- Meeting social demand for acceptable risk levels and safety maximization in the transportation of dangerous goods.
 - The creation of a decision support and routing procedure commonly concerted by the very large and very small enterprises, taking into account equity schemes.
 - The provision of real time and dynamic data to the dangerous goods logistic chain, thus maximizing the efficiency of transportation and reducing its cost.
 - The establishment of a low-cost and high-reliability monitoring and enforcement system for dangerous goods vehicles.
 - The establishment of pan-European cooperation in monitoring and controlling dangerous goods movements.
 - The reduction of congestion and other problems due to dangerous good vehicles by controlling their numbers and types at any given part of the network at any moment.
 - The creation a standardized ontological framework for dangerous goods classification, monitoring and control, that optimizes the use of the network by such goods carrying vehicles, while always, protecting public safety.
 - The application guidelines and training schemes developed in its context that will rationalize and optimize dangerous goods transportation.

GOOD ROUTE's impact is expected to be significant, given that the problem of Dangerous Good's safe transportation is not a local one, but one that goes beyond national boundaries and requires pan-European actions, since:

- Only through pan-European common ontologies can the movement and cargo of such vehicles be monitored and enforced.
- OEMs and sensor/telecom suppliers may provide viably the necessary solutions only within the range of the European Market.
- As the PRESTIGE accident has shown, such catastrophes may happen at any moment, anywhere in Europe and pro-active action is required to guarantee citizens' safety and security throughout Europe.

Finally, the close collaboration of OEMs, sensor/telecom providers and operators, Dangerous Goods companies, infrastructure operators and other key stakeholders from 6 EC countries, ranging from North (Finland), to Central (Germany, Switzerland) and South (Spain, Italy, Greece) guaranteed the pan-European dimension of the project.

The intentions of the GOOD ROUTE Consortium for further exploitation of the project results are reflected in the Exploitation Agreement, which is under paper signing process, which constituted the basis for the Exploitation and Business Plans reported in D9.4: "Exploitation and Business Plans" (summarised in Chapter 2 of the current report).

1.1.5.2. *Insight in GOOD ROUTE expected impacts*

After the conduct of the Pilots, a short but revealing impact assessment was performed in the project, summarised in D7.2: “Pilot results consolidation”. It is also provided here, as it is considered to provide a valuable insight in the GOOD ROUTE expected impacts.

Safety impacts

Since it was not possible to objectively assess the GOOD ROUTE system through the Pilot trials (obviously no accidents and injuries could be provoked), an indicative safety impact assessment has been performed on theoretical level, with the assistance of the DSS simulator and the risk assessment methodology behind.

The scenario is dealing with a BLEVE explosion occurring in a DG transport operation. The percentage (%) of fatalities, injuries as well as range of them around the spot of the accident have been used as entry points for the analysis.

In our case study, there are two route alternatives (for the same origin and destination): a short one through an urban centre and a longer one through inhabited suburb.

For safety risk assessment, the safety related consequences of accidents are quantified first of all in terms of provoked fatalities and then in terms of 1st and 2nd degree injuries.

For the definition of the above numbers, it is necessary to know the overall population which is exposed to the accident consequences.

The definition of the number of exposed persons is related to the population density and the area exposed and the percentage (%) of the population that is present at the time of the accident in the respective area, as well as the specific percentage (%) of persons outdoor and on road (which are directly exposed to the accident consequences).

In this analysis, we have assumed that the urban centre daytime population density is equal to 0,05 persons/m², while the population density in the sub-urban area is 0,012 persons/m².

As seen in the following table, roughly 80% of the population of the suburban district will remain in the area during the whole night, whereas, during the day, the % of the population present in the area ranges from 30% to 70% (average: 50%), due to mobility reasons (i.e. transportation to jobs, etc.). Downtown on the other hand, roughly 50% of the population is present during daytime (working, as opposed to 10% during night time; residents).

	Suburb		Downtown (city centre)	
	Day	Night	Day	Night
	08.00-18.00	18.00-08.00	08.00-18.00	18.00-08.00
Population present	50%	80%	50%	10%
Population outdoor	7%	1%	7%	1%
Population road	congestion (both directions)	20 (que in meters)	congestion (both directions)	20 (que in meters)

Table 6: % of population present, outdoor and in road during day and night in an inhabited area.

The percentage of the Population is classified according to the following classification of a 24-hours day:

- Day: 08.00am – 18.00pm
- Night: 18.00pm – 08.00am

It should be noted that the aforementioned data of population density and allocation are quite generic and vary a lot, depending on the area, the season, the weather conditions, the day of the week, the level of development of an area age range of the area, the time of the day, the socioeconomic status of the area, etc. In a full analysis, all the above characteristics need also to be quantified and incorporated in the analysis.

According to the estimations made (the full analysis is available upon request), the following results have emerged, presented in the table below. The fatalities, 1st and 2nd degree injuries in the 4 scenarios (day-urban; day-suburbs; night-urban; night-suburbs) are presented in the following table.

Fatalities not included in injuries and 2nd degree not included in 1st degree				
	Day-Nurban	Day-Suburb	Night-Nurban	Night-Suburb
fatalities	58	10	5	15
2nd degree	14	1	1	4
1st degree	123	9	10	33

Table 7: Fatalities and injuries in an inhabited urban and suburb area during day and night.

As it is obvious, according to these estimations (which constitute the outcome of the minimum safety risk assessment methodology), the minimum safety risk route emerging from GOOD ROUTE would be in the day to go through the suburb and in the night through the city centre and would result in:

- 82,8% reduction in fatalities (if the route was performed during the day);
- 92,3% reduction in 2nd degree injuries (if the route was performed during the day);
- 92,7% reduction in 1st degree injuries (if the route was performed during the day);
- 66,66% reduction in fatalities (if the route was performed during the night);
- 75% in 2nd degree injuries (if the route was performed during the night).
- 70% in 1st degree injuries (if the route was performed during the night).

It is evident from the above that the safety impact of GOOD ROUTE can be enormous.

In addition to the above theoretical analysis, the technical validation of GOOD ROUTE in the Pilots made evident that, besides, the positive safety impacts coming from the routing/re-routing functionalities of GOOD ROUTE, the emergency functionality should be also not neglected. As test results shown, emergency (with notification of all the corresponding actors through the portal) is accomplished within 1,8min. (mean value of the respective test results), which means that in hardly 2 minutes, all emergency actors are notified of any accident/incident happening-the safety impacts are self-evident.

Impacts on Transport Operation Efficiency and inherent costs

In the analysis presented in D9.3: “CBA and CEA on developed applications”, there were three alternative routes compared in terms of distance, travel time, cost and risk, namely the minimum cost route, the minimum risk route and the combined route minimising at the same time cost and risk.

In the table below, we can see the **total distance, travel time, economic cost and risk** for each of the three routes, as well as the difference of those values when compared with the corresponding values of the first route (minimum economic cost route).

	Minimum Cost	Minimum Risk	Difference	Minimum Combined Cost	Difference
Distance	53,841	96,449	79,14%	57,076	6,01%
Travel Time	1:46:59	2:17:29	28,51%	1:52:32	5,19%
Cost	36,211717	58,629746	61,91%	37,952114	4,81%
Risk	49,023407	10,061643	-79,48%	15,857708	-67,65%

Table 8: Total distance, travel time, economic cost and risk for three alternative routes.

In the case of the minimum risk route, the overall distance and the total economic cost are greatly increased (79,14% and 61,91%), while the total risk is almost equally decreased (79,48%). The travel time is also increased (28,51%) but not so much as the

aforementioned values. Thus, the minimum risk route achieves the minimisation of the risk with the price of an equally big increment of the cost.

In the case of the minimum combined cost route, however, we experience a similarly big reduction of the total risk (67,65) with only a slight increment of the overall distance (6,01%), travel time (5,19%) and economic cost (4,81).

Therefore, we conclude that the combined route, which minimises cost and risk at in the best possible way in each case and which is the one GOOD ROUTE system has been based is the optimal one, when we take into account the overall risk, as well as the business needs. It is also easier to be adopted by the interested parties than the more costly minimum risk route.

In D9.3, another analysis was also conducted, in order to assess the impacts when a DGV is not allowed to pass through a restricted tunnel, while those restrictions wouldn't apply to a similar DGV that makes use of the GOOD ROUTE system (passport functionality of GOOD ROUTE).

Nowadays, most DGVs are not allowed to pass through sensitive parts of the infrastructure, such as tunnels and bridges. In those cases, they are forced to follow big deviations, greatly increasing the cost of route, pollution and maybe even the overall risk. GOOD ROUTE adoption will allow the passage of equipped vehicles through special infrastructures. These two cases have been compared in terms of the total distance, travel time, economic cost and risk of each of the two alternative routes.

In the table below, we can see the total distance, travel time, economic cost and risk of each of the two routes, as well as the difference of those values when compared with the corresponding values of the first route (minimum combined cost route of the equipped DGV).

	Equipped DGV	Non-equipped DGV	Difference
Distance	44,282	56,938	28,58%
Travel Time	0:50:58	1:24:29	65,76%
Cost	26,397811	37,127104	40,64%
Risk	0,215229	0,623061	189,49%

Table 9: Total distance, travel time, economic cost and risk for equipped and non-equipped DGV (allowed/not allowed to pass through the infrastructure).

It is obvious that the deviation which the non-equipped DGV is forced to follow has a very negative impact to all the observed values. The distance increases by 28,58%, the travel time by 65,76%, the total economic cost by 40,64% and the total risk by 189,49%.

From the above, we conclude that the use of the GOOD ROUTE system cannot only reduce the overall risk, but the total economic cost as well, when sensitive parts of the infrastructure are concerned.

Finally, according to D9.3, on one hand, the system itself takes a minimum investment of 2.66 Mio. € in case of 1 year operation and 1 site. Within a time horizon of 5 years, the system costs reach a total of +27 Mio. € in case of 1 site. The main reason for this economic situation is massive investment and operation cost in the OBUs of the DG vehicle fleet, which therefore can hardly be justified for a single infrastructure object.

Thus, although even one site can be theoretically being operated with overall benefits under certain assumptions, nevertheless, it is recommended, for both economic and safety reasons, that the system is being introduced for all/most critical infrastructures in a region (at least 2 sites).

Finally, as made evident from the analysis of the technical validation in the GOOD ROUTE Pilots, the system does not create any additional delays in the transport pre-trip and on-trip phases. The operation time between the Control Centre and the DSS, which encompasses both the communication time and the processing time of the DSS and the Control Centre is negligible, while the DSS does not also seem to affect at all the overall time required for the accomplishment of the routing/re-routing scenarios (in comparison to the existing route guidance systems), although one should take into consideration the fact that the DSS is still a prototype, which by default does not incorporate all those, frequently “heavy” features, that a commercial product does.

As also shown from the Pilots, efficient enforcement is also enabled through GOOD ROUTE. Nowadays, several dangerous goods vehicles pass through a toll station of a highway, soon after which a long bridge or tunnel starts. The vehicles either pass through the bridge/tunnel or are sent by a RO-RO ferry to the other side, losing far too much time. If the police decides to make checks it needs to stop all heavy trucks, to check their speed (through the speedometer on-board) and pass them through a specific infrastructure to measure the load per axle. It should also check the type of load carried, etc. **The overall check time per vehicle is from 10-30 minutes**, while the expected rate of rules violation is roughly 7-10%. GOOD ROUTE technical validation results showed that for the accomplishment of the enforcement in GOOD ROUTE (where both the driver and the respective enforcement units are notified) **is accomplished in less than 1,5 minute** (mean value according to the test results) automatically (for all vehicles in the area). This reveals the great economic, traffic efficiency but also safety impact GOOD ROUTE enforcement could bring about. Time delays related to enforcement are minimised, automation inevitably prevents from unnoticed violations, which could result in great safety risks (depending the violation), whereas the enforcement personnel effort is minimised.

Impacts on comfort and QoL

Besides the aforementioned estimated impacts, one should not neglect the impact the system would have in terms of driver comfort and general QoL. The results coming from the Human Factors assessment make evident that according to all actors, GOOD ROUTE, besides safety and transport operation efficiency enhancement, is envisaged to enhance the daily routines of all involved actors (drivers, operators,

emergency/enforcement bodies, consignees, dispatchers), and despite the fact that in some case, some of them might find it complex, not intuitive enough, etc., the overall usefulness and satisfaction of the system is always positive for all types of actors. As can be seen through the following figure, the lower rates are related to the increase of the time the GOOD ROUTE system adoption would require from the actors in their daily routines. Safety, reliability and cost-effectiveness aspects are always rated positively, whereas besides the operators, the GOOD ROUTE system is considered to enhance a lot the controllability of the transport operation. Finally, the main issue that actors seemed to be sceptical in their vast majority, is the potential of GOOD ROUTE to bring about new business opportunities; but, this, is in any case an objective that is quantitatively addressed in D9.3 CBA analysis and is not so much an objective of Human Factors assessment.

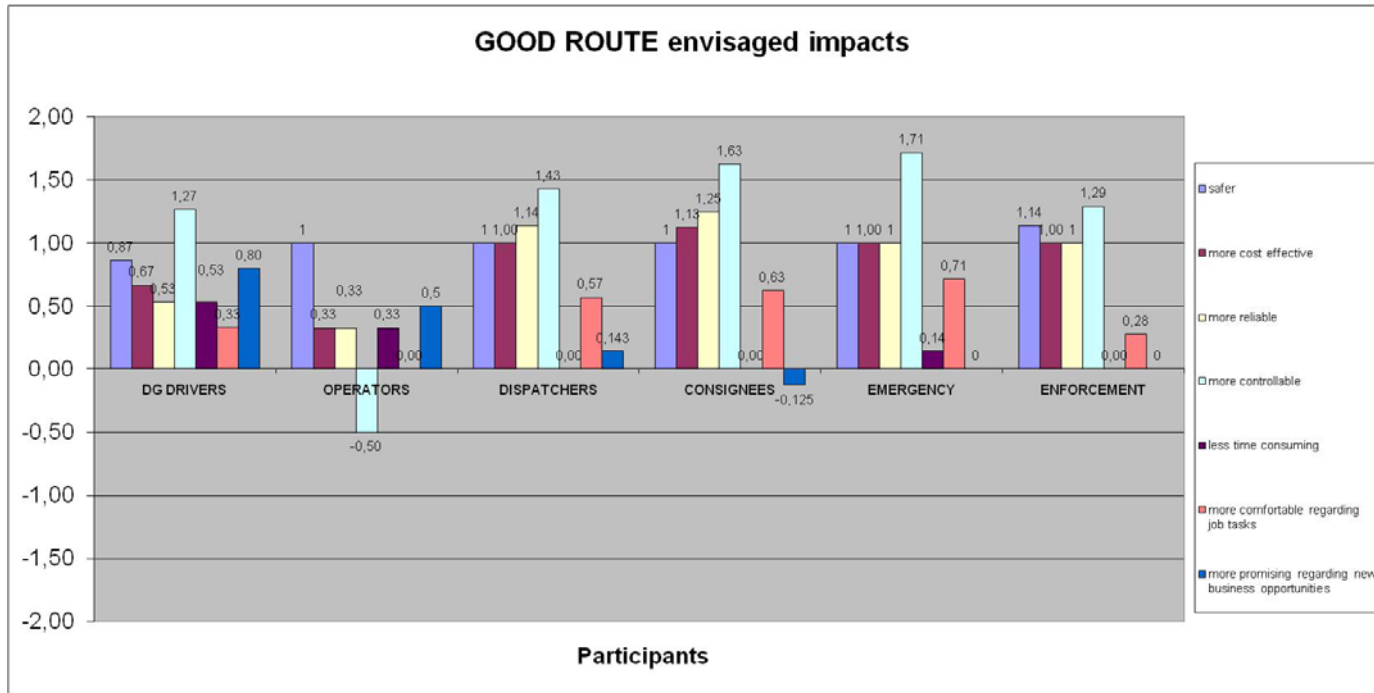

Figure 63: Overview of GOOD ROUTE envisaged impacts according to Pilot participants interviewed.

1.1.5.3. *GOOD ROUTE SWOT Analysis*

The SWOT analysis performed in GOOD ROUTE, in the context of D9.3: “CBA and CEA on developed applications” is also provided below.

Strengths

- **Minimum Risk Route Guidance**

The major innovation and strength of GOOD ROUTE is the fact that calculates the minimum risk route (route with the minimum cost, with the maximum safety, combined route with minimum cost and maximum safety) and that, in comparison to existing conventional fleet management systems, which are operating on the basis of the fastest or shortest route. In this way, it is the first time that a system, placed actually in the fleet management segment, does take into consideration the safety aspects of the drivers all road users, as well of the 3rd party population.

- **Automatic Minimum Risk Re-routing**

In addition to the estimation of the minimum risk route, the minimum risk re-routing is also enabled through GOOD ROUTE. All conditions (business reasons, traffic jam or accident, weather conditions, other) are automatically identified by the system and the minimum risk re-routing is directly estimated, according to the rules set behind (depending upon the deployment scenario, it could be the company, the infrastructure operator or other entities that set these rules) and acknowledged to all actors of the logistic chain. All the decision and execution burden related to the change of route is taken off the driver, who is assisted with an easy to use navigation system, easily installed in his/her vehicle.

- **Passport for infrastructure passage**

The “passport” for passage function, through several infrastructures, is another major strength of GOOD ROUTE. Time delays, related also to additional costs for the company and the infrastructure, are being averted in this way, whereas the infrastructure achieves to have an overview of its traffic network and manage the transport operation much more efficiently. The same is valid also for the company, that is enabled to plan the itineraries of the vehicles in advance and estimate a very close to reality time of arrival to destinations, which enhances the flow of the overall logistic chain. Finally, the driver is very much enhanced in his/her daily employment tasks, since s/he knows in advance the schedule of the day and may plan his/her trip in the most convenient for him/her way.

- **Enforcement/emergency**

Automatic enforcement and emergency support are also considered as strengths of the system. Automatic enforcement comes to replace conventional escorting held in infrastructures nowadays, and to achieve higher level of compliance to the valid in each case regulations. The operators of the infrastructure know in advance what is transferred in their site, which also enables them to allow the passage of more vehicles through it, since they will be assured that it is safe and since they will be prepared on how to mitigate potential risks (enforcement functionality). This will enhance also the transport operation as a whole, since unnecessary deviations, leading to longer and thus more costly trips, will be averted, which is beneficial for both the companies and the drivers. Finally, this comes to be also beneficial for the society as a whole, since routes through densely population areas will be avoided. The emergency functionality in specific will allow prompt detection of malfunctions and failures of any type and

respective reaction by the corresponding entities. In this way, loss of human lives and large scale damages to the infrastructure are prevented.

- **GOOD ROUTE Control Centre: an info point for the whole logistic chain**

The feasibility of all the above use cases, which require the involvement of all parties related to the transport operation, is achieved through the GOOD ROUTE Control Centre. All actors with different accreditation rights are enabled to monitor the transport operation of the equipped fleets and any changes occurring to that through a portal, which notifies them on the interesting and significant for them events in real-time. Thus, depending on the emerging situation, quick decisions are made from the side of the infrastructure operators and the companies and prompt reaction is enabled from the respective entities in case of problems (reasons for enforcement or emergency). In this way, even customers benefit directly, since they are also authorised to monitor the operation status of their own goods.

- **Driver always in the loop**

The driver, from his/her side, is also enabled in his/her daily tasks, through the navigation client, via which s/he is notified automatically for any changes in his/her route, as well as through the in-vehicle display, through which s/he is notified for any violations made (regarding his/her vehicle and its cargo). The on-board unit also enables the communication in emergency cases. In this way, the driver is always kept in the loop.

- **Instantiation of GOOD ROUTE Decision Making according to local rules and stakeholders weighting factors**

The local rules imposed by each infrastructure in normal flow constitute the framework, upon which the GOOD ROUTE Decision Support System operates and provides the minimum risk route. A great flexibility of the system is the fact that any change in the local rules or addition of new ones, corresponding to new infrastructures subscribed, is easily followed by change of the framework set behind the decision process of the system. In a similar manner, the weights imposed to each contributing factor for the estimation of the combined minimum risk route (minimum cost and maximum safety for drivers and third parties) can be also modified, depending upon the priorities in each case. Thus, a different weighting system may be applied, following the deployment context of the system (local, national, European context), the main actor behind the system (dispatcher, infrastructure, contractor, public entity), the governmental priorities each time, etc.

- **Common Ontological Framework**

The basis for the communication principles in GOOD ROUTE has been set in the ontological framework, developed from its early beginning. The ontological framework is developed in such a way, so as to include, if needed, more attributes corresponding to more parameters (related to vehicle, cargo, transport operation as a whole) as well as to more context of use, beyond road transport. It is open to be interfaced by other ontologies, enabling the connection of GOOD ROUTE to existing systems. It is the main asset of GOOD ROUTE that will allow its wide scale adoption and its compliance to the existing systems, raising in this way its penetration potential and viability.

- **Compliance with emerging technologies**

As evident through D8.3: “Towards required standards”, GOOD ROUTE complies with all relevant to it standards, which strengthens its penetration potential. It is well placed in the context of the European Directives for Dangerous Goods transportation; it complies with C2C, I2C, C2I and TMC standards, security standards, etc.

- **Benefits for all**

GOOD ROUTE constitutes win-win business proposition to all involved stakeholders. The company, the drivers, the infrastructure, the customers, the enforcement and the emergency units and, above all, the whole society, benefit in terms of safety, comfort and even operational costs.

- **Vast potential for added value services**

GOOD ROUTE context may be easily extended in many aspects. The decision making may anticipate more dimensions than the ones already considered (i.e. security, overall environmental safety indices), the telematic system could include more functionalities (like driver monitoring systems and other Advanced Driver Assistance Systems), more actors, if applicable, could be involved and access the Control Centre, whereas the context of use could be enlarged, including other transportation segments, besides the Dangerous Goods transportation, as well as other transportation modes, besides road transport. The cooperative principles embedded in the system architecture would allow more advanced communication potentials, which have not been demonstrated in the context of GOOD ROUTE, like communication with other vehicles or other infrastructure items (VMS, beacons, V2V, etc.).

Weaknesses

- **Need for instantiation/update of map data**

The map data utilised by the Decision Support System of GOOD ROUTE need to be constantly updated, whereas each time a new infrastructure is subscribed to the GOOD ROUTE service, the population and safety related map data of the region needs to be constructed and added in the back-end.

- **Missing real time accident and updated population data**

The GOOD ROUTE Decision Support System, among other data, utilises accident and population data in order to calculate its indices. In case such data are missing, historic data need to be utilized instead, which are, however, not always representative of the recent reality.

- **Need for medium to large scale deployment of the system**

As it is evident from the above CBA analysis results, the more infrastructures do subscribe in the system the more beneficial the system proves to be for the Logistic Company. Else, the systems, at least from monetary aspects, does not pay off the investment required on behalf of the company, which may constitute a barrier for its initial penetration in the market.

- **Need for scope widening**

The Minimum Risk Route Guidance of GOOD ROUTE takes currently into account the minimum risk route in terms of costs and safety (on individual and on combined basis). Although, in this way, it already addresses a great share of risks related to transport operations, aspects like security, overall environmental protection, etc. are factors that are not at the moment anticipated in the decision making process and comprise a recommendation for further enrichment of the system. A further enrichment would be also related to the application of the service in a wider segment of the transport operations, dealing with the transportation of other types of goods (i.e. high value goods) or even public transport. In this way, the target market for GOOD ROUTE would be enlarged significantly.

Opportunities

- **High societal and business risk**

In the last 10 years more than 200 people have died in Europe's tunnels and the direct cost of these accidents were about 210 million Euros per year. Meanwhile, 0,5% of total accidents occur in bridges, 3% of which are fatal ones. And the number of such critical infrastructures (i.e. urban tunnels, highway tunnels, long bridges, etc.) is expected to increase by 35% until 2010. The societal and business risk is evident and constitutes the main rationale for research and deployment of GOOD ROUTE like systems.

- **ERA-NET Transport Action Group, ITS Action Plan, UNECE, relevant Directives and initiatives relevant to GOOD ROUTE**

There is a series of Directives and Action Plans that constitute the appropriate regulatory framework for GOOD ROUTE, to fit in and comply with. The most outstanding and relevant to GOOD ROUTE, which prove that the project has been in line with the European and international trends and priorities in the area, are outlined below.

The ERA-NET TRANSPORT Action Groups are aiming at coordinating national research policies in the field of transport. Sixteen partners (mainly ministries) from thirteen countries are working together towards this coordination. The final objective is to create a strong and unified European Research Area in the field of transport. Therefore, various European countries are searching the ways and means to launch a common research project to find out what would be the requirements for a European system, which would make interoperable different local, national and regional systems.

In specific, the Action Group 12 (ENT12) is trying to coordinate national policies of research in the specific field of the transport of dangerous goods. In addition, within the framework of this Activity, an inventory of the norms used by different actors for the collection and exchange of data are drawn. Relevant norms identified include: ISO 17687 concerning "Transport Information and Control Systems (TICS); General Fleet Management and Commercial Freight Operations; Data Dictionary and Message sets for electronic identification; Monitoring of Hazardous Materials/Dangerous goods transportation; and DATEX2. The final list of standards will be composed within this activity.

Furthermore, the ITS Action Plan, entitled "An Action Plan for the Deployment of Intelligent Road Transport Systems for More Efficient, Safer and Cleaner Transport" is meant to identify the contribution which ITS can make for improving road transport efficiency, safety and security, and for reducing the negative impacts of transport on the environment and is in line with GOOD ROUTE priorities.

Finally, the recently emerged Directive 2004/54/EC, on minimum safety requirements for tunnels in the trans-European road network creates a comprehensive regulatory framework addressing both administrative practices and infrastructure and technical standards. 512 tunnels will be affected in the European Union, mostly in Austria and Italy.

In addition, the United Nations Economic Commission for Europe (UNECE), the major international forum regarding tunnel safety should be mentioned. 55 international agreements and conventions have been elaborated (ADR signed in Geneva in 1957, UN Convention on Road Traffic-Geneva 1949, ...).

Another initiative has emerged by the UNECE Working Party on Road Traffic Safety in 1999 (a group of experts developed “recommendations for minimum requirements concerning safety in tunnels of various types and lengths”). In addition, an Ad-hoc Interdisciplinary Group of Experts on Safety in Tunnels under the aegis of UNECE Inland Transport Committee (2000) has been established. In December 2001, the UNECE group presented 43 recommendations concerning road users, tunnel operation, infrastructure and vehicles.

Finally, the study by the OECD and PIARC (World Road Association) produced in 2001 on the transport of dangerous goods through road tunnels, is actually picturing GOOD ROUTE. It is reviewing past tunnel accidents and national legislations, and proposing three tools for a better management of risks: harmonised groupings of dangerous good loadings, a risk quantification model, and a decision support model.

Thus, GOOD ROUTE provides the answer and an enabling platform to many different policy initiatives and legislative actions.

Threats

- **Dangerous Goods Vehicles Drivers Acceptance**

It is common knowledge that the drivers of heavy vehicles do not always respond in the most eager way to the adoption of new, innovative technologies and services that would change their daily business routine and thinking. The concept of continuous monitoring and even more of enforcement may not be well accepted, especially by drivers with long experience in the field. Before the system commercialization, a deeper investigation on the User Interface aspects, especially those ones concerning the drivers, should be realized, to assure intuitiveness and user acceptance.

In the meanwhile, and as already stated in the Pan-European workshop of GOOD ROUTE-EURIDICE in Lucerne, it will be difficult to approach the drivers that work for themselves (and not on behalf of a company), which, however, comprise a considerable share of this market.

- **Research focus on European and international level shifting from safety to the environmental protection**

Due to the large scale environmental damage of the last decade and the multiple impacts for the quality of all kinds of life, research and business interest has been shifted from safety and the “0 accidents” vision to environmental protection and the “0 emissions” vision. The GOOD ROUTE system, as it currently stands, does not yet focus on environmental issues, although any DG accident may have extremely negative environmental impacts. However, the possibility of widening its scope, to take into account environmental aspects as contributing factors for the estimation of the (combined) minimum risk route, is a promising asset of the system.

- **Economic recession**

Economic recession will reduce the available social and private funds that could be used for setting up and maintaining GOOD ROUTE-like services. On the other hand though, it will enhance the need for reducing the costs related to transport operation delays, fuel consumption, loss of human lives and infrastructure damage, thus it may also constitute an opportunity for GOOD ROUTE.

- **Competition**

Several other competing platforms are there in the cooperative safety systems area, even if they do not address the exact same targets (i.e. those of CVIS, SAFETUNNEL), while some Fleet Management Systems may provide part of the GOOD ROUTE solutions, thus good consolidation, synergies and common interfaces rather than fierce antagonism and further market fractionisation are required.

1.1.6. Dissemination and Use

The full dissemination and exploitation activities of GOOD ROUTE are thoroughly presented in Chapter 2 of this document, namely “Final Plan for Using and Disseminating the Knowledge”.

1.1.6.1. Project Communication material

The following material has been produced in the context of GOOD ROUTE:

- The GOOD ROUTE project logo.
- The GOOD ROUTE leaflet and the GOOD ROUTE poster, which have printed in glossy paper (2000 leaflets and 500 posters) and have been distributed by the GOOD ROUTE Co-ordinator to all Partners.
- The GOOD ROUTE web-site, which is uploaded to the URL: www.goodroute-eu.org.
- The Project Fact Sheet, which includes info for the project objectives and expected results, available also in German, French, Finnish, Italian, Spanish and Greek.
- 6 electronic Newsletters presenting the progress of the project since the first year of its life have been produced.
- A project video presenting the GOOD ROUTE objectives and results has been produced.

Throughout its whole duration, the GOOD ROUTE website was being updated in a regular basis with announcements on upcoming events, achievements, etc. relevant to the GOOD ROUTE project. The project’s results can be found on the relevant section of the website, while the users of the website are able to download the public Deliverables of the project from this section.

The GOOD ROUTE User Forum, established from the first year of the project, was further enriched during the third year, in view of the final event and Pilots of GOOD ROUTE, consisting finally of around 100 members. The User Forum members were invited to all dissemination events organised by GOOD ROUTE, were sent the project Deliverables, whilst participants of the Pilots were recruited from them.

1.1.6.2. Other Dissemination Actions

During the first year of GOOD ROUTE, a Greek language workshop and a Pan-European workshop were held on 13.04.06 and 08.09.06 respectively for the communication of the project objectives and the identification of the relevant actors’ user needs and the project Use Cases. Finally, GOOD ROUTE had participated in the three EC concertation meetings, namely “ICT for Transport” (two of them) and “ICT for safety mobility”.

No workshop was planned for the second year of the project; however the GOOD ROUTE (CERTH/HIT) participated in the second meeting of the “ENT12 Tracking and Tracing of

Dangerous Goods”, presenting the activities of the project and establishing links with the Action Groups members.

The joint GOOD ROUTE and EURIDICE International workshop, with the support of SMARTFREIGHT and ROADIDEA European Projects, entitled “ICT in Transport Logistics” has taken place during the 3rd Year of the project). The workshop was held at Lucerne, Switzerland, from Monday the 3rd of November to Wednesday the 5th of November 2008, attracting around 70 participants. The first day of the joint workshop was devoted to the demonstration of the GOOD ROUTE system and the GOOD ROUTE vehicle demonstrator, whereas a visit to the Gotthard tunnel took place, so as to allow the demonstration of the project use cases. The second day was devoted to joint GOOD ROUTE and EURIDICE workshop sessions and key note sessions. The third day of the workshop has been devoted to the EURIDICE business forum kick off meeting. The workshop was successfully closed with a networking cocktail and guided tour in the Transport Museum of Lucerne. The minutes of the workshop have been synthesised by EURIDICE project, incorporating GOOD ROUTE contribution. The workshop has been strongly disseminated via the project web site, since the agenda and on-line registration was provided through it.

All dissemination activities carried out during each year of GOOD ROUTE are outlined in the following table.

Date	Type	Type of audience	Size of audience	Countries addressed	Responsible/involving Partner(s)/ Author(s)
First year of GOOD ROUTE (2006)-[01/01/06-31/12/06]					
Final: May 2006 (operational since March 2006)	Project web site	Public/Research	-	Worldwide	ICCS, USTUTT
Final: May 2006 (draft existing since March 2006)	Project Posters/flyers	Public/Research	-	EU countries	ICCS
19/07/06	1 st electronic project Newsletter	Public/Research	-	EU countries	ICCS
April 2006 as part of D10.2	Project fact sheet (translated also to German, French, Finnish, Italian, Spanish and Greek).	EC/Public/Research	-	EU countries	CERTH, COAT, FINRE, CRF, UPM
08/09/06	DSS Demo presented in Pan-European workshop in Stuttgart.	Public/Research	-	EU countries	CERTH/ITI
13/04/06	Greek language workshop in Athens for Expert Opinion Collection.	Public/Research	12 Greek experts	Greece	ELPA, CERTH-HIT, ICCS
08/09/06	1 st Pan-European Workshop entitled „Taking the safest route; The GOOD ROUTE initiative” for expert opinion collection.	Public/Research/Public Authorities	31 European experts	EU countries	CERTH, ICCS, USTUTT
05-06/07/06	1 st EU concertation meeting dealing with ICT for Transport.	EU/Research		EU countries	CERTH/ITI-CERTH/HIT
25-26/09/06	Workshop on "ICT for Safer	EU/		EU	CERTH/ITI

Date	Type	Type of audience	Size of audience	Countries addressed	Responsible/involved Partner(s)/ Author(s)
	Mobility" - Brussels, 26/09/2006	Research		countries	
05-06/07/06	2nd EU concertation meeting dealing with ICT for Transport.	EU/Research		EU countries	CERTH/ITI
October 2006	Full paper in ITS London 2006. "Dangerous Goods Transportation Routing, Monitoring and Enforcement". Authors: Dimitrios Tzovaras (CERTH/ITI), Evangelos Bekiaris, Maria Gemou (CERTH/HIT).	EU/Public/Research/Industry	-	EU countries	CERTH/HIT
First: 21/12/05 Further releases: 22/12/05; 23/12/05; 31/12/05;11/01/06	Press Release of ELPA: Shield in DG transportation", Athens, KERDOS, p13. Other releases: "ELPA: Safety Actions", TRAFFIC, p41. "Measures for the reduction of traffic accidents", NIKI, p11. "ELPA participation in project aiming at the reduction of traffic accidents", EXPRES, p40. "Project for the reduction of traffic accidents", ANO KATO KIRIAKIS, p7. "Project for the reduction of traffic accidents", AUTO TRITI, p21.	National/Public	-	Greece	ELPA
January 2007	"Need for systematic support and guidance of DG vehicles transits and emergency service", Supply chain & Logistics Magazine, Issue: January 2007.	Public/National	-	Greece	CERTH/HIT
Second year of GOOD ROUTE (2007)-[01/01/07-31/12/07]					
15/01/07	2nd project electronic Newsletter	Public/Research	-	EU countries	ICCS
12-13/02/07	Participation in "ENT12 Tracking and Tracing of Dangerous Goods" Second meeting presenting the activities of GOOD ROUTE and establishing links with the Action Groups members.	Research	-	European-Regional	CERTH/HIT
18-20/06/07	"Real Time Decision Support System for the Routing of Dangerous Goods Vehicles". Authors: A. Patrinos, V. Emmanoulidis, D. Tzovaras and E. Bekiaris. Presented in IIS Europe, Aalborg 2007.	Public/Research/Industry	-	Europe	CERTH
23-27/07/07	Camera-ready paper in UAHCI Conference, Beijing 2007. "HCI concepts for the future driver".	Public/Research/Industry	-	Worldwide	USTUTT, CERTH/HIT

Date	Type	Type of audience	Size of audience	Countries addressed	Responsible/involved Partner(s)/ Author(s)
	Authors: Dr. Marco Santi, Dr. Harald Wildroither and Dr. Evangelos Bekiaris (CERTH/HIT)				
13/11/2007	3rd project electronic Newsletter	Public/Research	-	EU countries	ICCS
11/12/07	Article in DVZ – Deutsche Verkehrszeitung „Informationen sollen Risiken senken“. Author: Mr. Jan-Paul Leuteritz (USTUTT)	Public / National	-	Germany	USTUTT
Third year of GOOD ROUTE (2008)-[01/01/08-31/01/09]					
January 2008	4th project electronic Newsletter	Public/Research	-	EU countries	ICCS
05–07/03/08	Camera ready paper and presentation in The Fully Networked Car Workshop, held in Geneva, “Resource allocation in dangerous goods transportation environments”, by Martín, G., Los Santos, A (TID).	Research	-	Worldwide	TID
21-24/04/08	Camera-ready paper and presentation in TRA 2008 conference in April 2008 in Ljubljana, Slovenia. Title: “A real time decision support system for the safe and efficient routing of dangerous goods vehicles”. Authors: V. Emmanouilidis, A. J. Patrinos, D. Tzovaras (CERTH/ITI), M. Gemou, E. Bekiaris (CERTH/HIT).	Public/Research	-	Worldwide	CERTH
27-31/05/08	Camera-ready paper and presentation in 10th International Conference on Applications of Advanced Technologies in Transportation (AATT 2008), Athens, Greece “The GOOD ROUTE System Architecture for Dangerous Goods Road Transportation”, by Pagle K., Amditis A., Bianconi P., Kauber M. (Presentation by Katia Pagle, ICCS).	Public/Research	-	Worldwide	ICCS,PTV, CRF
27-31/05/08	Camera-ready paper and presentation in 4th International Congress on Transportation Research in Greece at 27-31 May 2008. Title: “A common and modular ontological framework for the dangerous goods transportation logistic chain”. Authors: M.Gemou, E. Bekiaris (CERTH/HIT)	Public/Research	-	Worldwide	CERTH/HIT
4-6/06/08	Camera ready paper and presentation to ITS Europe 2008, Geneva, “System architecture principles for safe transportation of dangerous goods; the good route approach”, by Pagle, K., Amditis, A., Bekiaris, E.,	Public, Research	-	Europe	ICCS, CERTH

Date	Type	Type of audience	Size of audience	Countries addressed	Responsible/involved Partner(s)/ Author(s)
	Gemou, M., Tzovaras, D.				
September 2008	5th project electronic Newsletter	Public/Research	-	EU countries	ICCS
22-24/10/08	Camera-ready paper and presentation to eChallenges e-2008 Conference, in Stockholm on 22-24 October 2008. Title: "Decision Support System for the Safest and Most Cost-Efficient Routing of Dangerous Goods Vehicles", by Emmanouilidis, V., Tzovaras, D., Bekiaris, A., Gemou, M., Centre for Research and Technology Hellas, Greece.	Public, Research	-	Europe	CERTH/ITI, CERTH/HIT
October 2008	Article related to Conflict Resolution Module included in Telecom I+D conference proceedings held in Bilbao in October 2008: "Modulo de Resolución de Conflictos para DGVs de GoodRoute" (Conflict Resolution Module for DGVs in GOOD ROUTE). Author: Gregorio Martín (Telefonica I+D).	Public, Research	-	Europe	TID
03-05 November 2008	"ICT in Transport Logistics", Lucerne, Switzerland	Public, Industry, Research	Around 70 persons	Europe	All GOOD ROUTE Partners
January 2009	6th project electronic Newsletter	Public/Research	-	EU countries	ICCS
30 January 2009	Final project video	Any type	-	Any country	ICCS

Table 10: GOOD ROUTE dissemination activities.

1.1.6.3. *Exploitation Knowledge and its Use*

There are 6 exploitable products identified in GOOD ROUTE, as follows:

- Minimum Risk Route Guidance System (D2.2, D2.1)
- OBU (D3.2)
- Control Centre and Logistic chain support modules (D4.2, D4.1)
- Enforcement System (D5.2)
- GOOD ROUTE vehicle platform (D6.3)
- GOOD ROUTE integrated system and service (D6.2)

The GOOD ROUTE value chain is evident in the following figure.

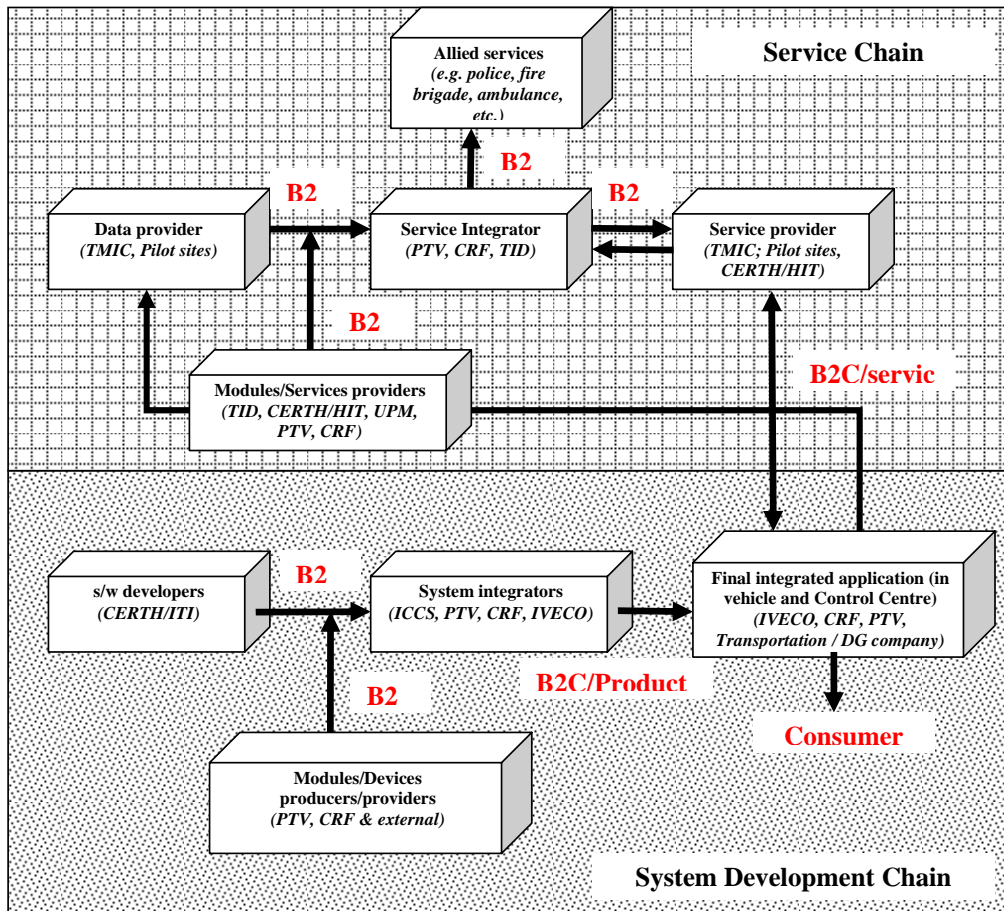

Figure 64: GOOD ROUTE value chain.

The overview of the GOOD ROUTE Exploitation Products is provided in the following table.

Project exploitable result	Relevant Exploitable knowledge	Main Exploitation Partner	Type of product	Main Responsible Partner profile	Prototype available	Time to Market (after the end of the project)	Target Market	Respective Role depicted in Error! Reference source not found.
Minimum Risk Route Guidance System (D2.2, D2.1)	Risk Estimation and DSS Algorithms	PTV & CERTH/ITI	s/w and service	Major route guidance system developer.	M29-May 2008	12 months	ADR transportation companies	PTV acting as system integrator of the minimum risk route guidance system and CERTH/ITI as s/w provider.
OBU (D3.2)	-	IVECO & CRF	s/w and h/w	Major truck manufacturer.	M29-May 2008	12 months	ADR vehicles	CRF acting module/device producer/provider with regard to the OBU and the respective sensors and IVECO as system integrator .
Control Centre and Logistic chain	Semantic Service Network and data	PTV (with the support of TID and	Service, s/w and h/w	Major developer and TMC supplier.	M29-May 2008	12 months	All actors of the logistic	PTV acting as module/device provider and as system

Project exploitable result	Relevant Exploitable knowledge	Main Exploitation Partner	Type of product	Main Responsible Partner profile	Prototype available	Time to Market (after the end of the project)	Target Market	Respective Role depicted in Error! Reference source not found.
support modules (D4.2, D4.1)	fusion algorithms, GR ontological framework	CERTH/HIT)					chain (i.e. TMC & ADR owners)	integrator. TID and CERTH/HIT acting as module/service providers.
Enforcement System (D5.2)	-	CRF & UPM	s/w and h/w	Major telematic systems supplied & Local Node system developer	M29-May 2008	24 months	Authorities	CRF acting as module/service provider (with possible outsourcing). LST/UPM acting as module developer (with royalties).
GOOD ROUTE vehicle platform (D6.3)	-	IVECO & CRF	s/w and h/w, integrated on	Major truck manufacturer (IVECO) and automotive services provider	M29-May 2008	24 months	ADR transportation companies	IVECO acting as system integrator and carrier of the final integrated

Project exploitable result	Relevant Exploitable knowledge	Main Exploitation Partner	Type of product	Main Responsible Partner profile	Prototype available	Time to Market (after the end of the project)	Target Market	Respective Role depicted in Error! Reference source not found.
			vehicles	(CRF)				application in vehicle, supported by CRF.
GOOD ROUTE integrated system and service (D6.2)		PTV (with the support of CRF)	s/w and h/w, integrated at local TMC and provision of service	TMC and telematic solutions system developer	M29-May 2008	24 months	TMC of all types of infrastructure	PTV is co-developer/operator of several TMC's (i.e. Bavaria) and CRF is equipping several infrastructures with telematic systems (i.e. Trento).

Table 11: GOOD ROUTE Exploitable plans.

Provided the competitive market context urging for robust and mature applications able to penetrate into the market as fast as possible, the following roadmap has been envisaged for GOOD ROUTE exploitation.

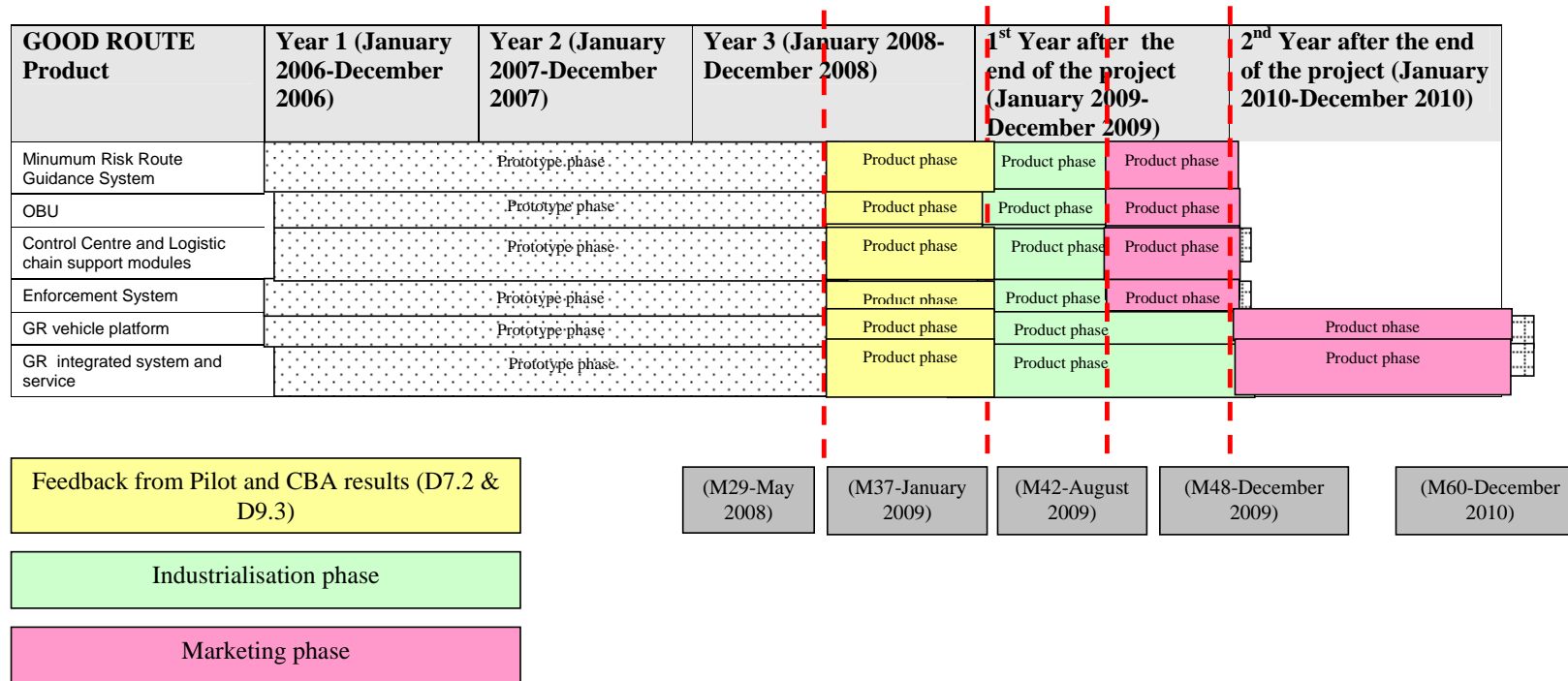

Figure 65: GOOD ROUTE exploitation roadmap.

As it is shown in the above figure, all products of GOOD ROUTE, considered as exploitable, are currently available as prototypes and have been assessed in the context of the scheduled Pilots. Right after the prototype phase, the product phase follows, which is distinguished in three sub-phases, namely the phase where the prototypes are optimized upon the results of the Pilots (taking also feedback from the Cost Effectiveness and Cost Benefit results, when applicable), the industrialization phase, and finally, the marketing phase. As it is obvious, for the standalone products, like the Minimum Risk Route Guidance system or the enforcement system, etc., the industrialization phase is foreseen to be completed much earlier than for the vehicle platform and the integrated system and service. Thus, the marketing phase for the vehicle platform and the integrated service is expected to start around the beginning of the second year after the end of the project (January 2010) and end around December 2010.

There are three Business Cases identified in GOOD ROUTE, as follows.

- **Deployment Scenario 1: Operation for LC's internal purposes**

In this case, a GOOD ROUTE system is implemented by a (group of) Logistic Company(s) to facilitate planning and monitoring of dangerous goods transports. It is adopted (on a voluntary basis) as an enhanced safety measure, to improve the efficiency and reduce the cost of the operation.

The GOOD ROUTE system can be conceived as a specialisation of client server systems for integrated tour planning, server guided⁵ truck navigation and monitoring, of which maps are extended for Dangerous Goods features and minimum risk evaluation algorithms.

Infrastructure operators have no or only a limited role in this scenario, being not the prime initiator of the system they might collaborate supplying up to date information on travel/passage times and events, as well as other details as far as in their interest and benefit from some knowledge on the specific trips of the DG vehicles monitored by the system.

Market penetration is expected to remain low (only large hauliers to be involved in otherwise private operation).

Application scenarios which may be deployed under this scenario:

- Minimal Risk routing & monitoring
- To a very limited extent: passport of infrastructure passage

⁵ The route is determined in the service centre (equivalent to GOOD ROUTEs Control Centre) and transferred to the navigation client.

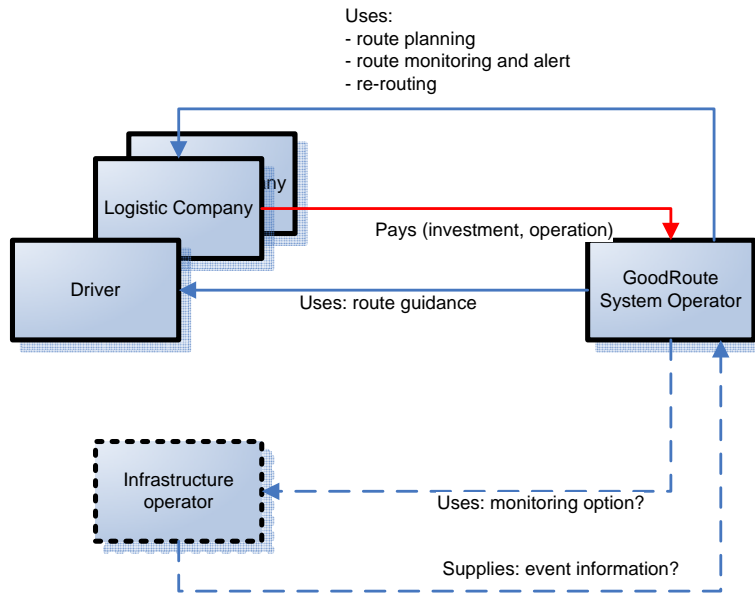

Figure 66: Value chain for deployment scenario 1.

- **Deployment Scenario 2: Operation by specific IO's for voluntarily use by LCs**

In this case, the GOOD ROUTE system will be introduced by specific infrastructure operators in order to manage access or give priority of access or guarantee fast access (without escorting) or reduced fees, etc. The adoption of the system is voluntary and will be undertaken by selected transporters and dispatchers, of high volumes. The more infrastructure operators adopt such a (harmonised) system the more attractive it will become for transporters/dispatchers to adopt such a system.

As for Deployment scenario 1, the GOOD ROUTE system can be conceived as a specialisation of client server systems for integrated tour planning, server guided⁶ truck navigation and monitoring, of which maps are extended for Dangerous Goods features and minimum risk evaluation algorithms. In addition, OBUs (providing vehicle status information as well as billing functionalities) are supplied to DG LC as truck equipment and local node equipment is implemented at the infrastructure for vehicle status monitoring and enforcement support.

A gradual market penetration is foreseen comparable e.g. to the introduction of automated tolling at Brenner or on French motorways, but focused on DG vehicles, which may choose to equip their vehicles and use GOOD ROUTE procedures (or continue without). The volume and growth is directly related with the number and the importance of the infrastructure operators involved.

⁶ The route is determined in the service centre (equivalent to GOOD ROUTE's Control Centre) and transferred to the navigation client.

All application scenarios may be deployed in this case:

- Minimal Risk routing & monitoring
- Passport for infrastructure passage
- Efficient enforcement of legal compliance may only implemented in a limited way, i.e. those vehicles equipped with OBU's may be exempt from manual controls and may be offered more rapid processing (as incentive for GOOD ROUTE system use).

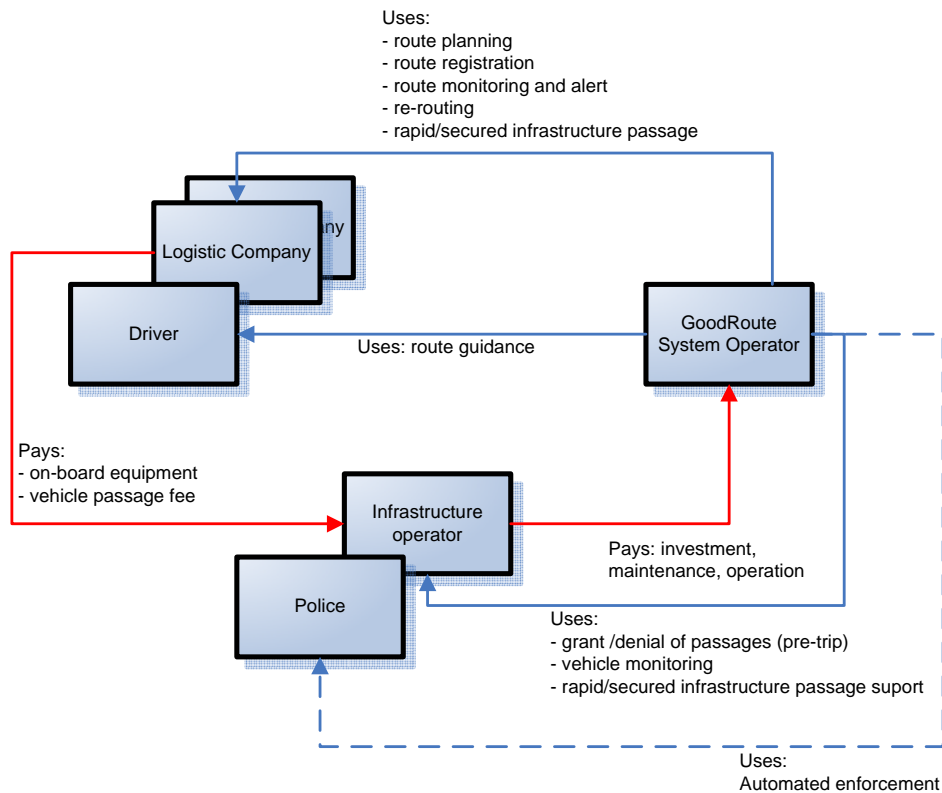

Figure 67: Value chain for deployment scenario 2.

• Deployment Scenario 3: Mandatory use

GOOD ROUTE is introduced by specific infrastructure or for whole areas/countries as mandatory for all ADR vehicles or some classes of them.

The system is equivalent to that in Deployment Scenario 2, though extended for enforcement features.

Fast market penetration is expected in this case (from 50% to 100%, depending upon the type of law restrictions; i.e. local vs. national).

Scenarios/functions which may be deployed under this scenario:

- Minimal Risk routing & monitoring

- Passport for infrastructure passage
- Efficient enforcement of legal compliance

The value chain is very similar to Scenario 2.

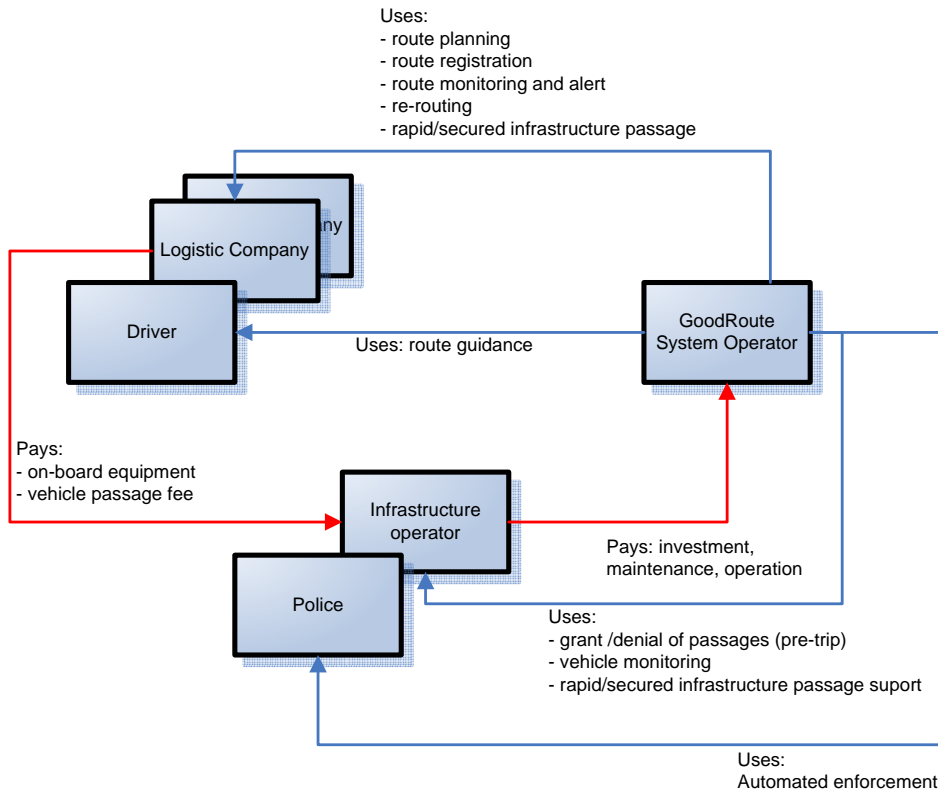

Figure 68: Value chain for deployment scenario 3.

For further analysis on the business part, please refer to D9.3: “CBA and CEA on developed applications”.

No right protection actions or patents are foreseen by the GOOD ROYTE Consortium. Applications will be part of patented and trademarked products (please see D9.4: “Exploitation and Business Plans” and below for further details). The publishable summary of each exploitable result the project has generated is provided below.

Minimum Risk Route Guidance System

The minimal risk route guidance system is a hybrid guidance system, which takes into account static and dynamic data for route optimization. In specific safety critical aspects, infrastructure capacity, risk analysis algorithms, different social and business group demands and conflict resolution between enterprises are taken into account during server side route optimisation. The resulting route is provided to in-vehicle clients to offer dynamic minimum risk routing and re- routing for dangerous good trucks.

The main innovative feature of the Minimum Risk Route Guidance System is the web service – oriented implementation which provides interoperability between different providers, ensures the transparent integration to new or existing systems and enables the system extension with new functionalities.

PTV and CERTH/ITI are envisaging the further exploitation of the Minimum Risk Route Guidance System and its components as well as their extension in other relevant research and industrial projects. A final version of the product will be offered to the market through PTV and adapted for other relevant markets through a spin-off company of CERTH/ITI. The product will be licensed as part of a guidance system for dynamic routing, according to individual and societal risk factors.

Contact Details

Michael Landwehr
Manager ITS Systems
Research&Innovation - Mobility Systems
PTV AG
Planung Transport Verkehr AG
Stumpfstraße 1
76131 Karlsruhe
Germany
Tel.: +49 721 9651-541
Fax: +49 721 9651-699
E-Mail: michael.landwehr@ptv.de
<http://www.ptv.de>; <http://www.ptv-vision.de>

Dr. Dimitrios Tzovaras
Electrical Engineer, Ph.D.
Researcher Grade B (Associate Professor)
Informatics and Telematics Institute
Centre for Research and Technology Hellas
6th Km Charilaou-Thermi Road
57001 (PO Box 60361)
Thermi-Thessaloniki, Greece
Tel. : +302311-257777
Fax : +30-2310-474128
E-mail : Dimitrios.Tzovaras@iti.gr
<http://www.iti.gr/>

OBU

The OBU is based in the Blue&Me™ device developed by Fiat Auto, Magneti Marelli and Microsoft Automotive Business Unit, an innovative solution, based on Windows Mobile for Automotive, which performs in-car communication, information, and entertainment functionalities. Blue&Me includes a voice command system, completely integrated into the vehicle, and an information display. An advanced voice recognition system immediately reads incoming SMS messages aloud.

The OBU hardware main features are the following:

- 2 high speed CAN interfaces (C-CAN) for vehicle CAN connection
- 1 low speed CAN interface (B-CAN) for HMI management
- Bluetooth device for short range wireless communication
- GPRS device for long range wireless communication
- GPS device for positioning and navigation
- USB interface

The main functionalities of the OBU are the following:

- To monitor vehicle operating parameters.
- To monitor driver behaviour.
- To provide position information to the navigation subsystem.
- To receive the status of the goods in the cargo, to handle the status and provide warning to the driver in case of specific events.
- To interface TPMS sensor and provide information on the wheel status.
- To manage HMI with the driver.

Possible market applications: The OBU can be used on all commercial vehicles, including the ones carrying dangerous goods.

Stage of development: The OBU is currently developed as a prototype for demonstrator applications.

Contact details

Bianconi Maria Paola
Centro Ricerche Fiat
Infomobility
Tel.: +39 011 9083782
Fax: +39 011 9083083
Mobile: +39 3351302591
E-Mail: mariapaola.bianconi@crf.it

Control Centre and Logistic chain support modules

Web-frontend and business logic representing an integrated workflow for different stakeholders related to dangerous goods for infrastructure passage planning, prioritisation and monitoring, embedding algorithms making up the Semantics Service Network (SSN) of the logistic support system (LSS) and those that constitute the Data Fusion module of GOOD ROUTE Control Center (CC).

The Control Center is made of a frontend (Portal) and a backend. The backend architecture consists of two modules: the business logic that handles the general tasks like the profile and map management, and the data fusion, that takes care of all the incoming messages and their correct fusion and distribution.

Beyond the specific implementation, knowledge has been generated on handling complex multistakeholder workflows in the area of route planning and monitoring. PTV has developed this prototype based on its commercialized routing, mapping and geocoding web-server suite. The prototype of the Control Centre and Logistic chain support modules allows to gain insight in the potential and the limits to support complex workflows involving several stakeholders. It allows to gain further domain knowledge in

the specific area of infrastructure passage management and dangerous goods. In this direction, PTV intends to further use the demonstrator as basis for its next generation of implementations in this area.

Contact Details

Michael Landwehr
Manager ITS Systems
Research&Innovation - Mobility Systems
PTV AG
Planung Transport Verkehr AG
Stumpfstraße 1
76131 Karlsruhe
Germany
Tel.: +49 721 9651-541
Fax: +49 721 9651-699
E-Mail: michael.landwehr@ptv.de
<http://www.ptv.de>; <http://www.ptv-vision.de>

Jorge Serna
Manager Ambient Intelligent Systems
Telefonica I+D
Emilio Vargas 6
28043 Madrid
Spain
Tel.: +34 91 337 4503
E-Mail: jserna@tid.es
<https://www.tid.es/netvehicles/home.htm>

Dr. Georgia Aifadopoulou
Principal Researcher
Head of Unit “Intelligent Infrastructure & Demand Management”
Centre for Research and Technology Hellas (CERTH)/
Hellenic Institute of Transport (HIT)
6th km Charilaou – Themi Rd., P.O.Box: 60361, P.S.:
57001,
Themi, Thessaloniki, Greece
Tel.: +30 2310 498 457, FAX: +30 2310 498 269
e-Mail: gea@certh.gr
Web Site: www.hit.certh.gr

Enforcement System

The results obtained by the Enforcement System during the pilot’ tests have demonstrated the high capability and potentiality of this product. A main advantage for road safety could be reached by introducing the automatic enforcement scenario in highways and roads, both for the normal vehicles and especially for trucks carrying dangerous goods. One of the innovative aspects in enforcement is the readiness of the system in checking the vehicles’ parameters, in reacting to any possible violation the system traces and informing the local authority about the violation. The intervention’s

velocity achieved by the system makes the GOOD ROUTE enforcement the only existing platform able to quickly stand over the vehicles through a total control of all vehicle's parameters the local node has been arranged to check over and in several types of scenarios. It is possible to consider several practical cases in order to endorse this as:

- Improvement of truck's control in goods' transport (even if they are dangerous goods) between two countries, generally subject to long queues;
- Improvement of vehicles control before any other particular situation due to the roads, as a tunnel or a bridge;
- Possibility patrol cops to let any patrol cop equipped by a mobile enforcement check any vehicles without stopping it, but just approaching it.

The Local Node product is aimed to be used by the motorway companies or any other organization involved in highways and roads management and safety of the road network (i.e. Police).

The usage of the enforcement platform, referring to the local node enforcement unit, should request low production and maintenance cost. A higher cost could incur from the truck's side, since it must be equipped respectively in order to communicate with the local node.

Among the several benefit the enforcement use and commercial investment can bring for is the possibility to reduce the technical staff in charge of the highway safety and management and only limited a trained staff to the supervision of the local node unit, in order to assure the correct functioning of the antenna and the others hardware device.

Local Node versatility and portability properties make the system fairly appropriate to penetrate into the market. In order to be commercialised and industrialised, it needs certainly to be further studied, optimized and fortified according to the commercial standards, since the modern telematics and intelligent transport systems demand robust and fast broadband communications for ITS applications.

UPM, as developer and producer of the Local Node enforcement system is retaining the royalties on the overall gross price for the duration of this agreement. The same is valid for CRF for the vehicle part of the enforcement system.

Contact details

Bianconi Maria Paola
Centro Ricerche Fiat
Infomobility
Tel.: +39 011 9083782
Fax: +39 011 9083083
Mobile: +39 3351302591
E-Mail: mariapaola.bianconi@crf.it

Alessio Fioravanti
LST - Life Supporting Technologies

email: afioravanti@lst.tfo.upm.es
web: ETSI Telecomunicación
http://www.lst.tfo.upm.es
phone: (+34) 91 549 57 00 (ext. 8015)
Ciudad Universitaria s/n. 28040 Madrid, Spain.
Universidad Politécnica de Madrid
fax:(+34) 91 336 68 28

GOOD ROUTE vehicle platform

GOOD ROUTE vehicle platform is a vehicle platform, equipped with sensors and encompassing OBU, nomadic device interface, local node interface and any other in-vehicle functionalities required for the overall operation of the GOOD ROUTE system. IVECO, a major truck manufacturer will enable the GOOD ROUTE platform to operate in its vehicles.

IVECO will launch its telematic OBU's services in the next few years, with a different approach for its two main classes of products:

- for the light commercial vehicles, a telematic platform similar to FIAT's one will be installed, with display integrated into the dashboard and steering commands for the driver's input.
- for the medium and heavy trucks, an ad hoc version of the telematic unit has been developed to support basically:
 - 24V power supply;
 - 2 high speed CAN busses;
 - An enhanced front panel with display.

Further work is needed during industrialisation for the full integration of GOOD ROUTE functions into the above two IVECO service architectures. Also, the interface will be integrated and not divided into nomad device and OBU ones, as in the prototype version. IPR is solved by integration of GOOD ROUTE platform inside the patented and trademarked IVECO platform.

Contact details

Giandomenico Fioretti
IVECO
Manufacturing & Product
Product Management
Via Puglia 35
10156 Torino - Italy
Tel.: +39 011 0072798
Fax: +39 011 0074844
E-mail: giandomenico.fioretti@iveco.com

GOOD ROUTE integrated system and service

GOOD ROUTE integrated system and service is a web service, allowing the full operation of GOOD ROUTE functionality and the relevant nomadic and on-board devices to connect to it.

PTV will set up and maintain all service related platforms, whereas CRF will support (through cooperation with other FIAT group companies, such as Magneti Marelli and IVECO) the devices to be operated.

Results will be exploited by being integrated into existing PTV and Fiat (Blue&Me) product services.

Additional work will be performed mainly on the integration of GOOD ROUTE functionality to those existing platforms and into the PTV and Fiat commercialization chains.

Each Partner holds IPRs for the different part it developed. No further patents planned. Work so far concentrated mainly to internal contacts between the R&D departments of PTV and CRF and the production and marketing departments of PTV, IVECO and Magneti Marelli.

Contact Details

Michael Landwehr
Manager ITS Systems
Research&Innovation - Mobility Systems
PTV AG
Planung Transport Verkehr AG
Stumpfstraße 1
76131 Karlsruhe
Germany
Tel.: +49 721 9651-541
Fax: +49 721 9651-699
E-Mail: michael.landwehr@ptv.de
<http://www.ptv.de>; <http://www.ptv-vision.de>

Bianconi Maria Paola
Centro Ricerche Fiat
Infomobility
Tel.: +39 011 9083782
Fax: +39 011 9083083
Mobile: +39 3351302591
E-Mail: mariapaola.bianconi@crf.it

The final exploitation plans are provided in D9.4: "Exploitation and Business Plans", released in the 3rd Year of the project. Final exploitation plans have been formulated upon the Consortium Exploitation Agreement, which is currently under signature process. For further details on Exploitation, please see Chapter 2 of this document.

Annex 1: Training Schemes for DG Drivers and Infrastructure Operators

GOOD ROUTE Training Curriculum for Drivers Totally: Max. 26 training hours⁷
Assessment of the physical and the mental condition of the drivers
Each Training Day Foreground (15-30 minutes)
<ul style="list-style-type: none"> ◆ Introduction ◆ Schedule of the training day ◆ Informal conversation ◆ Observation of social behaviour ◆ Review of the last training session taught the previous day, if applicable
<u>1. BASIC COURSE (12 ½ teaching hours)</u>
<u>BASIC COURSE –Theoretical Part (about 9 teaching hours)</u>
Training courses realised on national level including:
1. <i>General requirements governing the carriage of dangerous goods (1 teaching hour)</i>
<u>“GOOD ROUTE training sessions”</u>
<u>Scenarios: Introduction to safety systems (ADAS, IVIS, etc.); GOOD ROUTE functionalities (20 minutes)</u>
Training courses realised on national level including:
2. <i>Traffic Laws</i>
3. <i>General information concerning civil liability and other legal issues including the necessary documents and safety equipment, which must accompany transport of dangerous goods and the compliance of such documents and equipment with the regulations; (1 teaching hour totally)</i>
<u>“GOOD ROUTE training sessions”</u>
<u>Scenarios: National Schemes related to ADR transportation in key infrastructures (tunnels, bridges, etc.) (45 minutes)</u>
Training courses realised on national level including:
4. <i>Main types of hazard;</i>
5. <i>Preventive and safety measures appropriate to the various types of hazard;</i>
6. <i>Marking, labeling, placarding and orange-coloured plate marking requirements and performance ways;</i>
7. <i>Information on multimodal transport operations; Handling and stowage of packages;</i>
<i>(1 ½ teaching hour totally)</i>
<u>“GOOD ROUTE training sessions”</u>
<u>Scenarios: GOOD ROUTE ontologies (30 minutes)</u>

⁷ One training hour corresponds to 45 minutes.

GOOD ROUTE Training Curriculum for Drivers Totally: Max. 26 training hours⁷
<p style="text-align: center;">Training courses realised on national level including:</p> <p>8. <i>What a driver should and should not do during the carriage of dangerous goods.</i> 9. <i>Information on environmental protection in the control of the transfer of wastes;</i> 10. <i>What to do after an incident/accident that may affect safety during the transport, loading or unloading of dangerous goods (first aid, road safety, basic knowledge about the use of protective equipment, etc.); (60 minutes totally)</i></p>
<p>“GOOD ROUTE training sessions” Scenarios: Emergency functionalities (45 minutes)</p>
<p style="text-align: center;">Training courses realised on national level including:</p> <p>11. <i>Purpose and the method of operation of technical equipment on vehicles;</i> 12. <i>Acquaintance with technical parts of the vehicle and basic principles of function, maintenance and recovery;</i> 13. <i>Prohibitions on mixed in the same vehicle or container;</i> 14. <i>Precautions to be taken during loading and unloading of dangerous goods;</i> <i>(1 teaching hour totally)</i></p>
<p>“GOOD ROUTE training sessions” Scenarios: Navigation, Routing, Re-routing and OBU (45 minutes)</p>
<p style="text-align: center;">Training courses realised on national level including:</p> <p>15. <i>Ethical Issues;</i> 16. <i>Management, Market issues and Customers’ Responsiveness issues;</i> Health and Fitness (including alcohol and medicine effects and potential impacts); <i>(45 minutes totally)</i></p>
<p>“GOOD ROUTE training sessions” Scenarios: Enforcement functionalities (15 minutes)</p>
<p style="text-align: center;">Training courses realised on national level including:</p> <p>17. <i>Preparing Accident Reports on serious accidents, incidents or serious infringements recorded during the transport, loading or unloading of dangerous goods.</i> <i>(15 minutes)</i></p>
BASIC COURSE –Practical Part- Case Studies (3 ½ teaching hours)
<p style="text-align: center;">Training courses realised on national level including:</p> <p>18. <i>Provision of first aid to themselves and other people;</i> 19. <i>Fire-fighting;</i> 20. <i>What to do in case of an incident or accident (Introduction for “ROAD SAFETY COURSE”)</i> 21. <i>Loading and unloading of dangerous goods, with use of real or mock-up on-the-job equipment;</i> 22. <i>Handling and stowage of packages, with use of real or mock-up on-the-job equipment;</i> 23. <i>Acquaintance with technical parts of the vehicle and basic principles of function, maintenance and recovery.</i> 24. <i>Check and Operation of technical equipment on vehicles, with use of real or mock-up on-the-job equipment;</i></p> <p style="text-align: center;"><u>Outside Vehicle Check (circle check)</u></p> <ul style="list-style-type: none"> ◆ <i>General Vehicle Characteristics</i> ◆ <i>Tyres</i>

GOOD ROUTE Training Curriculum for Drivers Totally: Max. 26 training hours⁷
<ul style="list-style-type: none"> ◆ <i>Tightening of wheel-nuts</i> ◆ <i>Lights</i> ◆ <i>Oil</i> ◆ <i>Water</i> ◆ <i>Fire extinguisher(s)</i> ◆ <i>ADR-equipment</i> ◆ <i>Outside cleanliness</i> <p><u>Inside Vehicle Check (circle check)</u></p> <ul style="list-style-type: none"> ◆ <i>Visibility check (including dead-angle camera/mirror and any obstructions of the line of sight)</i> ◆ <i>ADR-equipment</i> ◆ <i>Equipment specially needed for specific type of work</i> ◆ <i>Personal protective equipment (if applicable)</i> ◆ <i>Documents</i> ◆ <i>Fuel</i> ◆ <i>Dashboard check</i> ◆ <i>Safety belt</i> ◆ <i>Inside cleanliness</i> ◆ <i>Air-conditioning</i> ◆ <i>Music (there must be no possibility of changing CDs whilst driving)</i> ◆ <i>Adjusting of the seat/steering wheel to correct and make comfortable posture</i>
<u>ROAD SAFETY COURSE (around 12 teaching hours)</u>
<u>ROAD SAFETY COURSE-Theoretical Part (4 teaching hours)</u>
<p>Training courses realised on national level (if applicable) including:</p> <p>25. <i>Defensive Driving;</i></p> <p>26. <i>Antiskid;</i></p> <p>27. <i>Anti-rollover;</i></p> <p>28. <i>Fatigue Management;</i></p> <p>29. <i>Eco-Driving.</i></p> <p style="text-align: center;"><i>(up to 3 teaching hours totally)</i></p>
<p><u>“GOOD ROUTE training sessions”</u></p> <p><u>Scenarios: Safest routing (1 hour)</u></p>
<u>ROAD SAFETY COURSE-Practical Part (2 ½ hours and 4 hours totally)</u>
<p>Training courses realised on national level (if applicable) including:</p> <p>30. <i>Defensive Driving;</i></p> <p>31. <i>Antiskid;</i></p> <p>32. <i>Anti-rollover;</i></p> <p>33. <i>Fatigue Management;</i></p> <p>34. <i>Eco-Driving.</i></p>
<p><u>“GOOD ROUTE on the road training scheme”</u></p> <p><i>(maximum 4 hours including breaks)</i></p>
<u>EACH TRAINING DAY DEBRIEFING (15-30 minutes)</u>

GOOD ROUTE Training Curriculum for Drivers Totally: Max. 26 training hours⁷
<ul style="list-style-type: none"> ◆ Overall evaluation of the course/day ◆ Verification of checklist and observations (explanation of both positive and negative remarks) ◆ Identification of areas for improvement and suggested action(s) ◆ Remarks by the trainee (critique of the course) and signature by the trainee of the evaluation report ◆ Issue of final report by trainer (sent to the line manager of each trainee)

Figure 69: GOOD ROUTE training curriculum for DG drivers.

GOOD ROUTE Training Curriculum for Infrastructure Operators	
TMC Task Integral Function	Time Duration
F1. Provide Travel Information	2 teaching hours ⁸
GOOD ROUTE: Ontologies and interfaces to other modes of transport	1 teaching hour
F2. Records Management	1 teaching hour
GOOD ROUTE: Traffic safety data collection and management	1 teaching hour
F3. Congestion Management	1 teaching hour
F4. Failure Management	1 teaching hour
F5. Incident Management	1 teaching hour
F6. Special Event Management	1 teaching hour
GOOD ROUTE: Passport, routing and re-routing	2 teaching hours
F7. Traffic Flow Monitoring	1 teaching hour
F8. Emergency Management	1 teaching hour
GOOD ROUTE: Emergency functionalities	2 teaching hours
F9. Provide/Coordinate Service Patrols	1 teaching hour
F10. Reversible & HOV Lane	1 teaching hour
F11. Traffic Signal System Management	1 teaching hour

⁸ One training hour corresponds to 45 minutes.

GOOD ROUTE Training Curriculum for Infrastructure Operators	
F12. Transit Vehicle Monitoring	1 teaching hour
GOOD ROUTE: TMC and allied services monitoring and access levels	2 teaching hours
F13. APTS System Management	1 teaching hour
F14. Environmental & RWIS Monitoring	1 teaching hour
F15. Overheight Vehicle Management	1 teaching hour
GOOD ROUTE: Enforcement functionalities	1 teaching hour
F16. Rail Crossing Management	1 teaching hour
GOOD ROUTE: Control Centre operation and maintenance	3 teaching hours
GOOD ROUTE: On the job training	1 week to 6 months

Figure 70: GOOD ROUTE training curriculum for Infrastructure Operators.