

Fiber orientation based on a mould flow analyses

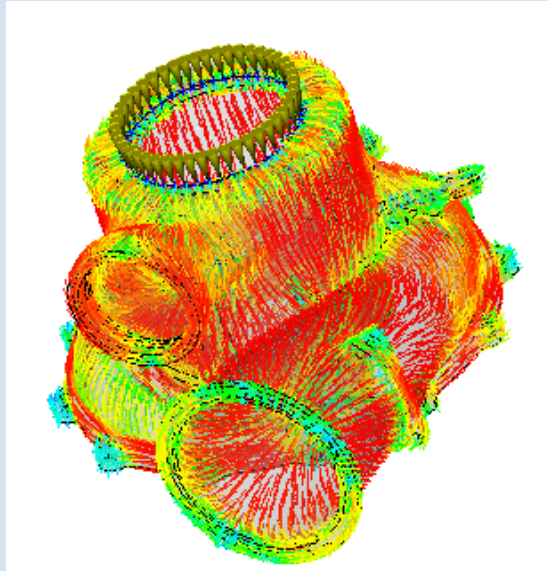

Filling time in seconds

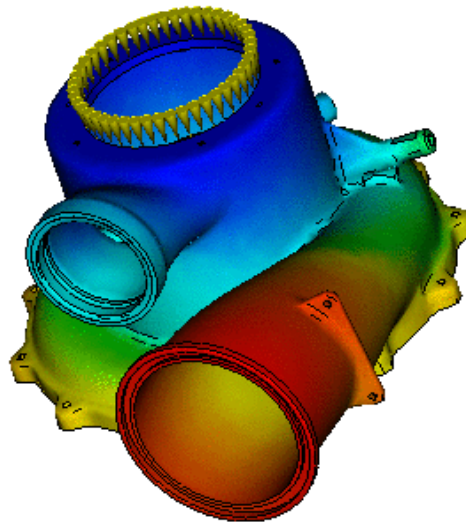

Mold design

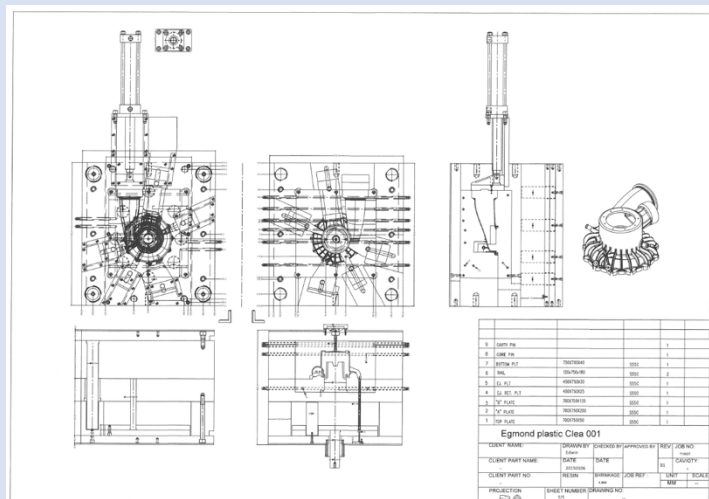

Mould in open position

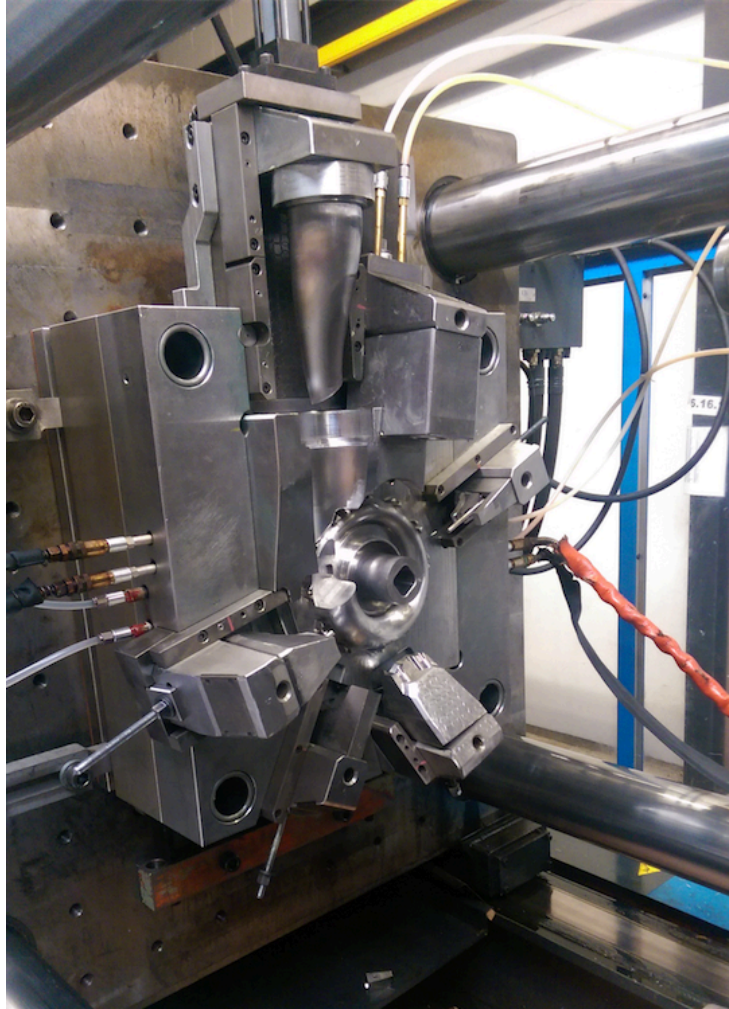

Final product moulded and post machined



**Final product post
machined and with
overmoulded inserts**

