



Project no. **TSA6-CT-2006\_044599**

Project acronym **EURO-TRANS\_Days**

Project title

**Promoting and facilitating the participation of SMEs in FP7 EU RTD projects in Surface Transport – automotive, railways, waterborne**

Instrument : **SSA**

Thematic Priority : **Sustainable development, global change and ecosystems**

**Final activity report**  
(from 1<sup>st</sup> January 2007 to 31<sup>st</sup> march 2008)

Due date of report: Month 16  
Actual submission date: Month 16

Start date of project: 01/01/2007

Duration: 15 months

Organisation name of lead contractor for this report : SIREHNA

Author of the document: J-P Borleteau + contributions of all partners

**Project co-funded by the European Commission within the 6<sup>th</sup> Framework Programme (2002-2006)**

**Revisions:**

<b>Index</b>	<b>Date</b>	<b>Authors</b>	<b>Reviewers</b>	<b>Subject</b>
A	30.04.08	JPB (SIR) + contributions of partners	IP (OSEO)	

## CONTENTS

<b>EXECUTIVE SUMMARY</b> .....	<b>4</b>
<b>1. PROJECT OBJECTIVES AND MAJOR ACHIEVEMENTS</b> .....	<b>6</b>
1.1 OVERVIEW OF GENERAL PROJECT OBJECTIVES.....	6
1.1.1 Introduction.....	6
1.1.2 Background.....	7
1.1.3 General objectives.....	10
1.2 SUMMARY OF THE ACTIVITIES.....	12
<b>2. SUPPORT ACTIVITIES</b> .....	<b>14</b>
2.1 WP1.....	14
2.1.1 OSEO.....	15
2.1.2 SIREHNA.....	16
2.1.3 IFTR PAS.....	16
2.1.4 VDI/VDE.....	17
2.1.5 BALANCE.....	17
2.1.6 CFA.....	17
2.1.7 SENTER NOVEM.....	18
2.1.8 APRE.....	18
2.1.9 ENPC/RST.....	20
2.1.10 CIT.....	20
2.1.11 CETRA.....	20
2.1.12 Synthesis of the results.....	20
2.2 WP2.....	21
2.2.1 OSEO.....	21
2.2.2 SIREHNA.....	22
2.2.3 IFTR PAS.....	22
2.2.4 VDI/VDE.....	23
2.2.5 BALANCE.....	25
2.2.6 CFA.....	25
2.2.7 SENTER NOVEM.....	26
2.2.8 APRE.....	26
2.2.9 ENPC/RST.....	26
2.2.10 CIT.....	26
2.2.11 CETRA.....	27
2.2.12 Synthesis of the results.....	27
2.3 WP3.....	29
2.3.1 OSEO.....	30
2.3.2 SIREHNA.....	30
2.3.3 IFTR PAS.....	32
2.3.4 VDI/VDE.....	32
2.3.5 BALANCE.....	32
2.3.6 CFA.....	32
2.3.7 SENTER NOVEM.....	33
2.3.8 APRE.....	33
2.3.9 ENPC/RST.....	33
2.3.10 CIT.....	33
2.3.11 CETRA.....	33
2.3.12 Synthesis of the results.....	33
2.4 WP4.....	35

2.4.1	OSEO .....	35
2.4.2	SIREHNA .....	36
2.4.3	IFTR PAS.....	37
2.4.4	VDI/VDE .....	37
2.4.5	BALANCE.....	37
2.4.6	CFA .....	37
2.4.7	SENER NOVEM.....	37
2.4.8	APRE .....	38
2.4.9	ENPC/RST .....	38
2.4.10	CIT.....	38
2.4.11	CETRA .....	39
2.4.12	Synthesis of the results.....	39
<b>3.</b>	<b>MANAGEMENT ACTIVITIES .....</b>	<b>41</b>
3.1	WP5.....	41
3.1.1	OSEO .....	41
3.1.2	SIREHNA .....	41
3.1.3	IFTR PAS.....	42
3.2	CONTRACTORS .....	42
<b>ANNEX:</b>	<b>PLAN FOR USING AND DISSEMINATING THE KNOWLEDGE.....</b>	<b>48</b>

## EXECUTIVE SUMMARY

The project EURO-TRANS\_Days has realised two European workshops in Warsaw (PL) on 17-18 October 2008 and in Madrid (SP) on 27-28 March 2008, in order to encourage, facilitate and enhance cooperation between SMEs of Surface Transport (road, rail, waterborne and intermodality), and major European RD players and Industrial Stakeholders of the European Research Area.

The preparation and realization of those two events was carried out with the active support of an advisory group comprising the European Technology Platforms (WATERBORNE, ERRAC, ERTRAC, EIRAG), and professional associations (EARPA, CLEPA, UNIFE, EUCAR, COREDES, EMEC).

Both events were focused on the preparation of the second call SST of FP7 programme (FP7-SST-2008-RTD-1) to help SMEs to participate in proposals.

The project was developed in 4 Work Packages in support activities:

- WP1: preparation of the two events
- WP2: realization of the event in Warsaw
- WP3: realization of the event in Madrid
- WP4: coaching and post-event actions

Both events provided plenary and parallel sessions (Polish and Spanish VIPs, strategic agendas of European technology platforms, successful SMEs, topics of the 2<sup>nd</sup> call) and workshops (open floor for presentations of ideas of project, SME competencies, ...) with more than 80 presentations in total for the two events. In Warsaw event 100 one to one meetings have been organised.

The two events gave opportunities to SMEs and other participants to obtain coaching services from the ETD partners. The coaching services have concerned more participants in Warsaw event, than in Madrid because the number of participants and the number project presentations/discussions were more important in the Polish event. This was carried out in different ways by each partner:

- Informal contacts and participation in 'one to one meeting' during the events
- Open discussions and project ideas presentations during the events
- Pre- and post-event contacts

After each event, the debriefing meetings pointed out that the participation of SMEs was indeed quite low (about 15%), and also the participation of Poland in Warsaw and Spain in Madrid was more than 50%. However the contacts with SMEs were very fruitful for developing ideas of proposals and providing advices to SMEs about FP7 opportunities.

ETD partners agreed that it was difficult to convince the SMEs to travel abroad for European Business events as proposed by ETD project. It was then agreed that for future actions, another way should be found. For instance, the organisation of awareness meetings at national level through the network of professional associations and local business centres seems to be a more appropriate to approach efficiently the SMEs, then the important work of ETD partners would be to provide relay and networking at European level: creating 'market place' of project opportunities, project ideas, SME's competencies, .... In that way, the ETD partners should then have a well established knowledge of the projects in preparation and contacts with key stakeholders leading European projects. Therefore, the active participation of key R&D leaders is recommended, as well as industry leaders (major industries of surface transport,

subcontractors of rank n°1) who will attract the interest of SMEs to attend local awareness meetings, and to liaise SME's own business to European RTD opportunities.

## 1. PROJECT OBJECTIVES AND MAJOR ACHIEVEMENTS

### 1.1 Overview of general project objectives

#### 1.1.1 Introduction

SMEs are major actors in technology development and innovation, but are too fragmented. Very few of them can reasonably claim to address directly R&D challenges which are becoming increasingly complex and often require an interdisciplinarity critical mass.

The EURO-TRANS\_Days is to encourage, facilitate and enhance cooperation between SMEs of Surface Transport (road, rail, waterborne and intermodality), and major European RD players and Industrial Stakeholders of the European Research Area.

EURO-TRANS\_Days is a follow-up of EURO-TRANS project and it aims at:

- increasing the integration of SMEs in European R&D projects of the 7<sup>th</sup> Framework Programme
- initiating new European partnerships (FP7, Eureka/Era-net, bi- or tri-national projects)
- increasing technology transfer and synergies between SMEs (cooperation agreements such as sharing and combining knowledge and know-how)
- increase links with the Transport Technology Platforms ERRAC, ERTRAC, WATERBORNE

The above objectives were achieved through the realization of:

- TWO INTERNATIONAL WORKSHOPS in MADRID (SP) and WARSAW (PL). Each of them will include presentations of Technology Platforms ERRAC, ERTRAC, WATERBORNE (strategic research agenda, themes of future FP7 projects), sessions (thematic/sectorial workshops; horizontal workshops on consortium agreement, IPR), one to one confidential meetings, coaching appointments. 200-300 participants per event are expected from all 25 EU members, candidate countries, associate countries and third countries.
- coaching services for SMEs to assist them in finding partners, identifying opportunities to participate in new projects, initiating projects from their own ideas, identification of SME's expertise, preparation of proposal.

EURO-TRANS website was used as support for organisation and promotion of the events, and the registration and coaching.

At the end of the project, all the results have been analysed and recommendations were delivered for future actions to reinforce SME networking process initiated by EURO-TRANS\_Days.

An advisory group was established with top-level advisers from the Technology Platforms (ERRAC, ERTRAC, WATERBORNE) and professional associations such as EARPA, EUCAR, CLEPA, UNIFE,

COREDES. This group provided complementary recommendations during the preparation of the events, in relation to the needs of major R&D players and Industrials Stakeholders.

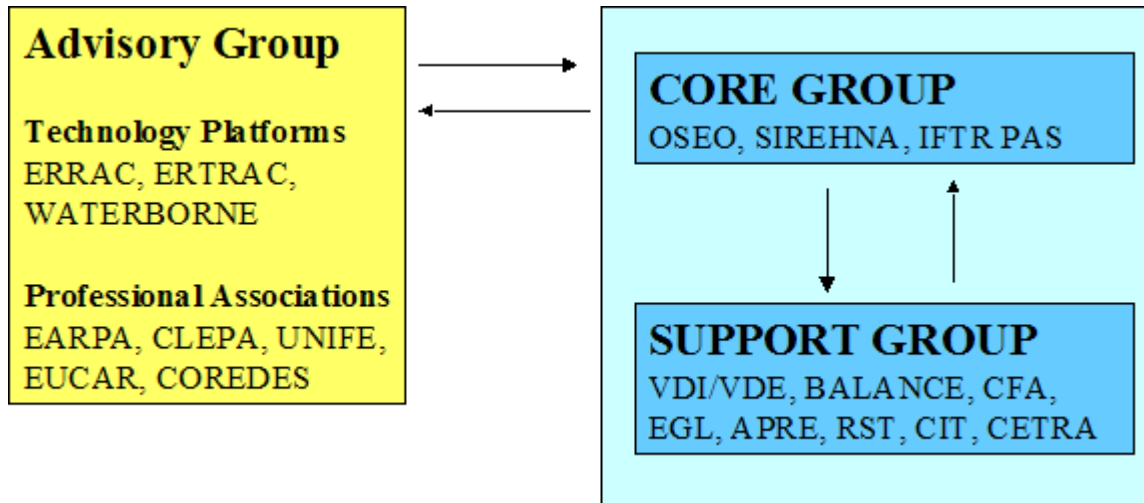

## 1.1.2 Background

### 1.1.2.1 The role of SMEs in European Research Area in surface transport sector

In the transport sector, the trend for SMEs is characterised by a need to develop higher value, through R&D and Innovation, and more likely in partnership than in ‘classical’ subcontractor relationships. Such partnerships have been already initiated through FP5 and FP6 European projects (IP, STREP, NoE, Cooperative and Collective projects).

The EURO-TRANS\_Days project has contributed to the reinforcement of the value chain by helping SMEs in positioning themselves as valuable partners.

Indeed, the advantages of SMEs in collaborative R&D projects are based on the one hand on the SMEs’ ability to react swiftly to new circumstances and to the customers’ requirements due to short internal hierarchies. On the other hand their range of activities is limited due to restricted resources of finance and personnel and they are hardly familiar with long term planning processes which are necessary to ensure the success of an R&D project, particularly of an Integrated Project.

Involving SMEs into a large European collaborative R&D project opens up the benefit from their advantages by assigning to them clearly defined limited tasks. SMEs can contribute to the success of the projects in the following ways:

- They provide special know-how and technological solutions (not only in niche areas).
- They exploit results from the projects beyond large scale applications.
- They provide customised solutions, for instance in the area of measurement techniques and equipments.
- They are able to contribute also to dissemination activities.
- They can be partners of demonstration activities in the research projects.

In this context, the EURO-TRANS\_Days project is aiming at reinforcing “globally” the role of SMEs in the transport value chain and facilitating the future participation of SMEs in FP7 projects in Surface Transport sectors (automotive, railways, waterborne, intermodality), in the continuity of previous SSA projects focused on Surface Transport (ETISMAR, EURO-TRANS, HUNPOL-TRANS, AutoINFP7, TranSMEs).

#### **1.1.2.2 Reasons for supporting SMEs**

SMEs are valuable partners to participate in European R&D projects and NoEs with a benefit for the projects. At the same time, the SMEs will improve their skills and possibilities to face future R&D and market challenges.

But, on the other hand, a principal barrier to such merging opportunities at European level is the cultural gap between SME’s usual way of working, often at national level, and the requirements of the European Research Area to carry out restructuration and rationalisation of ressources.

In fact, in the medium term (3-7 years), there is a big gain for the entire value chain of Transport to be more reactive to market needs by reinforcing partnership and networking of SMEs at European level, together with the major players of Surface Transport, particularly through the support of the Technology Platforms (ERRAC, ERTRAC, WATERBORNE, ...), as well as professional associations such as EARPA, EUCAR, CLEPA, UNIFE, COREDES, ...

Therefore, this networking process for SMEs has to be launched at the earliest time, in the beginning of future FP7, to help SMEs to initiate combination and merging their competencies to produce R&D results, with optimised competencies and expertise. The two workshops were held for the preparation of the second call of FP7 (Transport theme) open on December 2007 and closed on 7<sup>th</sup> may 2008 of 2008, to give the SMEs the possibility to participate in projects that were under preparation by industrial players.

Moreover, based on the experience of the actions conducted in previous specific support actions dedicated to SMEs (ETISMAR, EURO-TRANS, HUNPOL-TRANS, SURF-TRANS,...), this project has proposed coaching services for SMEs.

The benefits of attending the workshops for the SMEs are:

- Dedicated information on FP7
- Direct access to opportunities for participation in FP7 projects
- Opportunities to initiate projects
- Meetings with SMEs and industrial players to explore business opportunities
- Access to coaching services from a group of experienced NCPs

### 1.1.2.3 Aspects of SME networking

Due to the mentioned reasons, the objective of the project EURO-TRANS\_Days is to promote and facilitate the participation of SMEs in the 7<sup>th</sup> Framework Programme and especially towards the main types of projects of the Specific Programmes “COOPERATION” (R&D collaborative projects) and “CAPACITIES” (research for SMEs, research for SME associations).

Therefore, the project has started to initiate and develop:

- the build-up of structures (address book, information, communication structures, etc.),
- the matching of competencies of SMEs
- the coaching services for SMEs,
- the direct networking between SMEs thanks to one-to-one confidential meetings during the events.

The EURO-TRANS\_Days project has addressed its activities not only to member state SMEs but also to SMEs in the Union’s associate countries, possibly stimulating international cooperation with top-level organisations.

### 1.1.2.4 Aim

The strategic objective of EURO-TRANS\_Days is to encourage, facilitate and enhance the partnerships and cooperations of the Surface Transport (road, rail, waterborne and intermodality) SMEs of European Research-Area which are motivated to increase their European Strategy (reinforced RD business and capabilities, integration in European networks and projects), and particularly to better prepare themselves to the future FP7 opportunities.

The project addresses SMEs involved in the Surface Transport Area (road, rail, waterborne, intermodality). It is mainly focused on an increase and enhancement of R&D European Strategy of SMEs in the framework of European Research Area, including:

- R&D and Innovation capabilities/business reinforced by partnerships and alliances,
- technological and business intelligence,
- integration in european R&D projects and networks in the future 7<sup>th</sup> Framework Programme,
- synergies between different transport sectors (with transfer of horizontal technologies provided by specialised SMEs)
- increase links with the Transport Technology Platforms ERRAC, ERTRAC, WATERBORNE

The project is acting as a catalyst for bringing SMEs closer to the industrial and scientific key actors of the surface transport R&D and providing the community with comprehensive mapping of SMEs expertise.

To achieve these goals, EURO-TRANS\_Days will organise SME's workshops, based on a structure similar to the successful CRONET\_Days of April 2005 (120 participants, 500 one to one meetings), and complemented by coaching services for SMEs.

### 1.1.3 General objectives

#### 1.1.3.1 Operational Objectives of EURO-TRANS\_Days

The objective of the project EURO-TRANS\_Days is to facilitate and promote, in the area of Surface Transport industry, the close cooperation between SMEs, as service and technology providers, to all instruments of the 7<sup>th</sup> Framework Programme.

This goal was achieved by designing and providing TWO INTERNATIONAL WORKSHOPS in WARSAW (PL) and MADRID (SP) addressing to European SMEs dealing with Surface Transport sectors.

These meeting days aimed at:

- enhancing the creation of R&D and Innovation projects in the ERA
- increasing the integration of SMEs in European R&D projects and networks of the future 7<sup>th</sup> Framework Programme through the crucial role of the Technology Platforms (ERRAC, ERTRAC, WATERBORNE, and possibly other ones )
- initiating european partnerships between SMEs (FP7 Integrated Projects and Network of Excellence, Eureka, bi- or tri-national projects, as well as within the CIP objectives)
- increasing technology transfer and synergies inter-SME cooperation agreements such as sharing and combining knowledge and know-how, joint investments in common technologies and services, ...)
- networking on common R&D and Innovation areas by enabling cross-fertilisation of ideas and capabilities between the different surface transport modes.

Furthermore, the above objectives were achieved with the organization of coaching services for SMEs. These services were carried out before, during and after the two workshops.

Together with the two events, these objectives were achieved by coaching services for SMEs to help them to find partners, identify opportunities to enter in new projects, develop projects from own ideas of SMEs, identify of SME's competencies, prepare of proposal.

The EURO-TRANS\_Days services provided to the SMEs were mainly a help to :

- provide information about all possibilities to participate in future FP7 and relations to the main themes the specific programmes of Surface Transport ("targeted" presentations during the 1<sup>st</sup> day of the workshops);

- solve issues addressing horizontal subjects (consortium agreement, IPR, negotiation with the project leaders) and vertical aspects (workshops on networking and competence matching for selected projects or R&D needs);(specialised sessions on 2<sup>nd</sup> day of the workshops)
- organise brokerage event with “one to one confidential” short meetings between SMEs, and/or major industrial players (two sessions during the two afternoons of the workshops)
- provide services in coaching for SMEs (during the two afternoons of the workshops)
- organise relevant groupings of SMEs in order to participate in the future FP7 projects in preparation (outcome of the workshops)
- initiate the development of project ideas that have already shown to be of interest to some SMEs and supported by a FP7 work programme or call text
- to facilitate cross-fertilization experience between SMEs from the 25 Member States and the SMEs from new MS and associated Countries
- to organise relevant linking of SMEs with other dedicated European Networks and Initiatives (Eureka, Era-net, structural funds, ....)
- a help desk will be set up through Euro Trans website (subsequently to propose coaching services if SMEs are interested)

The workshops were organised based on the following methodology:

- Plenary sessions with presentations of Technology Platforms ERRAC, ERTRAC, WATERBORNE (strategic research agenda, themes of FP7 projects), major R&D players and success stories of SMEs. This presentations aim at:
  - o providing examples of projects,
  - o presenting opportunities for SMEs to participate in R&D projects,
  - o presenting themes of R&D of FP7 calls,
  - o presenting and explaining specific research programs for SMEs.
- Workshops (targeted on thematic/sectorial projects, or focused on transversal needs such as coaching sessions, consortium agreements and IPR) for developing ideas of innovation and collaborations. Scheduling based on answers to questionnaire filled at registration of SMEs.
- Brokerage event and one to one confidential meetings to make first contacts and create opportunities of projects and collaborations. Scheduling based on answers to questionnaire filled at registration of SMEs.
- Individual coaching appointments for SMEs

During the full period of the project a follow up of the SMEs was carried out:

- 1) Announcement and promotion of the two events and coaching services,
- 2) At registration : a questionnaire was filled by the participants before the event in order to map profiles, specific skills and themes of interest of SMEs and RD players,
- 3) During the event, the participants were asked to fill in an evaluation questionnaire (qualitative and quantitative evaluation, number of business appointments, planned follow up appointments and meetings for the SMEs),
- 4) Two weeks after the event a follow up questionnaire were addressed, especially to the SMEs in order to evaluate progress on their business contacts, difficulties encountered, needed support. Furthermore for those SMEs who are interested continuation in coaching was proposed.

## 1.2 Summary of the activities

<b>WP1</b>	<b>Preparation of the two events</b>
<p>The specification of the two events were established and were then followed by all necessary actions to prepare the events: objectives of the events, agenda of the two days of each event, identifying speakers, organisation of one to one meetings, pre- and post-event questionnaires, communication strategy for announcement to public and SMEs (websites, e-mailings, announcements in workshops, direct contacts), implementation on EURO-TRANS website, local organisation of the venues.</p>	
<b>WP2</b>	<b>Realisation of the event in Warsaw</b>
<p>The EURO-TRANS_Days conference in Warsaw on 17 and 18 October 2007 was focused on:</p> <ul style="list-style-type: none"> <li>- perspectives of cooperation with Polish industrial key players;</li> <li>- topics and research areas of the second call for proposals under the 'Sustainable Surface Transport' (SST) thematic area of the Seventh Framework Programme (FP7);</li> <li>- parallel road, rail, maritime and intermodal sessions;</li> <li>- research agendas of the European Technology Platforms, focusing on the needs for SMEs;</li> <li>- project proposals for the second FP7-SST call;</li> <li>- project management and coordination issues</li> <li>- one to one meetings</li> </ul> <p>The event was attended by 201 participants (including 119 from Poland), with more than 50 presentations (plenary, parallel sessions, proposals, open floor for project ideas, ...), with 96 one to one meetings between the participants.</p>	
<b>WP3</b>	<b>Realisation of the event in Madrid</b>
<p>The second event was initially prepared to be organised in Paris, but it was finally organised in Madrid. The EURO-TRANS_Days conference in Madrid on 27 and 28 March 2008 was focused on:</p> <ul style="list-style-type: none"> <li>- topics and research areas of the second call for proposals under the 'Sustainable Surface Transport' (SST) thematic area of the Seventh Framework Programme (FP7);</li> <li>- improving proposals (panel discussions)</li> <li>- Successful SME participations (presentations in round table)</li> <li>- Other FP7 research opportunities for SMEs (capacities, CIP enterprise, Eureka EUROSTARS)</li> <li>- research agendas of the European Technology Platforms, focusing on the needs for SMEs;</li> <li>- project ideas of SMEs for the second FP7-SST call (rail, road, waterborne)</li> </ul> <p>The event was attended by 100 participants with 30 presentations (plenary, parallel sessions, proposals, open floor for project ideas, ...).</p>	
<b>WP4</b>	<b>Coaching and post event actions</b>
<p>Debriefing meetings between the partners were carried out at the end of the second day of each event, in order to debate and summarise the main conclusions with respect to the target of the project and the recommendations for future events. It was completed by short reporting provided by the partners, afterwards. Results of post-event questionnaires showed strong interest of the participants in such events (information which is provided particularly through EURO-TRANS website means, opportunity to encounter experts, possibly to find out opportunities to join a project in preparation, ...). However, the conclusion of effective SMEs participations in FP7 projects is in reality low, even the establishment of the first contacts of SMEs with projects in preparation is low. A feedback report was sent to participants 'deliverable D4-1) and a final report (deliverable D4.2) was produced to conclude on the results of the project and recommendations for future actions.</p>	
<b>WP5</b>	<b>Management</b>
<p>Several project meetings have been called and organised by the Project Manager to set up the preparation and the coordination of the work to realise the two events in Warsaw and Madrid. The Project Manager was operating the project on a day-to-day basis in close relation with the EU officer in</p>	

charge of the project, and the project partners as well as the advisory group. A final report (D5.1) was produced for summarising the project's activities and assessing its impact. A second report (D5.2) was produced for summarising the dissemination and exploitation activities.

## 2. SUPPORT ACTIVITIES

### 2.1 WP1

WP title	Preparation of the two events
WP objectives	The objective of this workpackage is to design/specify the two international workshops aiming at increasing SME participation in FP7 projects, to be organised in Madrid and Warsaw: setting up a technical/scientific organisation committee, agenda of the meeting, communication strategy, overall organisation of the venues for WP2 and WP3, design pre-event and post-event questionnaires addressed to SMEs, assemble a database of targeted SMEs which are active in the field of surface transport and would be interested in participation in the future FP7.

An advisory group was established with top-level advisers from the Technology Platforms (ERRAC, ERTRAC, WATERBORNE) and professional associations such as EARPA, EUCAR, CLEPA, UNIFE, COREDES. This group will provide complementary recommendations during the preparation of the events, in relation to the needs of major R&D players and Industrial Stakeholders.

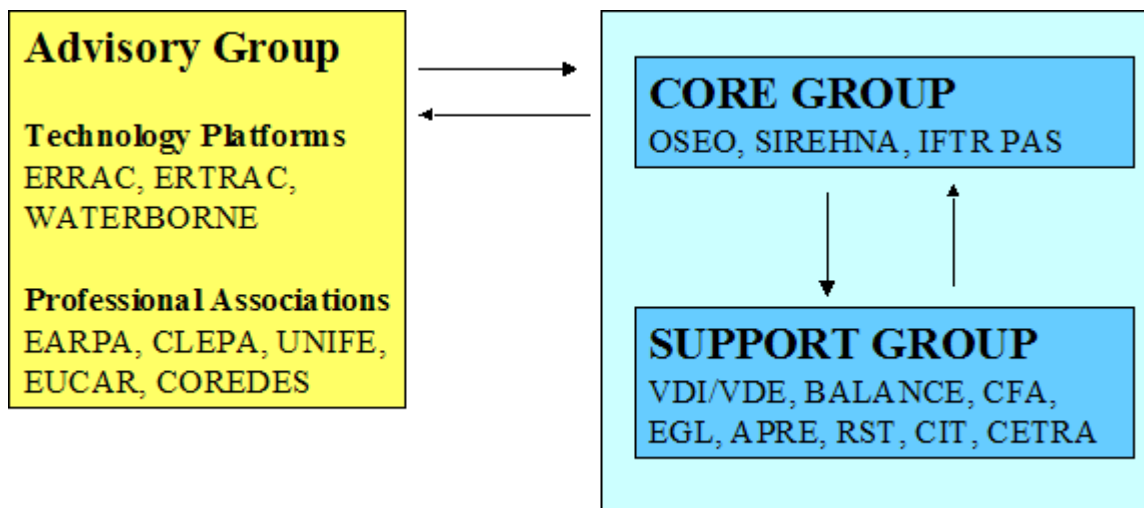

### 2.1.1 OSEO

OSEO prepared, organised and chaired the meetings with the help of Sirehna during the whole project duration (kick-off meeting, steering committee meetings, final meetings). Furthermore OSEO coordinated the day to day work of the project in view of the two international workshops through :

regular exchanges of emails, phone calls and teleconferences with the partners

- Drafting of the agenda's and the reports of the meetings
- Appealing to the Advisory Group for support and advice
- Identification/invitation of speakers for the Warsaw workshop
- Realization of the pre-announcement of the Warsaw workshop
- Design of the structure of the two events
- Providing of input for the implementation of additional functions on the EURO-TRANS web site in the frame of Task 1.5
- Preparation of the registration procedure and contribution to the adaptation of the registration tool of VDI/VDE to the specific requirements of the project
- Defining of the communication strategy and preparation of promotion tools for the consortium (text for mailings)
- Defining of the needs for the implementation of the tool for the one-to-one meetings implemented by VDI/VDE.
- Preparation of the Warsaw programme with P3 and the consortium
- Preparation of the practical sessions during the Warsaw event with P7.
- Preparation and organisation of the parallel sessions on road, rail, maritime and intermodal with the ETPs in each sector, identification and briefing of moderators and speakers
- Realisation of the final brochure of the Warsaw event

OSEO organised and attended the following meetings :

- Kick-off meeting held on January 16<sup>th</sup> 2007 in Brussels
- Progress meeting held on February 15<sup>th</sup> 2007 in Brussels partly dedicated to the follow-up of the Euro-Trans\_Days contract
- Conference of the International conference European Transport in FP7 organised by Polish NCP Transport from 1<sup>st</sup> of 2<sup>nd</sup> March 2007. Meeting with Z. Turek and presentation of the 1<sup>st</sup> international EURO-TRANS\_Days workshop in Warsaw from 17<sup>th</sup> to 18<sup>th</sup> October 2007.
- EARPA mobility workshop organised by EARPA in Brussels on March 5<sup>th</sup> 2007. Identification of speakers for the Warsaw workshop.
- Meetings with the European Technology Platforms on 27<sup>th</sup> March 2007 in Brussels
- Steering Committee Meeting held on July 12<sup>th</sup> 2007 in Brussels
- Steering Committee Meeting held on October 4<sup>th</sup> 2007 in Brussels
- Final Meeting held on March 28<sup>th</sup>, 2008 in Madrid

On a national level OSEO ensured a wide promotion of the workshops and carried out dissemination activities in the frame of several national events in transport. Promotion efforts were mainly addressed to SMEs but also other important actions in the field of industry and R&D dealing with Surface Transport.

#### **Mailing :**

over 1000 e-mails addressing to SMES, RTOs, professional organisations, industry  
over 100 invitations to National technology platforms and pôles de compétitivité  
over 300 telephone calls addressing to SMEs and pôles de compétitivité

**Information on the internet pages :**

<http://Cordis.europa.eu>

[www.eurosfaire.prd.fr](http://www.eurosfaire.prd.fr) (French service for access to information on Research in Europe)

[www.oseo.fr](http://www.oseo.fr)

emobility platform

websites of professional transport organisations, FIEV, ECTRI,  
websites of the French pôles de compétitivité in the field of transport  
national websites of the European Technology Platform, ertrac, waterborne, errac, eirac  
distribution of flyers at ERA-net conference of september 2007

**Oral presentations during**

National promotion meetings for FP7 transport surface

Conférence SIFER Lille organised by the cluster i-Trans

Meetings organised by the French SME NCP and transport NCP

**2.1.2 SIREHNA**

Contribution to tasks:

(1-1) specification of the two events

(1-2) announcement to SMEs and public

(1-3) identification of speakers

(1-4) organisation of one to one meetings

In this work package the contribution of SIREHNA was:

- To attend several WP1 preparation meetings in Brussels (January, July, and October 2007), concerning both events to be organised in Warsaw, and Paris/Madrid.
- To deliver own experience and know-how from previous project CRONET-DAYS (that was organised by SIREHNA) for specification and organisation of scientific and technical programme of the two events (overall agenda, approach of speakers, concept of one to one meetings, concept of coaching sessions)
- To contribute to establish agenda of Warsaw and Madrid events and to contact speakers for the final programmes.
- To create the agenda of Paris event, which was then revised as the second event was finally organised in Madrid
- To create pre- and post-event questionnaires for the two events for preparation of work in WP4.
- To disseminate relevant information (announcements and registration forms) about the events through 'own SIREHNA' e-mailings (more than 1500 contacts on own database in France and Europe) and own website publication.

**2.1.3 IFTR PAS**

Participated actively in numerous meetings dedicated to the organization of conferences in Warsaw. The meetings were organized to work out agenda, prepare the conference leaflet, how the project webpage should look like, whom to invite to the conferences as regards main speakers and other issues like how big the conference should be and so on. During the meetings all responsible project partners (IFTR PAS including) also presented their WP results. In the later stage IFTR PAS also informed the consortium on

the Warsaw conference progress e.g. how many rooms were rented, how one-to-one sessions was going to be organized, other details like ppt projectors, meals, number of stands for project presentations, what leaflets to be distributed during the conference etc. IFTR PAS also made some contribution to the deliverable D1.2.

However the main work of the work-package was carried out at our offices. The meetings were organized to summarize work done before them and to define tasks to be done in the future. They speeded up the work in the WP and stimulated the consortium to more effective work.

Much effort in the work-package was put at the identification of all events taking place all over Europe in order to choose the right date for the conference in Warsaw. It was crucial to the success of the conference. The conference was dedicated to the second call for surface transport calls to be published December 2007.

#### **2.1.4 VDI/VDE**

No input

#### **2.1.5 BALANCE**

BALance was the leader of task 1.5, which had the following objectives:

Task 1.5 : Euro-Trans Internet Site

According to the needs of task 1.1, this task will implement additional functions to the Euro-Trans Internet site which will support the organisation and promotion of the two workshops. It will include functions to register SMEs for the brokerage events, matching of SME and expert profiles, registrations of participants, publication of presentations etc. Furthermore, it will maintain and update the site during the project duration.

As described within D1.1 BALance implemented the Euro-Trans-Days internet site according the requirements of the responsible event organisers. The site promotes the two events in Warsaw and in Madrid. The site has been regularly updated reflecting the organisational progress of the events:

- Pre-announcement of the event
- Draft and Final event agenda
- Travel and hotel information
- Upload of the speakers presentations

#### **2.1.6 CFA**

Participated in meetings, in Brussels, and email and telephone discussions concerned with Agendas for Warsaw and Paris events.

Dissemination of events, as follows:

Publication as follows:

[www.fp7uk.org](http://www.fp7uk.org) - the website of the UK National Contact Point

Mailing to all SMEs and organisations registering on the FP7UK website, expressing an interest in Surface Transport.

Information emailed to all UK networks with an interest in Surface Transport, as follows:

- ⇒ Shipbuilders & Shiprepairers Association
- ⇒ Society of Maritime Industries
- ⇒ British Marine Federation
- ⇒ Railways Industry Association
- ⇒ Foresight Vehicle
- ⇒ Low Carbon Vehicle Partnership
- ⇒ CENEX
- ⇒ Low Carbon & Fuel Cell Knowledge Transfer Network

Each of the above then notified their own Membership and/or provided information on their websites.

Information emailed to UK “Regional Development Agencies” and “Dissolved Administration” for dissemination of information.

Oral presentations at FP7 Information Days and workshops.

### **2.1.7 SENTER NOVEM**

SenterNovem participated actively in the preparation of the Warsaw and Madrid events.

For the preparation of the Warsaw event several meetings were attended in Brussels. SenterNovem assisted the coordinator in contacting speakers from the Netherlands. SenterNovem was also responsible for the planning of the session of the Expressions of Interest. In total 19 EoIs were presented in Warsaw. The Warsaw event was announced in the Netherlands by several mailshots to the SenterNovem transport contact database with over 3000 entries. The announcement was also included on the EGL website and in the monthly newsletter ‘R&D in Europe’.

For the preparation of the Madrid event, SenterNovem took active part in the email discussions between the consortium partners to define the approach and the agenda. A presentation was prepared on several SME-experiences from the Netherlands.

The Madrid event was announced in the Netherlands by several mailshots to the SenterNovem transport contact database with over 3000 entries. The announcement was also included on the EGL website and in the monthly newsletter ‘R&D in Europe’.

### **2.1.8 APRE**

Since the project beginning, APRE took active part in providing inputs to the major initiatives assessing the specification of the two international workshops and their overall structure:

- Definition of the agenda’s requirements, standard content and its adaptation to the project’s circumstances;
- Communication strategy;

- Identification/Invitation of suitable speakers;
- Exchange of information with the EU Technology Platform and EU industrial stakeholders;
- Arrangement of coaching and parallel sessions;
- Contribution to the project web-site customization;
- Preparation of the registration procedure, mainly throughout focused inputs on the “Profile registration form” template;
- Managing logistic issues.

To this end, several Meetings and Conference Calls were organised. APRE attended the following:

- Kick-off meeting (Dr. Sabrina Bozzoli) held on January 16<sup>th</sup> 2007, in Brussels. During the meeting a brief presentation of APRE and its activities in the project was provided.
- Conference call held on April 20<sup>th</sup> 2007.
- Steering Committee Meeting (Dr. Katia Insogna) held on July 12<sup>th</sup>, 2007 in Brussels.
- Steering Committee Meeting (Dr. Sabrina Bozzoli) held on October 4<sup>th</sup>, 2007 in Brussels
- Final Meeting (Dr. Sabrina Bozzoli) held on March 28<sup>th</sup>, 2008 in Madrid.

The dissemination activities carried out by APRE ensured a wide promotion of the workshops and a good feedback in terms of participation at national level. They were mainly addressed to SMEs, together with other R&D stakeholders (Universities, Research Centres, Industrial Associations, etc...) dealing with surface transport research area.

1. Warsaw International Workshop (17<sup>th</sup>-18<sup>th</sup> October, 2007)

- o Project presentation and distribution of 50 copies of the workshop pre-announcement leaflet [National Info day on “Transport (including aeronautics) – first call for proposals”, held in Rome on March 26<sup>th</sup>, 2007]
- o Article on APRE Newsletter (number of May 2007)
- o Promotion on APRE’s website;
- o Mailing list to APRE’s database contacts (1943 entries)
- o Mailing list to TransMES project’s partners, asking to forward it to their national contacts (July 2007)
- o Article on LEONARDO R&D Newsletter (number of July 2007)
- o Article on web site [www.reloaderalia.it](http://www.reloaderalia.it) - REverse LOGistics And Development of Environmental Research
- o Mailing list reminder to APRE’s database contacts (1779 entries)

2. Madrid International Workshop (27<sup>th</sup> – 28<sup>th</sup> March 2008)

- o Project presentation and workshop promotion [“DAGOT project final conference”, held in Genoa on 17<sup>th</sup> January 2008; “GALILEO Info Day”, held in Rome on 22<sup>nd</sup> January 2008; “Transport (including aeronautics) Info Day. Results of the first call for proposals and second call’s content”]
- o Promotion on APRE’s website
- o Article on APRE Newsletter (number of January 2008)
- o Article on web site [www.reloaderalia.it](http://www.reloaderalia.it) - REverse LOGistics And Development of Environmental Research
- o Mailing list to APRE’s database contacts (1943 entries)
- o Mailing list reminder to APRE’s database contacts (1943 entries)

Finally APRE contributed to the finalisation of Deliverable 1.1.

### 2.1.9 ENPC/RST

#### 2.1.10 CIT

CIT at the beginning of the project updated the contacts the Spanish SME and other organisations on surface transport. In addition to the mails and distribution channels, direct contacts by mail and phone were primarily used

CIT assured the support and involvement of the Spanish Transport NCP (Mr. Jesús Monclús, from the the Centre for Development of Industrial Technology – CDTI, Ministry of Industry, Tourism and Trade), and also from the Spanish Ministry of Education where J B. Pérez Prat participated in national Surface Transport projects maritime and logistics proposal evaluations and projects follow-up.

On maritime transport CIT SL participated as consultant for the Spanish subcontractor (IZAR) of the 5FP INTERSHIP and used previous contacts as well as contacts trough the Spanish WATERBORNE mirror Thematic Platform and Spanish Foundation INNOVAMAR who was the representative of MARTEC

CIT through Juan B. Pérez Prat attended the following meetings

- Kick-off meeting held on January 16<sup>th</sup> 2007, in Brussels.
- Preparation meeting February 15 in Brussels.
- Organising a Spanish Warsaw Preparation meeting September 24<sup>th</sup> Madrid
- Preparation meeting October 4<sup>th</sup>, 2007 in Brussels
- Warsaw workshop evaluation meeting after the workshop 2007
- 4 Madrid workshop preparation meetings with CDTI in Madrid
- Hosting and organising the Final Meeting held on March 28<sup>th</sup>, 2008 in Madrid.

CIT made also two announcements and presentations of the EUROTRANS days project and workshop on CDTI Surface Transport and on the Madrid Polytechnic University Info days

#### 2.1.11 CETRA

Preparation of the two events

The objectives of this work package was to specify the two events (conference in Warsaw and workshop in Madrid), setting up a technical organization committee, agenda of the meeting, communication strategy overall organization of the venues for WP2 and WP3, design pre-event and post-event questionnaires addressed to SMEs, assemble a database of targeted SMEs which are active in the field of surface transport and would be interested in participation in the future FP7.

CETRA – participated on two meeting of the committee in Brussels for the event in Warsaw. The committee had decided of the agenda of the conference in Warsaw, overall organization of the venues for WP2 and questionnaire addressed to the SMEs.

#### 2.1.12 Synthesis of the results

The specification of the two events were established and were then followed by all necessary actions to prepare the events: validating the objectives of the events, establishing the agenda of the two days of each event, identifying speakers, organisation of one to one meetings, defining pre- and post-event

questionnaires, communication strategy for announcement to public and SMEs (websites, e-mailings, announcements in workshops, direct contacts), implementation on EURO-TRANS website, local organisation of the venues.

This WP provided the right support for the realisation of the two events, thanks to the complementarity of experience and expertise of the different partners for designing the agenda of the events, contacting key speakers, organising locally the events, providing active communication links and means (especially the NCP partners) for announcing the events towards SMEs of Surface Transport sector (also with complementarity of expertise between rail, road and sea domains), providing coaching services, organising one to one meetings, establishing the website for communication towards the public.

## 2.2 WP2

<b>WP title</b>	<b>Realization of the Warsaw event</b>
<b>WP objectives</b>	This work-package aimed to realise the two-days event in Warsaw in Oct. 2007

The EURO-TRANS\_Days conference in Warsaw was focused on:

- perspectives of cooperation with Polish industrial key players;
- topics and research areas of the second call for proposals under the 'Sustainable Surface Transport' (SST) thematic area of the Seventh Framework Programme (FP7);
- parallel road, rail, maritime and intermodal sessions;
- research agendas of the European Technology Platforms, focusing on the needs for SMEs;
- project proposals for the second FP7-SST call;
- project management and coordination issues.

All Eurotransday partners participated in the two-days event and supported:

- coaching services toward interested SMEs,
- matching of SME competencies on the basis of questionnaires,
- facilitating contacts between major players and SMEs.

During the conference participants could :

- present their project ideas for collaborative and transnational cooperation
- offer their technologies for industry or express their technology needs
- promote their organizations (e.g. using posters)
- present their successful projects
- participate in workshops focusing on project definition and consortium building
- meet project coordinators and experts

The conference was implemented according to the agenda described in D2.1.

More details on the conference can be found at D2.1

### 2.2.1 OSEO

OSEO (Ineke Petit and Robert Csukai) coordinated the First Euro-Trans Days International Workshop, held in Warsaw from 17<sup>th</sup> to 18<sup>th</sup> October 2007 with P3. OSEO contributed to its successful performance through the following activities

- Coordination of the overall event
- Short brief with all speakers of the parallel thematic sessions

Bilateral meetings with :

- Geoffry Goulley – Stratiforme Industries
- Claire Plantie-Niclause – ECTRI
- Christophe Pupier – Alma Consulting
- Yves Ravelard – Pôle I-trans
- Bruno Leporcq – Onera
- Xavier Apolinarsky – CEA
- Mauro Salvatore – INSEAN
- Tomislav Letnik – Univerz v Marboru
- Roberto Santolamazza – Treviso Tecnologia
- Janis Kokars – Latvija Juras Akademija
- Maite Alvarez – Robotiker Tecnalía
- Roland Frindik – Studiengesellschaft für den kombinierten Verkehr e.V.
- Marcin Foltynski – Instytut Logistyki i Magazynowania
- Ellen Naaykens – Buck Consultants International
- Vittorio Carta – Deutsche Bahn AG
- Giorgio Travaini – UNIFE
- Ken Wittamore – Triskel Consultants Ltd
- Juan Torres Arjona – ETSIT-UPM
- Andrzej Urbanik – Instytut Badawczy
- Danielle de Bruin – Connekt
- Patrick Person – Emec-Gican

### 2.2.2 SIREHNA

In this work package the contribution of SIREHNA was:

- To prepare and attend to the two days event in Warsaw on 17-18 October 2007
- To animate the practical session on ‘safety’ on the first day
- To chair the Maritime session on the second day
- To participate in one to one meetings on the two days: Innovar (Spain), Dublin Institute of technology (Ireland), Vilnius technical University (Estonia), Szczecin Ship Yard (Poland), INTA (Spain), Gdynia Maritime University (Poland), Gdansk University of technology (Poland), Robotiker Tecnalía (Poland), Autocomp (Poland)
- To attend the debriefing meeting in the afternoon of the second day.

### 2.2.3 IFTR PAS

Our activities were concentrated on:

- active support to the coordinator in establishing the agenda

- proposals of top class speakers for the plenary sessions,
- support to the implementation of pre-event and post-event questionnaires addressed to SMEs for organising one to one meetings, and for mapping SMEs competencies or proposals
- dissemination of announcements (mailing, and dissemination to international and professional websites
- support to identify moderators for the 4 parallel sessions of the second day
- identification to showcases of SMEs
- sending invitations
- looking for and talking with SMEs

What was made:

- over 5000 e-mails -addressed to SMEs , associations, industry, high schools
- over 300 invitations letter - addressing to SMEs , associations
- over 400 telephone calls - addressing to SMEs , industry, National Technology Platforms

information on the internet pages:

- [www.kpk.gov.pl](http://www.kpk.gov.pl)
- [www1.ukie.gov.pl](http://www1.ukie.gov.pl)
- [www.pim.org.pl](http://www.pim.org.pl)
- [www.logistyka.net.pl](http://www.logistyka.net.pl)
- [www.doktoranci.pw.edu.pl](http://www.doktoranci.pw.edu.pl)
- [www.tu.kielce.pl](http://www.tu.kielce.pl)
- [www.pptbib.pl](http://www.pptbib.pl)
- [www.e-petrol.pl](http://www.e-petrol.pl)
- [www.euro-trans.info](http://www.euro-trans.info)
- [www.eltis.org](http://www.eltis.org)
- [www.transport-era.net](http://www.transport-era.net)
- [www.cordis.europa.eu](http://www.cordis.europa.eu)
- on pages of Regional and Branch Contact Points
- on project pages (Hunpol-Trans, Auto-in )
- articles to “Granty Europejskie” (June, September, November –after conference)
- information for press
- organisation the Infoday - 11th September – participants were mainly from High Schools and Organizations
- participation in Conference for Young Scientists – promotion the Conference
- EoI action

Moreover IFTR PAS gave some presentations as well as chaired the main session of the conference.

## 2.2.4 VDI/VDE

### Promotion and Dissemination Warsaw conference:

- Event announcement in mstnews ([www.mstnews.de](http://www.mstnews.de))
- Event announcement in the German Automotive magazine from the Hanser Verlag
- Invitation sent to 85 small and medium sized Enterprises in Germany
- Invitation sent to 9 German transport associations
- Event announcement sent to 28 transport and logistic magazines in Germany
- Forwarding of information to the NCP in Switzerland (Dr. Randall) and NCP in Austria (Mr. Rohowetz)

## **One-to-One Meetings during the EURO-TRANS\_Days Warsaw, 17-18 October 2007**

The One to One Meetings during the EURO-TRANS\_Days in Warsaw aimed at bringing together potential partners from the fields of surface transport for common project proposals or for bilateral co-operations (technical collaborations, business co-operations, ...) during face-to-face, confidential meetings. In order to enhance the efficiency and the outputs of such meetings, a dedicated and structured organisation had been required on the model of the Brokerage Events organised in other European projects.

The principle is that each participant fills in a One to One profile prior to the event, notifying his main fields of activities and research topics, as well as describing his desired partners. All profiles are then compiled and available online. On this basis, the participants can request for One to One meetings with persons who inserted an interesting profile, still prior to the event.

For the Event in Warsaw, 100 participants to the conference were also registered for the One to One meetings and 27 One to One profiles had been published.

Almost 200 meetings requests had been received prior to the event leading to the arrangement (matching) of 160 One to One meetings (some meetings would have been requested from both sides or no common slots between both persons were found to arranged the meeting requested,...)

Shortly before the event participants are notified with their personal meetings schedule, giving them a time and location for each of their individual meetings during the event.

During the event, each One to One Meeting is consciously followed-up as it is always subject to last time changes, delays or cancelations.

During the 2 days of the EURO-TRANS\_Days, 100 One to One meetings, of 20 minutes each, took place in several dedicated rooms, involving more than 60 participants. The rate of transnational meetings was reflecting the remarkable international participation to the conference as 80% of all meetings were transnational.

A further follow-up operation, two months after the event, allows the organisers to get the actual state of the co-operations eventually initiated during the One to One meetings and to learn about collaborations reached with the help of the individual meetings.

The follow-up phase for the Warsaw event, which took place in December 2007, reported that 14 collaborations were still on-going and even that some were in deeper negotiation. In January 2008, 2 signed co-operation agreements issued from the EURO-Trans\_Days had been reported. These agreements, both between the regions of Flanders and of Catalonia, are collaboration in the field of Automotive / Road vehicles. The first one deals with the common development of a multi-hybrid vehicle as the second one concerns the implementation of a dual electrical motor system for truck transmission.

One to One Meetings – Factsheet:

### **Euro-Trans Days - One to One Meetings**

#### **Results**

Number of persons registered for the one to one meetings	100
External profiles processed	27
Number of meetings requests	196
Number of meetings cancelled prior to the event	22
Number of meetings matched	161
Number of meetings which couldn't be matched (no common slots, ...)	6
Number of meetings which took place	101
Number of transnational meetings which took place	81
Number of persons who had meetings	64
On-going collaboration after 2 Months	14
Collaborations reached	2
<b>Indicators</b>	
Persons who had meetings / registered for the meetings	64%
Meetings which took place / Meetings requests	52%
Meetings transnational / meetings took place	80%
Average number of meetings per person	3,2

### 2.2.5 BALANCE

BALance promoted the Warsaw event on their web site and forwarded the event announcement to selected business contacts. During the event BALance chaired a coaching session and provided advice to six project proposals under preparation.

### 2.2.6 CFA

Participation in Warsaw events, including acting as Chairman of a “rail” workshop

### 2.2.7 SENTER NOVEM

SenterNovem attended the Warsaw event on October 17 and 18 2007. SenterNovem took care of the arrangements around the sessions on the Expressions of Interest and chaired the session on road-transport related research.

### 2.2.8 APRE

APRE (Sabrina Bozzoli) participated to the First Euro-Trans Day International Workshop, held in Warsaw from 17<sup>th</sup> to 18<sup>th</sup> October 2007; it contributed to its successful performance, carrying out the following activities:

- Chairing, together with SenterNovem, the practical-coaching session on “intermodal transport. Each participant was given the opportunity to present its research idea and to discuss it with the experts and the other people attending the session;
- Chairing, together with EIRAC, the parallel session on “Comodality”. Participants to such session showed great interest towards the subjects discussed, also due to the high quality of speakers involved.
- Participating to several one-to-one meetings with those participants specifically interested on the call for proposals’ content and/or in legal and financial aspects dealing with FP7.

### 2.2.9 ENPC/RST

### 2.2.10 CIT

CIT (Juan B. Pérez Prat) as Spanish EUROTRANS partner, contributed to the Warsaw workshop with 34 attendants from Spain actively participating with EoIs, Posters and one-to-one meetings.

<b>WARSAW workshop</b>	<b>SPANISH</b>	<b>TOTAL</b>	<b>%</b>
Final attendants (non show-ups excluded)	29	<>180	<>16
Number of transnational one-to one meetings	43	76	59
Number of persons who had one-to-one meetings	15	62	24
Number of Eols	14 (10)	21	50%

Holding a dedicated meeting to the Eurotrans Days Workshop the 24 September at CDTI with presentations and a brainstorming for EoIs and Q&A Jesús Monclús made 3 massive mailings through his Surface Transport mailing lists.

The workshop promotion meeting was attended by Telefónica I+D, ITENE, Innovamar, AIMEN, INTA, ISDEFE, and the Polytechnic University of Madrid who held a special meeting later with the different Madrid Polytechnics (7) relevant to Surface Transport.

Mr M.A. Pesquera intermodal expert chaired the parallel EoI session.

Short EUROTRANS workshop announcement on the Spanish Surface Transport Call Info Day at CDTI, Madrid.

EUROTRANS Days and workshop presentation on the Madrid Polytechnic University forum Info Day

EUROTRANS workshop links on CDTI, Polytechnic National PTs and EU projects IPR and EUROALERT web pages.

Juan B Pérez Prat made in Warsaw two presentations (Two examples of successful Spanish SMEs on recent Integrated Projects)

Juan B. Pérez Prat contributed directly and indirectly to the EoIs: 14 EoI from Spain posted and 10 discussed more than half of the total in the workshop

Participation also on the workshop parallel sessions discussion.

Informal coaching to Spanish participants before, along and after the workshop.

Attending to the preparation meetings and contributing by email and phone along the phase of preparation.

Participation on the post-event review meeting

### 2.2.11 CETRA

Realization of the Warsaw event

The objective was organized the two days event in Warsaw (17-18.10.2007)

CETRA – participated on the conference in Warsaw and CETRA participated on one to one meetings.

### 2.2.12 Synthesis of the results

Some statistics

- **201 participants** (119 from Poland)
- **13 presentations** (during Main session)
- **15 proposals** for subjects from the Work Programme 2008 (during Practical Session )
- **21 presentations** (during Parallel Sessions)
- **19 presentations** ( during “Open floor for projects ideas”)
- **2 project meetings**
- **96 one to one meetings**

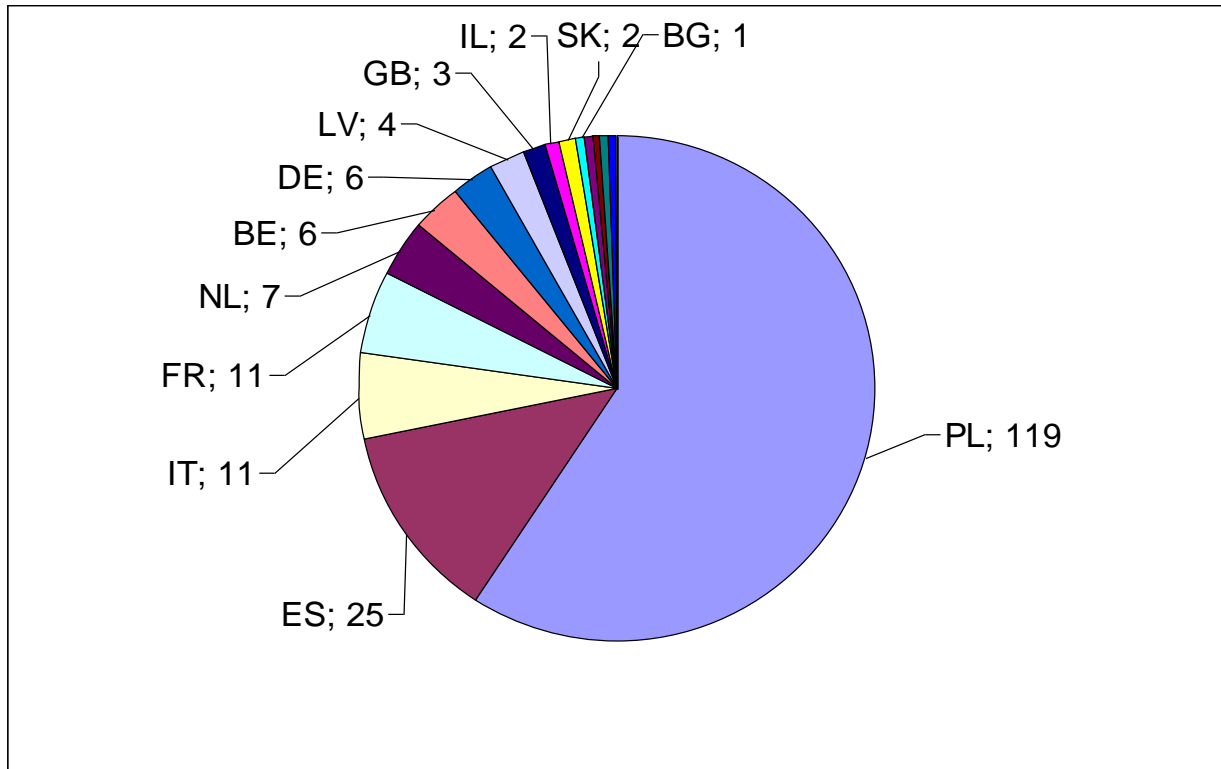

Country	Number of registered Participants	Number of Participants attending the conference
PL	129	119
ES	30	25
IT	21	11
FR	13	11
NL	12	7
BE	8	6
BG	6	1
DE	5	6
GB	4	3
AL	3	0
IL	2	2
LT	2	0
LV	3	4
PT	2	1
SK	2	2
AT	1	0
CH	1	0
IE	1	1
NG	1	0
RO	1	0
SI	1	1
UA	0	1
Sum	248	201

The statistics of Polish participants

<b>Entity</b>	<b>Number of registered Participants</b>
University	28
Firms	36
Institution	39
Associations and Organization	16
<b>Sum</b>	<b>119</b>

### 2.3 WP3

<b>WP title</b>	<b>Second Eurotrans days Worksoop Madrid</b>
<b>WP objectives</b>	<b>Complete the compliance of the EUROTRANS Days project objectives through a second and final workshop</b>

See Deliverable 3.1 by CIT SL with the following index

1. Rescue of the second EUROTRANS Days Workshop
2. Specification of the event
3. CDTI contribution
4. Consortium contacts and contribution
5. VIPs, Advisory Group, invited speakers
6. Industrial Associations and Technology Platforms
7. Administrations
8. Dissemination
9. Targets /v outcomes
10. Final Programme
11. Special presentations
12. Expressions of Interest
13. Posters

14. One to one meetings, and coaching
15. CDTI Internet link
16. Attendance lists, and graphs
17. Post event evaluation and feedback
18. Conclusions of the organizer
19. Summary of the final EUROTRANS Days project meeting

The list of attendants, presentations, EoIs and posters are available at this date at the CDTI www special EUROTRANS Days link, created end of February for dissemination, downloading and registration

### **2.3.1 OSEO**

No input

### **2.3.2 SIREHNA**

Contribution in tasks:

- (3-1) 1<sup>st</sup> day
- (3-2) 2<sup>nd</sup> day
- (3-3) Venue and local organisation

In this work package the contribution of SIREHNA was:

- To prepare the Paris event, under the leadership of OSEO: establishment of initial agenda at the end of October, and list of potential speakers. Then, SIREHNA took the leadership of WP3, as the two key persons of OSEO were ill for a long period. During this period SIREHNA employed one additional person for secretary tasks and day to day work of this preparation. After several contacts to potential speakers, the first announcement was launched by SIREHNA in mid of January 2008 (e-mailings, publication on partners web as well as on EURO-TRANS website. (see hereafter the document).

**EURO-TRANS\_Days PARIS 27-28 March 2008***2<sup>nd</sup> call of the 7<sup>th</sup> Framework Programme**European Business Days for R&D projects in Surface Transport***ROAD RAIL WATERBORNE INTERMODALITY**Objectives:

This two-days event is aiming at encouraging, facilitating and enhancing cooperation between SMEs and the major European R&D players and Industrial Stakeholders of Surface Transport for:

- R&D projects in the 2<sup>nd</sup> call of the 7<sup>th</sup> Framework Programme
- technology transfers and synergies between stakeholders (such as sharing and combining knowledge and know-how, joint investments in common technologies and services, ...)

Contents:

A/ Two morning sessions of conferences, workshops and round tables will give a vision of Research Agendas of Technology Platforms and large European R&D players, successful experiences of SMEs and R&D players in European projects related to Surface Transport of 7<sup>th</sup> Framework Programme. These sessions will provide information on short- and medium-term opportunities for the participation in R&D projects in the 2<sup>nd</sup> call and future EU calls.

B/ Both afternoons will be devoted to one-to-one confidential meetings. Lasting 15 minutes, these meetings will allow the participants to make first contact and discuss possible technical partnerships, technology transfers, business agreements, ... Each participant will be invited to fill a profile form (activities, expectations) before the event. A schedule of one-to-one meetings will be established for each participant.

C/ During the two-days event, rooms will be available for confidential meetings in small groups for working on proposals, and participants will have the possibility to promote their organization and their projects with posters.

R&D Themes: greening of surface transport, modal shift and decongesting transport corridors, urban mobility, safety and security, competitiveness

Target audience: SMEs, large companies, R&D players (research and technical centers), professional organizations

Speakers: European Commission (eg. DG Research, DG TREN), European Technology Platforms (ERRAC, ERTRAC, EIRAG, WATERBORNE), European Associations (CLEPA, EARPA, EMEC, COREDES, UNIFE, UIC, ELA), major R&D players (University of Strathclyde, TNO, Fraunhofer, CTO,...).

Contacts:

Mr Jean-Paul Borleteau, SIREHNA, [sirehna@sirehna.com](mailto:sirehna@sirehna.com) (+33 2 51 86 02 93)

Mrs Annick SCOTT, SIREHNA, [sirehna@sirehna.com](mailto:sirehna@sirehna.com) (+33 2 51 86 02 86)

*This event is organised in the framework of the European Project 'EUROTRANS-days' funded by DG Research (thematic priority Surface Transport, 6<sup>th</sup> Frame Work Programme)*

*Partners of EURO-TRANS\_Days include: OSEO (F), SIREHNA(F), IFTR (PL), VDI/VDE (DE), BALANCE(DE), CFA (UK), SENTER NOVEM(NL), APRE(IT), ENPC (F), CIT(ES), CETRA(SK)*

- However, also due to key persons illness in SIREHNA (five weeks in January and February), the leadership of this event was then taken by CIT on 22 february, with the event scheduled on 27-28th March 2008, just before the closure of the project.
- To prepare and attend to the two days event in Madrid on 27-28 March 2008
- To animate the practical session on EoI of a 'Logistic Cluster' in preparation
- To attend individual meeting with PESI/TESA (Spain)
- To attend the debriefing meeting and final project meeting in the afternoon of the second day, with participation of Peter Crawley (DG Research)

### **2.3.3 IFTR PAS**

Support to CIT, the conference organizer in Madrid. We sent more than 2000 e-mails inviting to the conference. We had also some personal meetings e.g. with national technology platform leaders about the conference. Finally two persons from Poland participated to the conference.

As consortium partner IFTR PAS had during the conference presentations on:

- SRA of ERTRAC
- SRAs for Polish Technolgy Platforms for Road and Rail

For the conference in Madrid IFTR PAS made a deep search for SMEs. Two SMEs were registered but finally they could not come. However one SME prepared a presentation on the company and IFTR PAS presented the company at the conference.

During the conference IFTR PAS also chaired one project session as well as took part in panel on how to improve proposals.

### **2.3.4 VDI/VDE**

Promotion and Dissemination Warsaw and Madrid conference:

- Invitation sent to 85 small and medium seized Enterprises in Germany
- Invitation sent to 9 German transport associations
- Event announcement sent to 28 transport and logistic magazines in Germany
- Forwarding of information to the NCP in Switzerland (Dr. Randall) and NCP in Austria (Mr. Rohowetz)

Participation in the event and chairing of the Session "Road – Expression of Interests" on Friday

### **2.3.5 BALANCE**

BALance circulated the event announcement to selected business contacts and participated in the event and gave a presentation about the activities of the WATERBORNE technology platform.

### **2.3.6 CFA**

Participation in Madrid event, including leading discussion on Waterborne proposals. Furthermore, I participated in a round-table discussion on SME participation.

### **2.3.7 SENTER NOVEM**

SenterNovem attended the Madrid event on March 27 and 28 2008. SenterNovem gave a presentation on SME experiences from the Netherlands, took part in the plenary round table discussions and chaired the parallel session on rail-related research

### **2.3.8 APRE**

APRE (Sabrina Bozzoli) participated to the Second Euro-Trans Day International Workshop, held in Madrid from 27<sup>th</sup> to 28<sup>th</sup> March 2008; it contributed to its successful performance, carrying out the following activities:

- Round table on Improving project proposals;
- Coaching session on intermodal project proposals and expressions of interest

### **2.3.9 ENPC/RST**

### **2.3.10 CIT**

CIT (Juan B. Pérez Prat) was the coordinator and the rapporteur (see CIT Deliverable 3.1) of the second EUROTRANS Days workshop Madrid 27 and 28 March 2008

### **2.3.11 CETRA**

Realization of the Madrid event

The objective was organized the two days event in Madrid (27.3-28.3.2008)

CETRA – participated on the conference in Madrid and Doc. P. Fabian Warsaw and CETRA presented his presentation about the opportunities for SMEs to participate in the projects in 7FP

### **2.3.12 Synthesis of the results**

The workshop was organised along the 6 weeks after the announcement on February 12<sup>th</sup> of the joint SIREHNA- OSEO inability to proceed with the organisation of the workshop expected by contract in Paris, due to simultaneous sickness of the surface transport personnel. Spite of the limited time, the outline, objectives and contents of the Warsaw workshop were kept at the Madrid workshop and the workshop was attended by near 100 persons with more than 15% SMEs and the feedback of the attendants and comments received were highly positive.

### Workshop global assessment

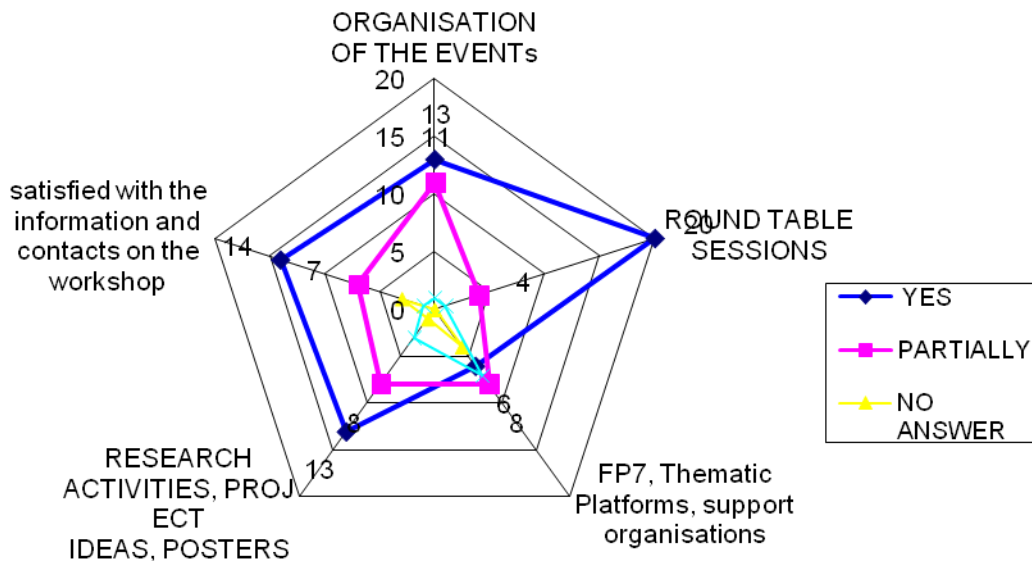

See Deliverable 3.1 for details

The balance of foreign against national attendants was very low (24% v 76%) not allowing reaching the 150 intended attendants target. To note that one third of the attendance was primarily interested on the Logistics and Intermodal sector

The main conclusions were:

- The high attendance level of Spanish organizations: on the Warsaw workshop , 34 persons (the 39% of the total attendance from outside of the organising country); more than doubled in number in the Madrid workshop with 76 attendants from Spain. The two main factors of the Spanish response were the active support of the Spanish Transport NCPs (especially Mr. Jesús Monclús and Mr Tebar Chumillas from CDTI) in publicising and promoting the event and fostering directly and indirectly newcomers and front runners participation on the EU calls, and to the intensive direct focused action by the organizer, supported by a number of national surface transport industry associations. With the exception of Romania no organisations of the new member countries (17 registered in Warsaw) come to Madrid
- On- to-one meetings were used on the Warsaw workshop by big organizations to schedule formal contacts. On the Madrid workshop CDTI offered 5 rooms for one to one or proposal consolidation meetings but with the scarce “new faces”, and with the majority of the (national ) attendants used to the informal meetings along this type of events, there was no one-to-one meeting requests in advance. However, many one to one contacts were declared on the Event Evaluation Form (60 contacts and 44 with intent of leading on to joint proposals)
- Coaching: the EUROTRANS partners offered coaching on the Madrid workshop programme releases and on the CDTI’s web special link, the coaches participating in the Round tables, sitting on the first row and introduced at the beginning of the workshop to the attendants. As most of the attendants were from Spain and the majority of them was already familiar with FP7, no coaching

was formally requested although approaches for partnership with NCPs were undertaken. Coaching 5 weeks before the Surface Call deadline (6 months on Warsaw for the 7FP Call deadline) could not be so much useful, but 8 meetings with the EC officer were instead requested

- In the Madrid workshop the parallel sessions of EoIs by transport sectors was rather successful although short of time (Friday afternoon was reserved for the EUROTRANS days final meeting, immediately after the workshop). Raising EoIs was difficult already in Warsaw, where all come from Polish Institutes (not present in Madrid) and Spanish organisations.

## 2.4 WP4

WP title	Coaching and post-event actions
WP objectives	The objective of this package is to carry out analysis of the results of the event and of the post-event questionnaire. It is also to summarise recommendations for future actions to reinforce SME networking process initiated by the event, and to provide coaching services for SMEs.

### 2.4.1 OSEO

Task 4.1 Organisation of the debriefing meeting after the international workshop in Warsaw on October 18<sup>th</sup> 2007. Preparation of Paris event.

Task 4.4

### Euro-Trans Days - One to One Meetings

#### Results

Number of persons registered for the one to one meetings	100
External profiles processed	27
Number of meetings requests	196
Number of meetings cancelled prior to the event	22
Number of meetings matched	161
Number of meetings which couldn't be matched (no common slots, ...)	6
Number of meetings which took place	101
Number of transnational meetings which took place	81
Number of persons who had meetings	64

#### Indicators

Persons who had meetings / registered for the meetings	64%
--	-----

Meetings which took place / Meetings requests	52%
Meetings transnational / meetings took place	80%
Average number of meetings per person	3,2

### Euro-Trans Days - One to One Meetings

#### Follow Up

Number of feedbacks returned	11
<b>Status Collaboration</b>	
None	30
On going	14
Reached	0
<b>Type of Collaboration</b>	
Technical	14
Commercial	3
Industrial	2
Financial	1

#### 2.4.2 SIREHNA

Contribution in tasks:

- (4-1) debriefing of the event in Warsaw
- (4-2) debriefing of the event in Madrid
- (4-3) questionnaire analysis
- (4-4) coaching services
- (4-5) recommendations for future actions

In this work package the contribution of SIREHNA was:

- To attend the two WP4 debriefing meetings organised in Warsaw and Madrid, just after the events: number of participants, organisation of the events and satisfaction of participants regarding the different session offered by the workshop, recommendations for future actions,
- To collect the short reporting of each partner after the events.
- To collect and analyse the answers of the post-event questionnaire for each post event.
- To provide a feedback report to SMEs (deliverable D4.1)
- To provide 'coaching services ' during and after the workshops (see contacts in descriptions in WP2 and WP3)
- To make a synthesis of the results of the project as well as recommendations for future actions (deliverable D4.2)

-

### **2.4.3 IFTR PAS**

Post-event actions consisted of preparing the list of all participants to the Warsaw event and supporting SIREHNA in gathering the questionnaires. Furthermore, following the Warsaw conference, coaching services were offered to participants interested in first calls for proposals for Transport. The coaching was also provided during the conference in Warsaw as well as some meetings with some people interested in second calls of Transport took place in Madrid.

### **2.4.4 VDI/VDE**

See WP2

### **2.4.5 BALANCE**

During the Warsaw event BALance discussed 6 project proposals under preparation with the project coordinators and provided advice on the completion of the consortium composition. Furthermore, BALance pointed out other activities to be considered (finished or running projects) by the project consortium.

### **2.4.6 CFA**

- Participated in coaching of SMEs, during the Warsaw event, at the request of the participants.
- During the Madrid event there was little opportunity for on—to-one coaching, however, discussion groups were set up to discuss potential proposals and an element of coaching took place during this time.

### **2.4.7 SENTER NOVEM**

The participants of both the Warsaw and Madrid event from the Netherlands were contacted. Were appropriate these participants have been further supported with their project ideas and strategy towards FP7

#### 2.4.8 APRE

Post-event actions mainly consisted in reporting the events' outcomes - both in terms of participation and success rate of the several informative/coaching sessions - and recommendations for future goings on.

APRE contributed to such analysis by providing a detailed post-event questionnaire, together with an in-depth report assessing the overall organization and implementation of the workshop.

Furthermore, following the Warsaw workshop, coaching services were offered to those participants interested in having support to participating to the first and second calls for proposals on "Transport (including aeronautics)" - Sustainable surface transport sub-theme.

Finally, the European Commission was provided with:

- a Final Activity Report [M1-15] on APRE overall contribution to the project implementation;
- a Final Management Report [M1-15] on APRE expenses and their justification with the performed activities.

#### 2.4.9 ENPC/RST

#### 2.4.10 CIT

Post-event actions consisted of

Analysing and reporting the events' outcomes - both in terms of participation and success rate of the usefulness of the contacts and lessons learned for new joint proposals and contacts.

Economic settlement of the workshop subcontractors and with CIT need several actions to obtain the Coordinator funds for the workshop expenses and for the payment of the advance for the organisation of the workshop, not yet settled at this date (6 months after the agreement for the new organisation of the workshop)

CIT asked to CDTI to maintain as long as possible the special link on the web (already in place)

See Deliverable 3.1 from CIT which includes the detailed analysis of the Madrid workshop post event questionnaire, and workshop and final conclusions.

CDTI recorded all the workshop plenary presentations in video, and the analysis with the records of the questions and answers could be of interest but the above mentioned difficulties in economic settlement discouraged CIT to undertake this review.

### 2.4.11 CETRA

Coaching and post-event actions

The objective of this package is to carry out analysis of the results of the event and of the post-event questionnaire. It is also to summarize recommendations for future actions to reinforce SME networking process initiated by the event, and to provide coaching services for SMEs.

CETRA in this work package:

- Prepared and published the brochure (guide book) for 7FP
- Collected the contacts of SMEs in Slovakia
- Made contact lists of SMEs
- Sent the invitations of the conference in Warsaw and workshop in Madrid to the SMEs in Slovakia
- Prepared and organized two workshops called : Info Day about 7FP – 1<sup>st</sup> INFO Day was organized on 4.12.2007 and 2<sup>nd</sup> INFO Day was organized on 13.3.2008. These events informed the participants about the rules of the 7FP, about the financial rules in the 7FP, about opportunities to participate in the 7FP and about new calls in the 7FP which was published by European Commission.

### 2.4.12 Synthesis of the results

This WP was dedicated to coaching and post-event actions.

The two events gave opportunities to SMEs and participants to obtain coaching services from the ETD partners. The coaching services have concerned more participants in Warsaw event, than in Madrid because the number of participants and the number project presentations/discussions were more important in the Polish event. This was carried out in different ways by each partner:

- Informal contacts and participation in ‘one to one meeting’ during the events (all partners)
- Open discussions and project ideas presentations during the events (all partners)
- Pre- and post-event contacts (CIT, IFTR, APRE, SENTER NOVEM)

After each event, the debriefing meetings pointed out that the participation of SMEs was indeed quite low (about 15%), and also the participation of Poland in Warsaw and Spain in Madrid was more than 50%. However the contacts with SMEs were very fruitful for developing ideas of proposals and providing advices to SMEs about FP7 opportunities.

ETD partners agreed that it was difficult to convince the SMEs to travel abroad for European Business events as proposed by ETD project. It was then agreed that for future actions, another way should be found. For instance, the organisation of awareness meetings at national level through the network of professional associations and local business centres seems to be a more appropriate to approach efficiently the SMEs, then the important work of ETD partners would be to provide relay and networking at European level: creating ‘market place’ of project opportunities, project ideas, SME’s competencies, .... In that way, the ETD partners should then have a well established knowledge of the projects in preparation and contacts with key stakeholders leading European projects. Therefore, the active participation of key R&D leaders is recommended, as well as industry leaders (major industries of surface transport, subcontractors of rank n°1) who will attract the interest of SMEs to attend local awareness meetings.



### 3. MANAGEMENT ACTIVITIES

#### 3.1 WP5

WP title	Management
WP objectives	The objective of the project management WP is to optimise the working conditions of the project. The project manager is also in charge of the progress control, the decision-making mechanism, smooth communication with the European Commission and within the organisation committees, but also with the outside world.

##### 3.1.1 OSEO

Task 5.1: Project administration and management, workpackage co-ordination

OSEO coordinated the work of the Technical/Scientific Committee in order to design the programme of the Warsaw event. OSEO identified the speakers and prepared the overall organisation of the Warsaw event with all partners and in particular P3. OSEO assured the day-to-day management of the project by e-mail and phone calls. OSEO provided the consortium partners with material for communication and promotion on the event (pre-announcement, programme, brochure, e-mails for relaunch of promotion). OSEO ensured the communication with the Commission for the Warsaw event, the amendment of the contract due to the change of the Paris event into the Madrid event. OSEO ensured the administrative and financial co-ordination of the project and the logistics and organisational aspects of the meetings and the plenary sessions

Task 5.2 Dissemination and exploitation

From the beginning and on the demand of the Commission OSEO made substantial efforts in order to exploit experience gained from this action and ensure a follow-up of the EURO-TRANS\_Days action. In this perspective OSEO organised several meetings and teleconferences with the EURO-TRANS consortium and the coordinators of 4 other SSAs dealing with SMEs in surface transport AUTO-IN, HUNPOLTRANS, TRANSMES, SURFACE NET. These actions resulted in the submission of the proposal STARNET in the call

CSA2 meeting held in Brussels on 15<sup>th</sup> February 2007

Meeting with the project officer of the Commission and the 4 SSA on March 26<sup>th</sup> 2007 followed by a meeting between the coordinators of the SSA and the EURO-TRANS partners in Brussels.

3 teleconferences on 13<sup>th</sup>, 20<sup>th</sup> and 26<sup>th</sup> April 2007.

##### 3.1.2 SIREHNA

In this work package the contribution of SIREHNA was:

- To provide assistance to OSEO: in the preparation of the project meetings organised in Brussels, and in the overall coherence to ensure that the targets of the project (technical contents, organisation the two events).
- To produce the final report summarising the project activities and participations of the partners, and also assessing its impact: deliverable D5-1.
- To contribute to the preparation of deliverable D5-2 summarising the dissemination and exploitation activities.

### **3.1.3 IFTR PAS**

IFTR PAS was responsible for WP2 and during the project execution coordinated all activities of the WP. IFTR PAS prepared deliverable D2.1 - report on the conference in Warsaw. Also as project partner IFTR PAS contributed to the final project reports: final activity and final management. IFTR PAS participated to the kick off meeting, the meeting regarding the SSA project cooperation organized by DG Research as well as the final project meeting.

During the final stage of the project IFTR PAS was also active in exchange of emails regarding the project amendment including the budget reallocation.

### **3.2 Contractors**

*The following changes have been agreed between the partners of the project (PROJECT AMENDMENT), reported in the next page.*

Maisons-Alfort, 8<sup>th</sup> September 2008

Mr. Adam Grodzicki  
Commission of the European Communities  
Research Directorate General  
RTD/H.02  
B-1049 BRUSSELS - BELGIUM

Dear Adam Grodzowski,

**Subject: Revised request for Amendment to Contract No. 044599  
Project "EURO-TRANS\_Days"**

Further to the request for amendment of March 4 2008, and the reserve of analysis raised by the Commission please find herewith on behalf of the consortium following changes in the budget redistribution. Further to the request of the Commission audit cost made by the partners and not taken into account in the DOW were redistributed to a maximum of 600 €

**P1 OSEO**

An additional cost of 1263,16 € will be subtracted from OSEO initial budget in order to cover the cost of final meeting organised in Madrid (the amount has already been transferred to P10)

**P2 SIREHNA**

Following the remark of the Commission considering the budget of Sirehna disproportionately large but taking into account that Sirehna prepared the Paris event until 3 weeks before the portential date, the increase of 12.348,00 € as was stipulated in the request of March 4 has been reduced to 8.596,48 €

**P3 IPPT**

300 € request for audit cost were added to the initial budget

**P4 VDI-VDE**

VDI-VDE took in charge the pre-arranged meeting service during the Warsaw-event. The cost of 1900 € (for the tool and the travel and subsistance costs of 2 persons) could not be taken on the budget of P3 and will be redistributed to VDI-VDE from general budget

**P5 Balance**

600 € were added to the initial budget for Audit cost

**P6 CFA**

600 € were added to the initial budget for Audit cost

**P7 Senter Novem**

No change

**P8 APRE**

600 € were added to the initial budget for Audit cost

**P9 ENCP/RST**

P9 withdrew from the consortium and will reimburse the amount of 5.421,60 € received as a first payment for the contract to the coordinator

**P10 CIT**

To the increase of 1,25 pm for organizing the second workshop in Madrid 11.850 were added 1504,20 specific cost, 1263,16 € for the organisation of the final meeting in Madrid, 600€ Audit cost.

**P11 Uniza/Cetra**

no change

Further to the first request of amendment the amount for WP3 and of specific cost should be transferred by P9 to P10. Finally these amounts were reimbursed by P9 to the coordinator who made the necessary transfers to P 10.

Partner 1 OSEO. The cooperation with Edith Petitet came to an end on July 22<sup>nd</sup> and Ineke Petit is again in charge of the management tasks.

***Change of contractors details***

Since the first request of amendment the following contractors' details are changed as follows :

- The Partner number 1 *OSEO Innovation established in 27-31, avenue du Général Leclerc, 94710 Maisons-Alfort Cedex - France*, is now represented by Laure REINHART, *Directeur Général Délégué* who replaced Jean Michel DALLE and/or Annie GEAY, *Director of Innovation*.

Following the above mentioned changes the revised budget redistribution after the end of the project is presented on the following table.

			Initial Budget	Budget according to the first request for amendment currently analysed by the EC	Final costs (according to Form-C, including audit certificate cost)	Budget for agreement on July 21 (basis for revised amendment)	Difference between Final costs and revised budget	For information : Difference between Final costs and initial budget
P1	Oséo	France	38 860,00	20 400,00	46 899,15	19 146,11	-27 753,04	-8 039,15
P2	Sirehna	France	33 132,00	45 480,00	45 086,00	41 728,48	-3 357,52	-11 954,00
P3	IPPT	Poland	27 846,00	27 846,00	28 313,53	28 146,00	-167,53	-467,53
P4	VDI-VDE	Germany	10 895,00	10 895,00	12 831,60	12 831,60	0,00	-1 936,60
P5	Balance	Germany	11 050,00	11 050,00	13 292,42	11 650,00	-1 642,42	-2 242,42
P6	Cliff Funnel	UK	13 170,00	13 170,00	14 332,00	13 770,00	-562,00	-1 162,00
P7	SenterNovem (EGL)	NL	9 840,00	9 840,00	9 333,92	9 333,92	0,00	506,08
P8	APRE	Italy	9 150,00	9 150,00	10 045,14	9 750,00	-295,14	-895,14
P9	RST	France	7 530,00	0,00	0,00	0,00	0,00	7 530,00
P10	CIT	Spain	10 877,00	24 231,00	26 084,89	26 084,89	0,00	-15 217,16
P11	Uniza/Cetra	Slovakia	7 650,00	7 650,00	7 559,00	7 559,00	0,00	91,00
	<b>SUM</b>		<b>180 000,00</b>	<b>179 712,00</b>	<b>213 777,65</b>	<b>180 000,00</b>	<b>-33 777,65</b>	<b>-33 777,65</b>

Yours sincerely,

Annie GEAY  
 Director of Innovation  
 OSEO Innovation  
 27-31 Avenue du Général Leclerc  
 94710 Maisons-Alfort Cédex  
 France

Maisons-Alfort, 4<sup>th</sup> March 2008

Mrs Susana Martins  
 Commission of the European Communities  
 Research Directorate General  
 RTD/H.02  
 B-1049 BRUSSELS - BELGIUM

## REGISTERED WITH ACKNOWLEDGEMENT OF RECEIPT

Dear Susana Martins,

**Subject: Request for Amendment to Contract No. 044599  
 Project "EURO-TRANS\_Days"**

With reference to the above noted contract, I request on behalf of the consortium to modify the contract as follows:

### *Termination of a contractor's participation*

The participation of the following Contractor is terminated from the date specified in the following table :

Contractor's full name	[End date of participation]8
Ecole Nationale des ponts et Chaussées / Réseau scientifique et technique	13 <sup>th</sup> February 2008

Article 1.2 of the contract is modified accordingly.

### *Transfer of contractual rights and obligations*

The attribution of some tasks, and therefore responsibilities and financial resources are modified as follows :

- The OSEO leadership of the WP3 and the resources initially allocated to OSEO for the implementation of the WP3 will be transferred to the Partner 2 (Sirehna) for starting the implementation and the Partner 10 (CIT), for finalising of the implementation.  
 The amount to be transferred is 18 460 €.  
 18 460 € being equal to (0.7 man.months \* 7 800 €) +13 000 € for specific costs.
- The WP3, mainly the Conference, will be held in Spain (Madrid) on March 27 & 28 without jeopardizing the building of the next partnerships as it was announced it in January.
- Partner 9 (ENPC/RST) withdraws from the consortium (13/02/08) and leaves the budget left (7 242 €) to the consortium.
- Partner 2 (Sirehna) starts the WP3 (invitation of the SMEs). Partner 1 (OSEO) transfers 12 348€ (equal to 1.26 man.months \* 9800 €) to Partner 2 (Sirehna) for this activity.
- Partner 10 (CIT) with the help of the CDTI (spanish NCP Transport) takes in charge the rest of the WP3 activities and management. The supplementary resources needed by

Partner 10 are 1.25 man.months, so  $1.25 \times 9\,480 \text{ €} = 11\,850 \text{ €}$ . Partner 1 (OSEO) transfers 6 112 € to Partner 10 (CIT) and Partner 9 (ENPC/RST) transfers 5 738 € to Partner 10 (CIT).

- The remaining budget from Partner 9 (ENPC/RST), 1504 €, is transferred to Partner 10 (CIT) for specific costs.

- Partner 1 (OSEO) keeps the coordination. A new person, Edith Petitet, will be added to the existing team. Edith Petitet or a representative of her will replace Ineke PETIT for the management tasks until the end of the contract.

### ***Modification of Annex I***

Annex I - Description of work is modified.

The revised Annex I [10 March 2008] attached to this letter replaces any former version.

A copy of the CPF A3.1 included in Annex I is attached to this letter.

### ***Change of contractors details***

I inform you that the following contractors' details are changed as follows :

- The Partner number 1 *OSEO Anvar established in 27-31, avenue du Général Leclerc, 94710 Maisons-Alfort Cedex - France, represented by Michel GUILBAUD, Directeur Général Délégué*, is now *OSEO innovation SA established in 27-31, avenue du Général Leclerc, 94710 Maisons-Alfort Cedex - France, represented by Jean-Michel DALLE, Directeur Général Délégué and/or Annie Geay, Director of Innovation*.

All other provisions of the contract and its annexes remain unchanged.

Yours sincerely,

Annie GEAY  
Director of Innovation  
OSEO Innovation  
27-31 Avenue du Général Leclerc  
94710 Maisons-Alfort Cédex  
France

## ANNEX: PLAN FOR USING AND DISSEMINATING THE KNOWLEDGE

### Section 1 - Exploitable knowledge and its Use

The objective of this section is to give an overview of the exploitable results produced by the EUROTRANS-DAYS project, and of their intended use. The identified exploited results are listed in the table below, and they are available on the website <http://www.euro-trans.info/>.

#### Overview table

table Knowledge description)	Exploitable product(s) or measure(s)	Sector(s) of application	Timetable for commercial use	Patents or other IPR protection	Owner & Other Partner(s) involved
<i>List of participants of Warsaw event</i>	<i>report</i>	<i>Surface Transport community</i>	<i>immediately</i>	<i>No patent</i>	
<i>Power Point Presentations of Warsaw event</i>	<i>presentations</i>	<i>Surface Transport community</i>	<i>immediately</i>	<i>No patent</i>	
<i>List of participants of Madrid event</i>	<i>report</i>	<i>Surface Transport community</i>	<i>immediately</i>	<i>No patent</i>	
<i>Power Point Presentations of Madrid event</i>	<i>presentations</i>	<i>Surface Transport community</i>	<i>immediately</i>	<i>No patent</i>	

## Section 2 - Dissemination of knowledge

In this section are presented the dissemination activities of the project in the form of a chart description.

### Overview table

<b>Planned /actual Dates</b>	<b>Type</b>	<b>Type of audience</b>	<b>Countries addressed</b>	<b>Size of audience</b>	<b>Partner responsible /involved</b>
<i>May to October 2007</i>	<i>Announcement of Warsaw event (e-mailing and websites)</i>	<i>Surface Transport community</i>	<i>Global</i>	<i>Global</i>	<i>All Partners</i>
<i>October 2007</i>	<i>Presentations and list of participants of Warsaw event (ETD website)</i>	<i>Surface Transport community</i>	<i>Global</i>	<i>Global</i>	<i>IFTR and BALANCE</i>
<i>January to March 2008</i>	<i>Announcement of Warsaw event (e-mailing and websites)</i>	<i>Surface Transport community</i>	<i>Global</i>	<i>Global</i>	<i>All Partners</i>
<i>April 2007</i>	<i>Presentations and list of participants of Warsaw event (ETD website)</i>	<i>Surface Transport community</i>	<i>Global</i>	<i>Global</i>	<i>CIT an BALANCE</i>